

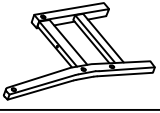

ASSEMBLY INSTRUCTIONS

PARTS LIST				HARDWARE LIST		
NO	DESCRIPTION		QTY	NO	DESCRIPTION	QTY
1	Side leg (L)		1	A	ALLEN WRENCH	1
2	Side leg (R)		1	B	JCBC SCREW 1/4"xØ13x50mm	12
3	Back rest		1			
4	Front cross bar for seat		1			
5	Back cross bar for seat		1	Please note: the part# 4/used for the front bar under the seat is shorter than part#5/used for the back bar under the seat.		
6	Cross bar		1			
7	Chair seat		1			

Step 1: Align the left leg frame (1) and the right leg frame (2) to back rest (3) front cross bar for seat (4) back cross bar for seat (5) and cross bar (6) as shown

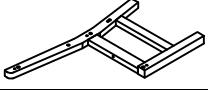

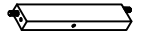
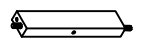
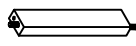
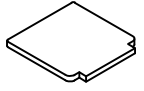
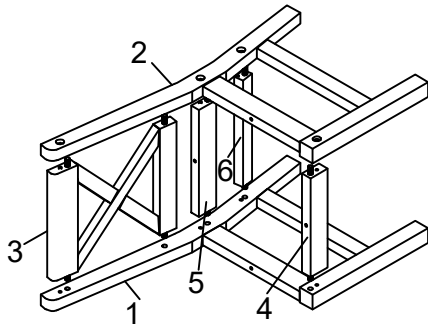
Please note: The part # 4 is shorter than the part # 5

Step 2: Insert JCBC screw (B) into each hole on left leg frame and right leg frame use allen wrench (A) to tighten JCBC screw (B) as shown.

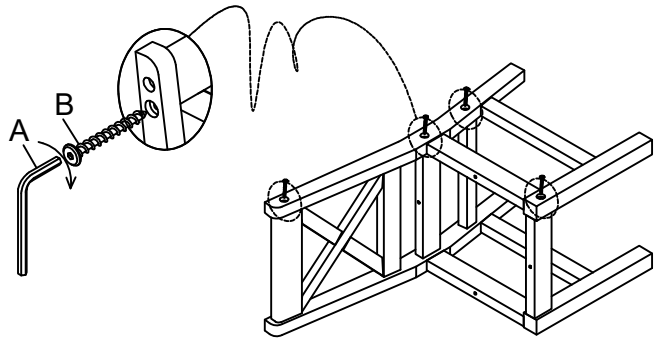

Step 3: Place the seat (7) on a flat table top protected with soft cloth or cardboard. Turn and attach assembled unit from step 2 to the seat (7) by using JCBC screw (B) and tighten with allen wrench (A) as shown.

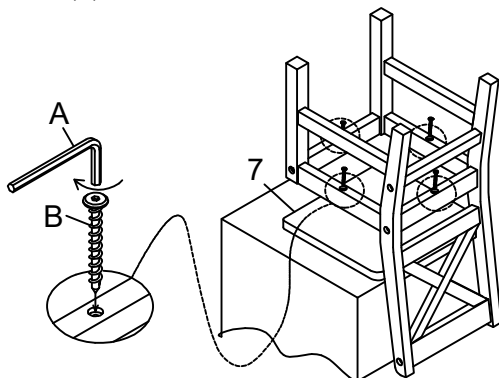

Step 4: The chair is ready to use

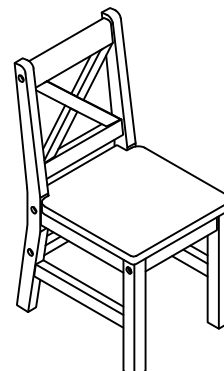

ASSEMBLY INSTRUCTIONS

IMPORTANT NOTE

***PLACE ALL WOODEN PARTS ON A CLEAN AND SMOOTH SURFACE SUCH AS A RUG OR CARPET TO AVOID SCRATCHING THE PARTS

***KINDLY FOLLOW THE ASSEMBLY INSTRUCTION STEP BY STEP.

***WE RECOMMEND THAT YOU SAVE THE ALLEN WRENCH (PART A) AND PERIODICALLY TIGHTEN ALL BOLTS/SCREWS. PLEASE

MAKE SURE ALL BOLTS/SCREWS ARE PLACED IN THEIR PROPER POSTTION AND ARE TIGHTENED SECURELY TO ENSURE YOUR SAFETY

***DO NOT STAND OR CLIMB ON THE CHAIR.

***WEIGHT RESTRICTION: 100LBS.

***NOT FOR COMMERCIAL USE.

*In case you need any extra parts, please feel free to contact us directly instead of returning your order, we will be more than happy to help you within a business day.

Version: June 17, 2024