

Installation & Assembly

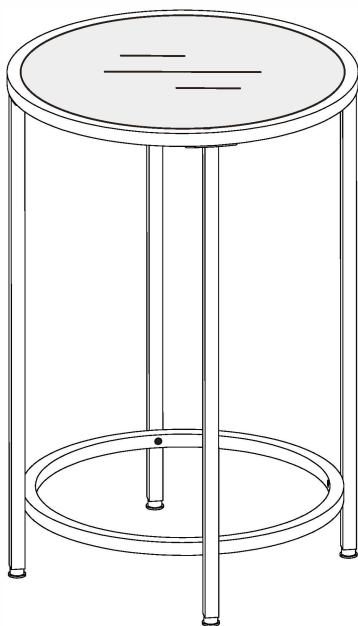

- EN** - Please read this instruction manual carefully before attempting to install.
- DE** - Bitte lesen Sie diese Bedienungsanleitung vor der Montage gründlich durch.
- ES** - Por favor lea con atención el manual de instrucciones antes de llevar a cabo el ensamble.
- FR** - Lisez attentivement cette notice avant de commencer le montage.
- IT** - Si prega di consultare il libretto delle istruzioni prima del montaggio.

IMPORTANT/WICHTIG/ATENCIÓN

IMPORTANT/IMPORTANTE



EN - We recommend **1** or more people to install.
DE - Wir empfehlen, dass die Montage von **1** oder mehreren Personen durchgeführt werden sollte.
ES - Recomendamos realizar el ensamble con **1** o más personas.
FR - Il est recommandé d'effectuer le montage à **1** personne(s) ou plus.
IT - È necessaria la presenza di **1** o più persone per il montaggio di questo prodotto.



EN - The expected assembly time is **1 h**.
DE - Die Montagezeit beträgt durchschnittlich **1 h**.
ES - El tiempo aproximado de ensamble es de **1 h**.
FR - Le temps nécessaire est estimé à **1 h**.
IT - Il tempo previsto per il corretto assemblaggio è di **1 h**.



EN - Not intended for use by children.
DE - Nicht geeignet für Kinder.
ES - Producto no apto para niños.
FR - Produit non destiné à être utilisé par des enfants.
IT - Questo prodotto non è destinato all'uso da parte dei bambini.









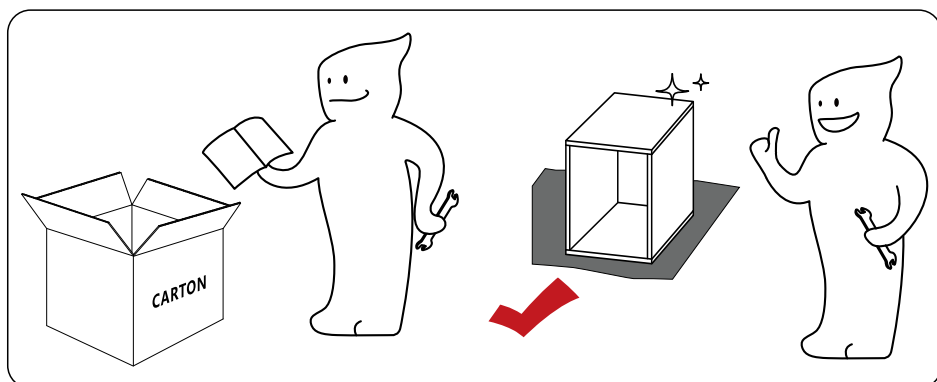
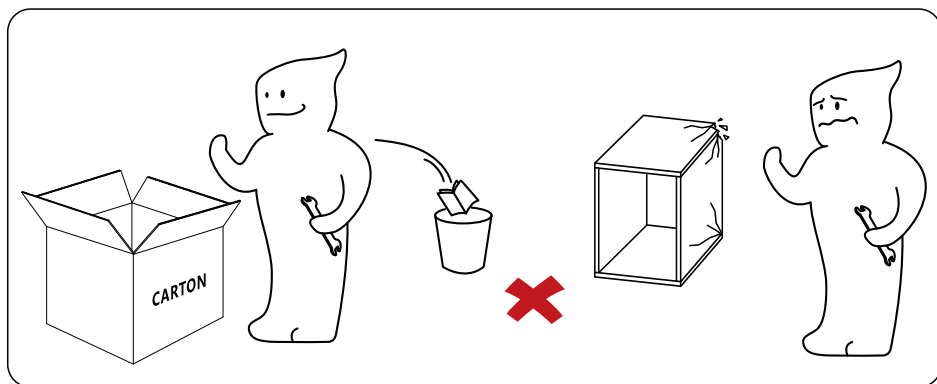

EN - Keep away from fire or other heat sources.
DE - Bitte von Feuer und Hitzequellen fernhalten.
ES - Manténgase alejado de las llamas y otras fuentes de calor.
FR - Tenir à distance des flammes et autres sources de chaleur.
IT - Tenere lontano dal fuoco o da altre fonti di calore.

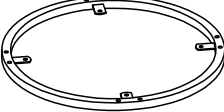
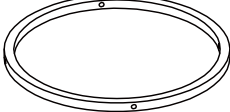

EN - We recommend wearing protective gloves.
DE - Wir empfehlen das Tragen von Schutzhandschuhen.
ES - Recomendamos el uso de guantes de seguridad.
FR - Il est recommandé de porter des gants de protection.
IT - Per il processo di assemblaggio, consigliamo fortemente l'utilizzo di guanti protettivi.



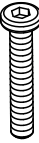

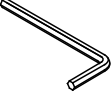
- EN** - Please follow the instruction manuals and use a pad to avoid damage during assembly.
- DE** - Bitte folgen Sie der Anleitung und verwenden Sie eine Unterlage, um Beschädigungen bei der Montage zu vermeiden.
- ES** - Por favor, siga las instrucciones del manual y utilice una cubierta o lona para proteger el producto y el suelo durante la instalación.
- FR** - Suivez les instructions de la notice et utilisez une couverture ou une bâche pour protéger le produit et les sols pendant le montage.
- IT** - Si prega di consultare il manuale illustrativo durante il montaggio e di utilizzare un cuscinetto per evitare possibili danni.

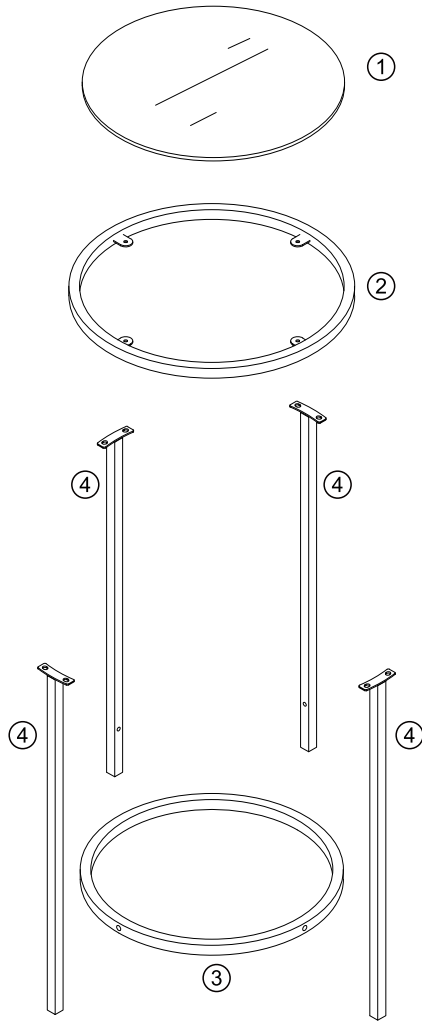

<p>① × 1</p> 	<p>② × 1</p> 	<p>③ × 1</p> 
<p>④ × 4</p> 	<p>Ⓐ × 4</p> 	<p>Ⓑ × 8</p> 
<p>Ⓒ × 4</p> 	<p>Ⓓ × 4</p> 	<p>Ⓔ × 1</p> 



1

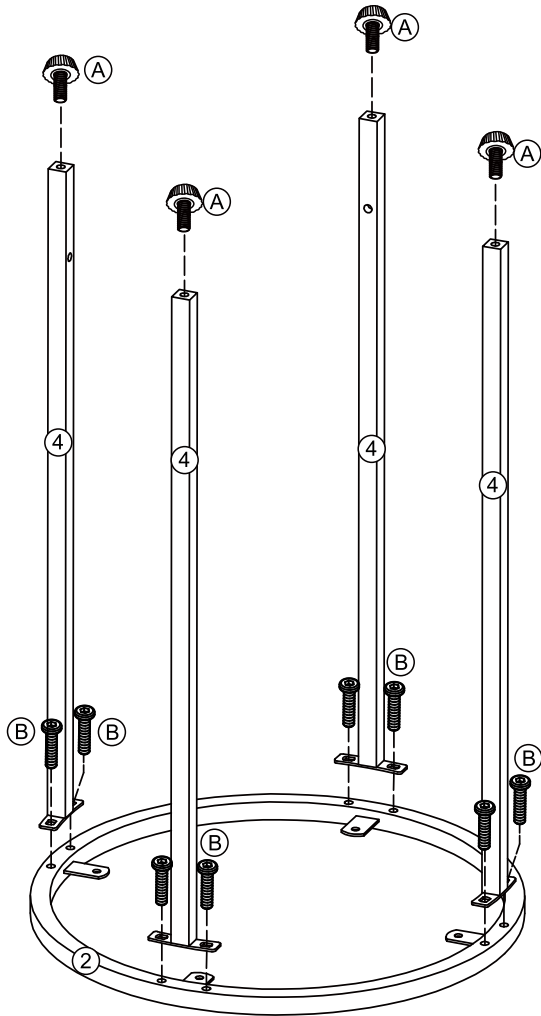

②		X1
④		X4
Ⓐ		X4
Ⓑ		X8

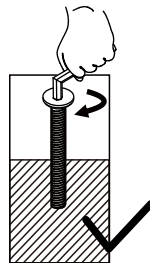

EN - Half tighten the screw
DE - Bitte die Schraube nur halb festziehen
ES - Apretar el tornillo a la mitad
FR - Ne serrez la vis que jusqu'à la moitié
IT - Stringere la vite a metà



2

③		x1
Ⓒ		x4

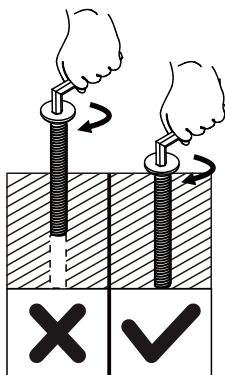
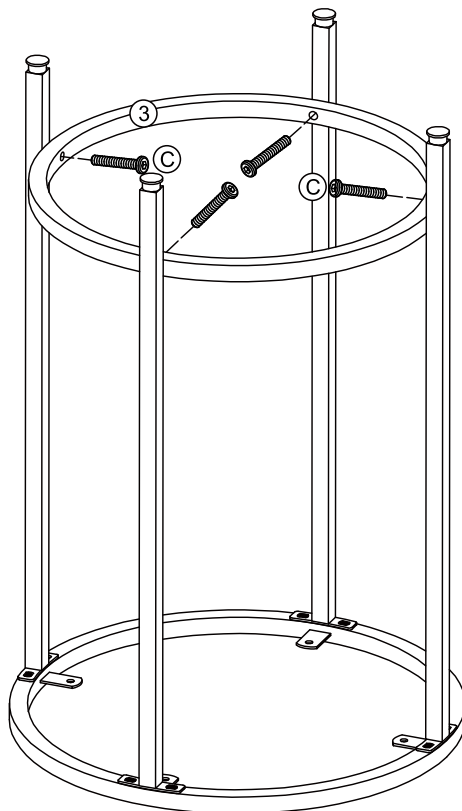

EN - Note: Tighten all screws completely after assembly.

DE - Hinweis: Ziehen Sie nach der Montage alle Schrauben vollständig an.

ES - Nota: Apretar completamente todos los tornillos después de montar.

FR - NB : Serrez les vis complètement après l'assemblage.

IT - Nota: Stringere completamente tutte le viti solo dopo l'assemblaggio.

3

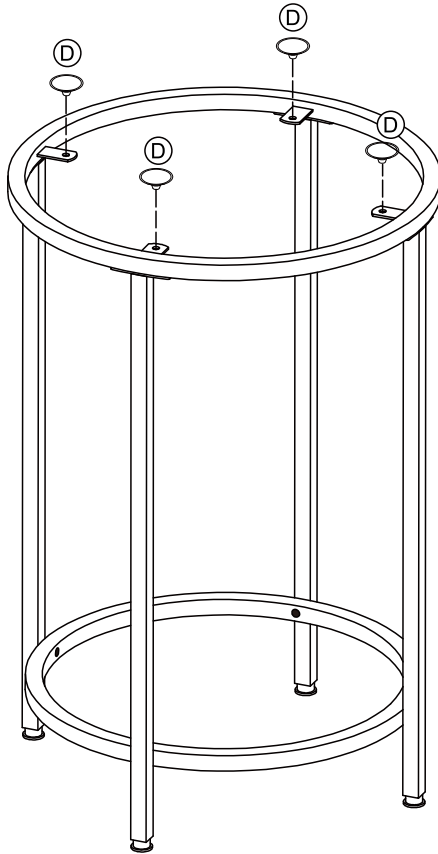

4

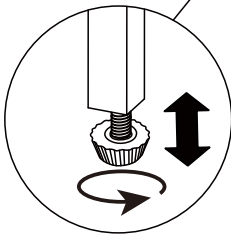
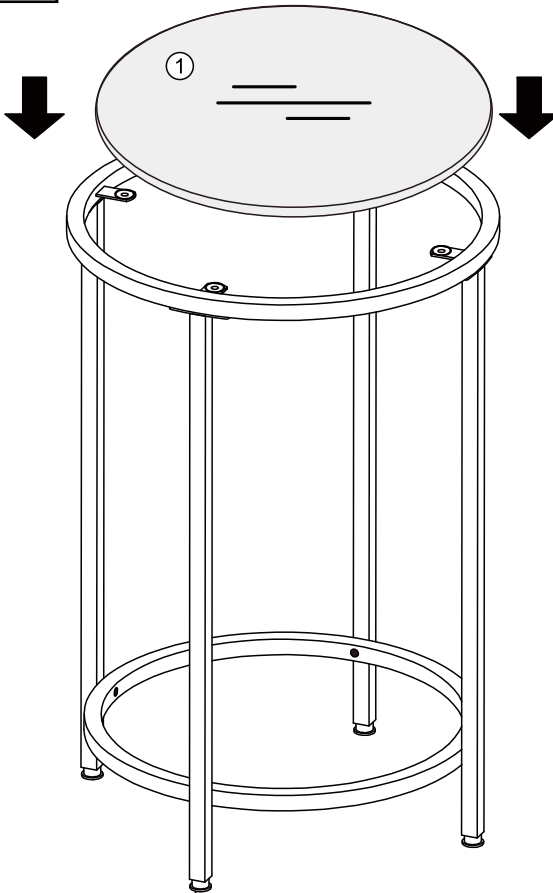

EN - Note: Screw in the adjustable feet to keep the table balanced.

DE - Schrauben Sie die Stellfüße ein und justieren Sie Diese so lange, bis der Tisch im Gleichgewicht steht.

ES - Nota: Atornille los pies ajustables a la altura correcta para asegurar la estabilidad de la tabla.

FR - NB: Vissez les pieds réglables à la bonne hauteur pour assurer la stabilité de la table.

IT - Avvitare nel piedino regolabile per mantenere il corretto bilanciamento del tavolo.