

ASSEMBLY INSTRUCTIONS

BED WITH TRUNDLE

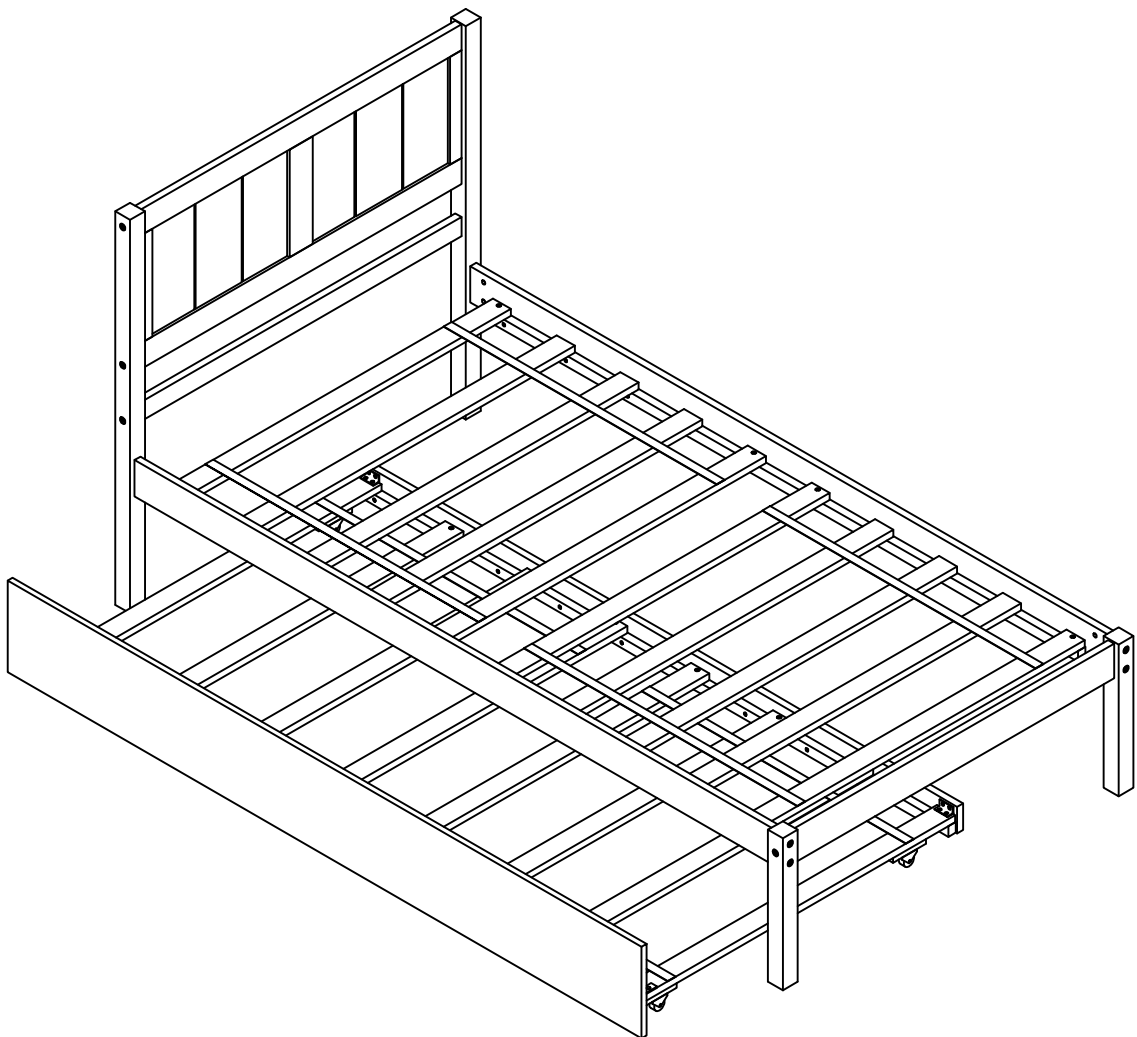





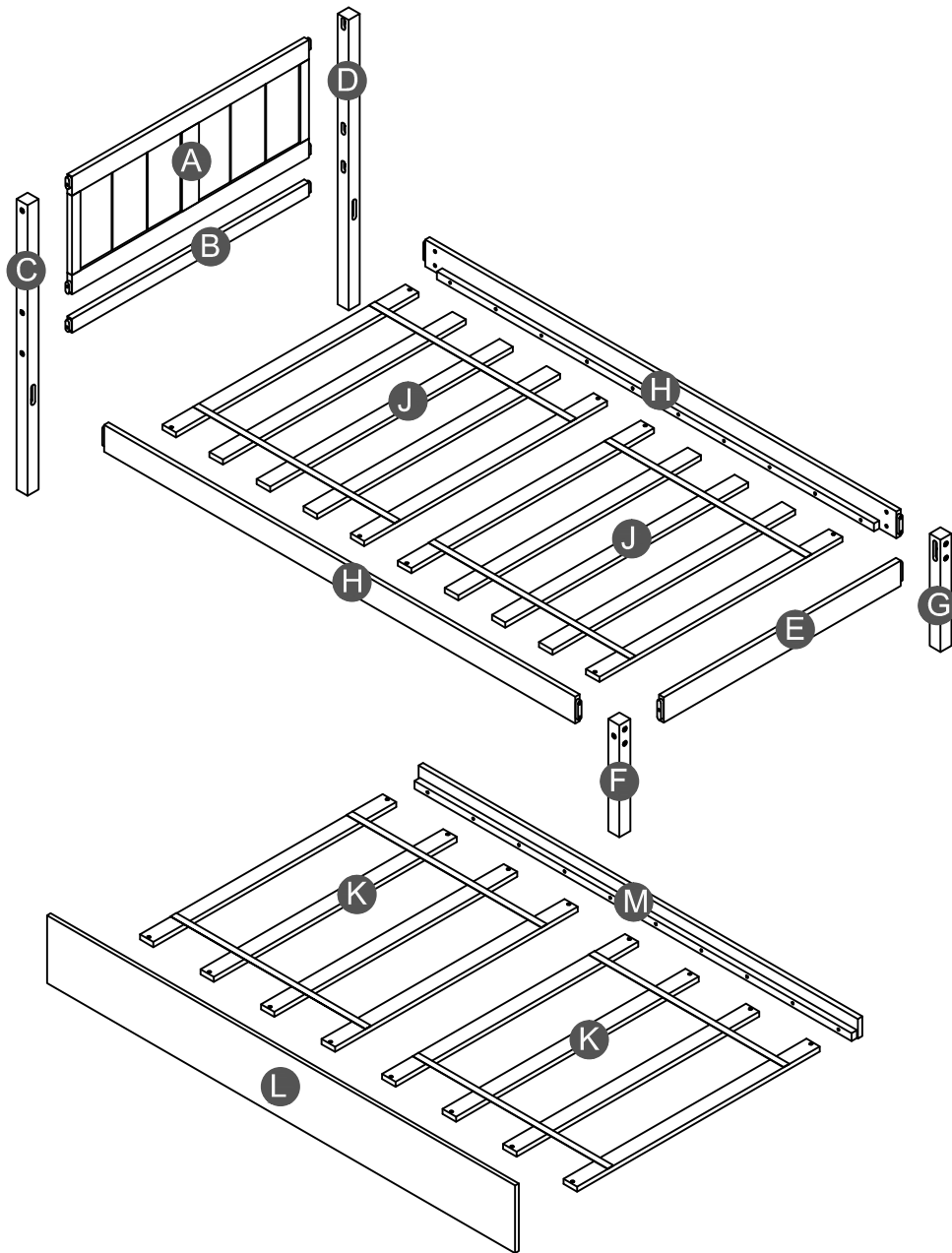

WF195108

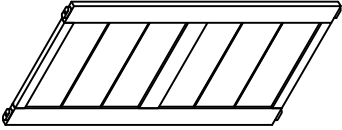
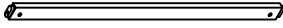
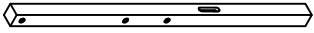

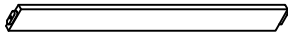
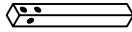
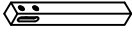

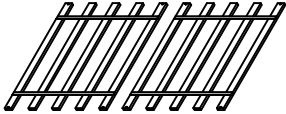
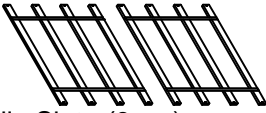

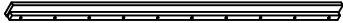
Detail View

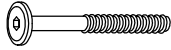
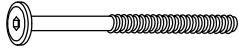

Part List

<p>A</p>  <p>Headboard - 1pc</p>	<p>B</p>  <p>Horizontal bar - 1pc</p>	<p>C</p>  <p>Leg headboard(Left) - 1pc</p>
<p>D</p>  <p>Leg headboard(Right) - 1pc</p>	<p>E</p>  <p>Footboard(FB) - 1pc</p>	<p>F</p>  <p>Leg footboard(Right) - 1pc</p>
<p>G</p>  <p>Leg footboard(Left) - 1pc</p>	<p>H</p>  <p>Side rail - 2pcs</p>	<p>J</p>  <p>Slat - (10pcs)</p>
<p>K</p>  <p>Trundle Slat - (8pcs)</p>	<p>L</p>  <p>Front panel of trundle - 1pc</p>	<p>M</p>  <p>Back panel side rail of trundle - 1pc</p>

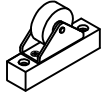
Hardware List

1  (1/4")4.5*58mm Allen key (1pc)	2  (Ø15)1/4"*80mm Hex-Head bolts (8pcs)	3  (Ø15)1/4"*100mm Hex-Head bolts (8pcs)
4  40*18*18*2mm Metal bracket (2pcs)	5  1/4"*15 (9.5mm) Horizontal-Hole bolts(16pcs)	6  Ø4*30mm Wood screws (32pcs)
7  100*63*20mm Wheels (4pcs)	8  95*95*18*3mm Metal bracket (2pcs)	9  Ø3.5*15mm Wood screws (16pcs)

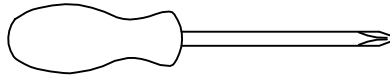

ASSEMBLY TOOLS REQUIRED (NOT INCLUDED)

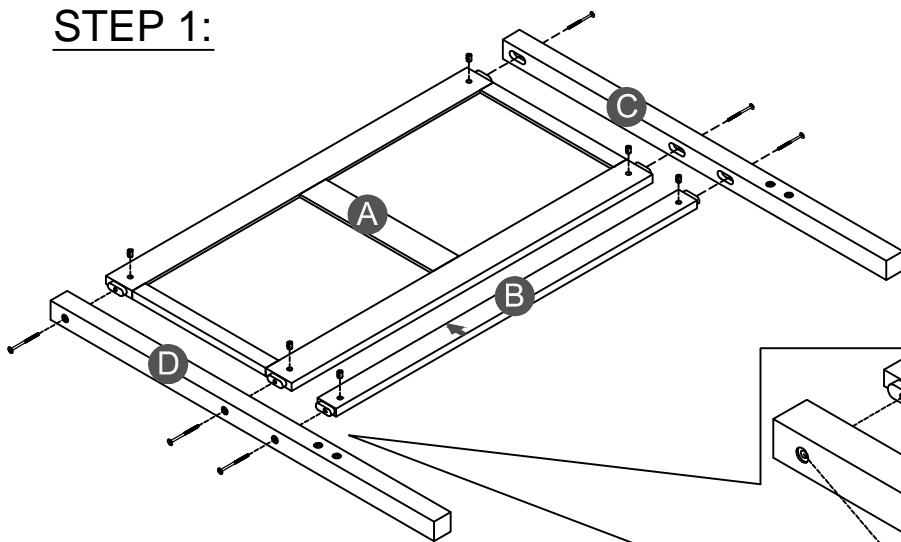

PLEASE BE CAREFUL DO NOT DAMAGE THE HOLE POSITION WHEN YOU USE POWER TOOLS !

STEP 1:



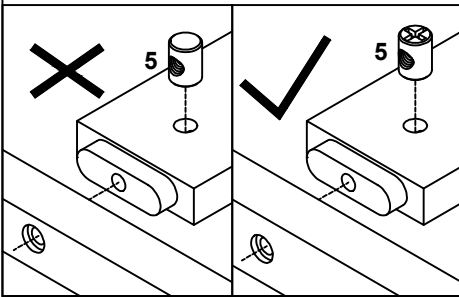
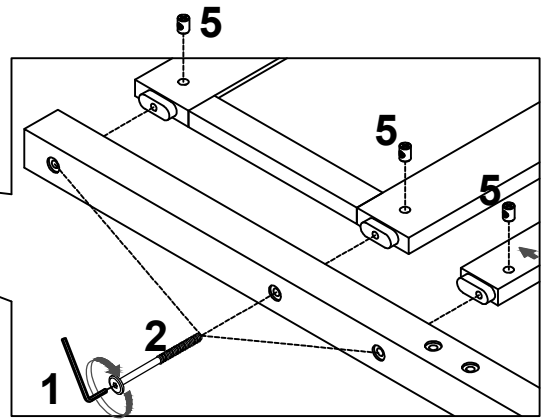

2		5	
6PCS		6PCS	

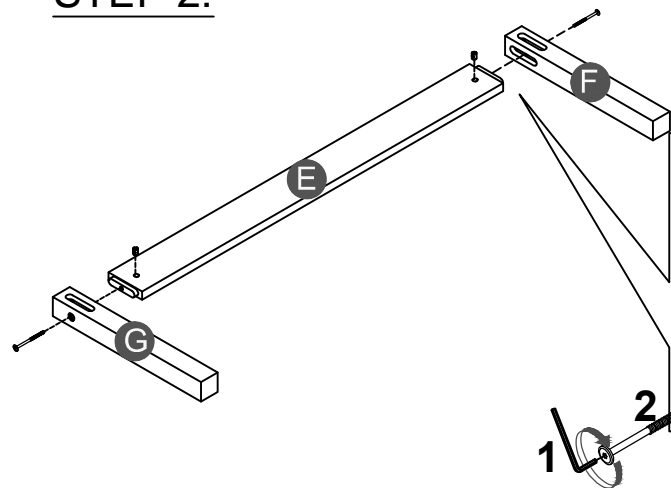

Note: Part 5 will face up with the "x" mark on it, otherwise it cannot be tightened

STEP 2:



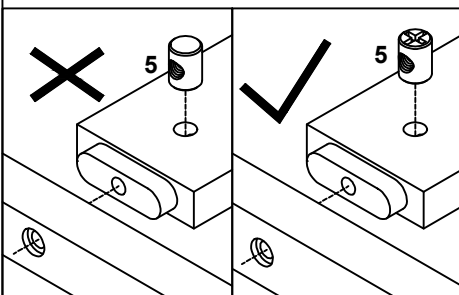
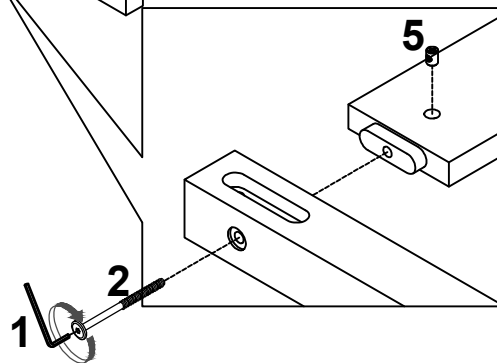

2		5	
2PCS		2PCS	

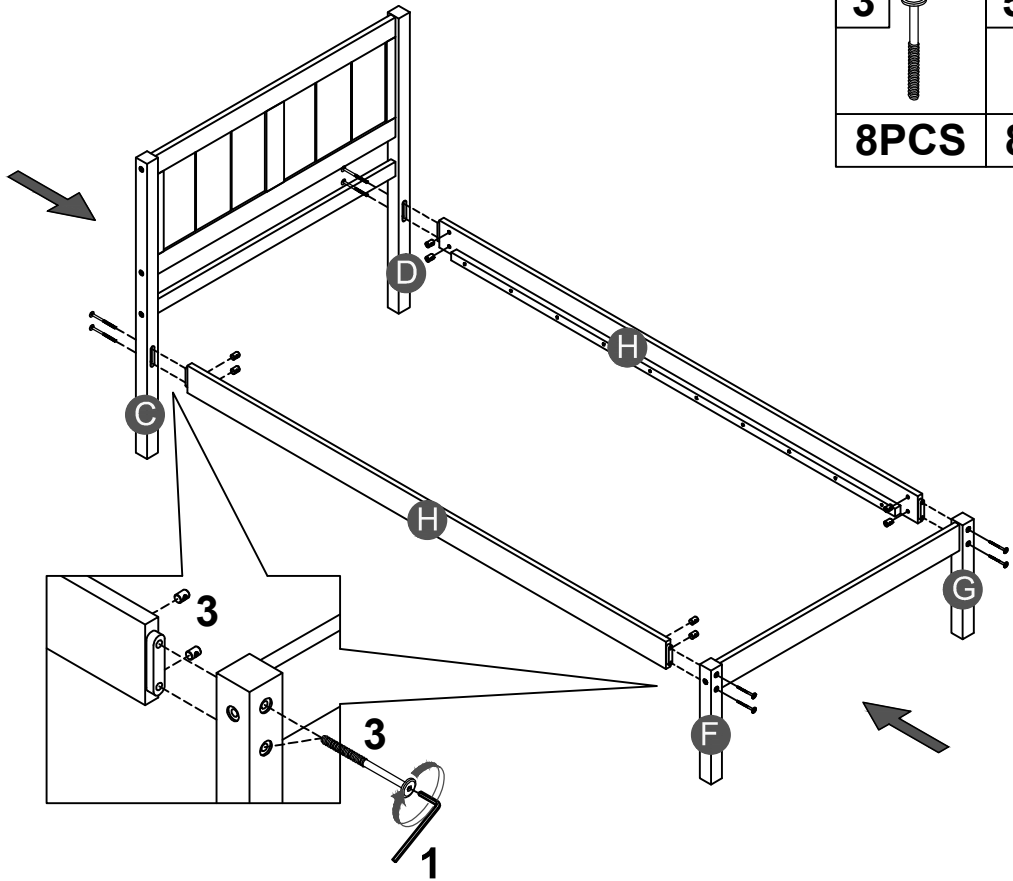

Note: Part 5 will face up with the "x" mark on it, otherwise it cannot be tightened

STEP 3:



3		5	
8PCS		8PCS	

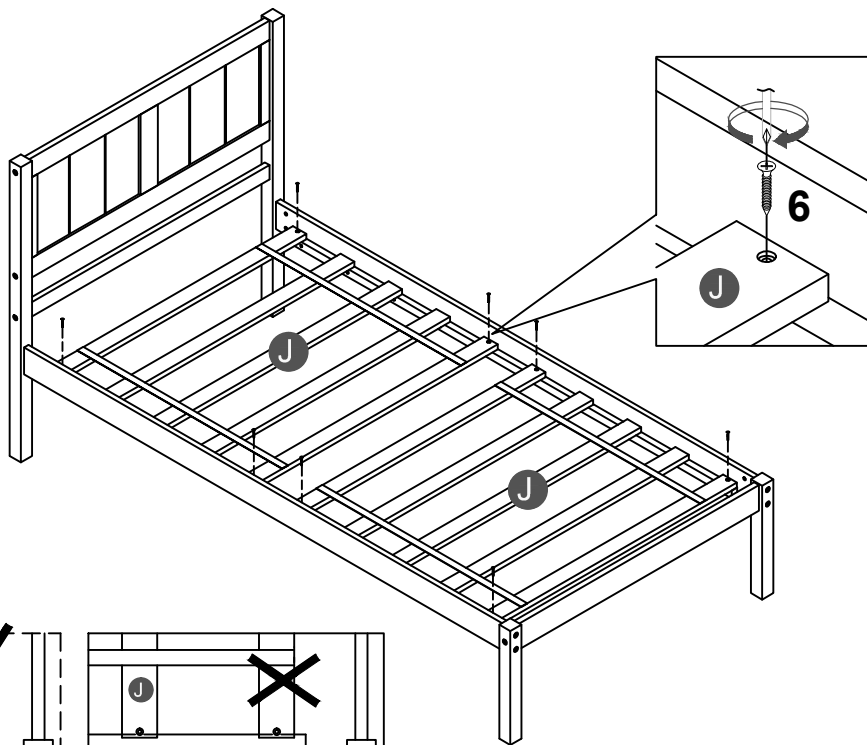

STEP 4:



6	
8PCS	

Note: Do not lock the screws of the bed slats to the outermost edge of the bed slats, you need to leave a certain space at the edges, otherwise it will cause the board to break

STEP 5:

7	6
	
4PCS	8PCS

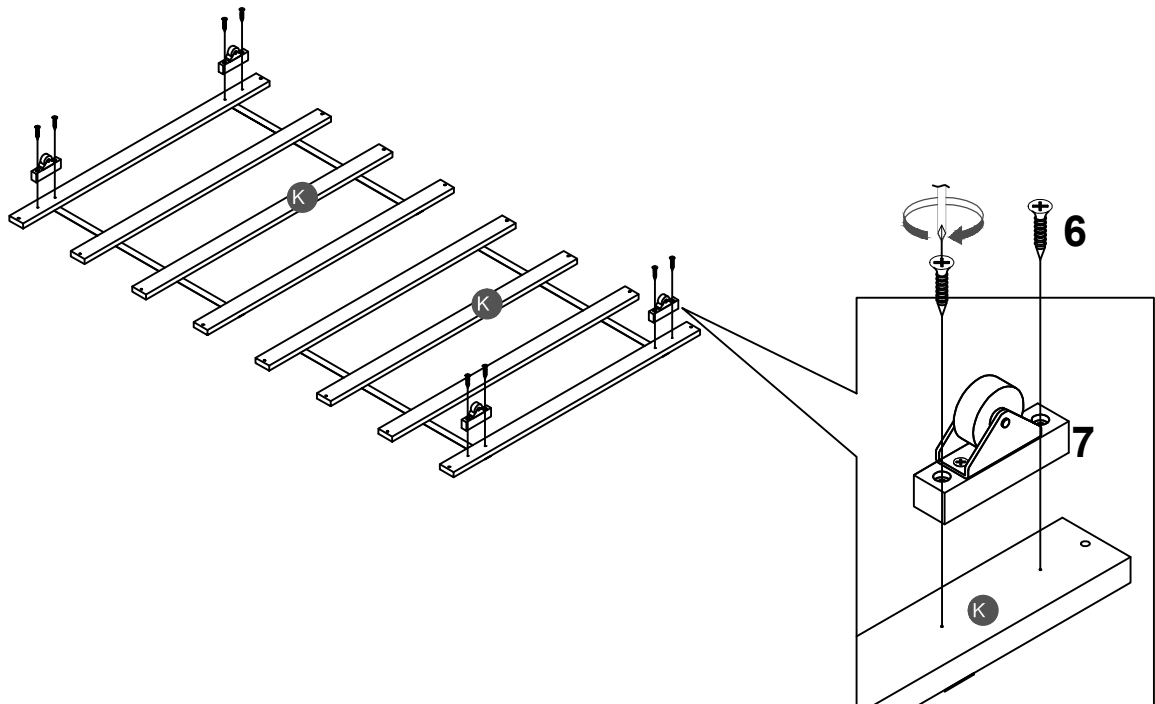

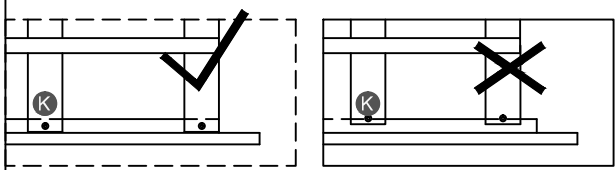
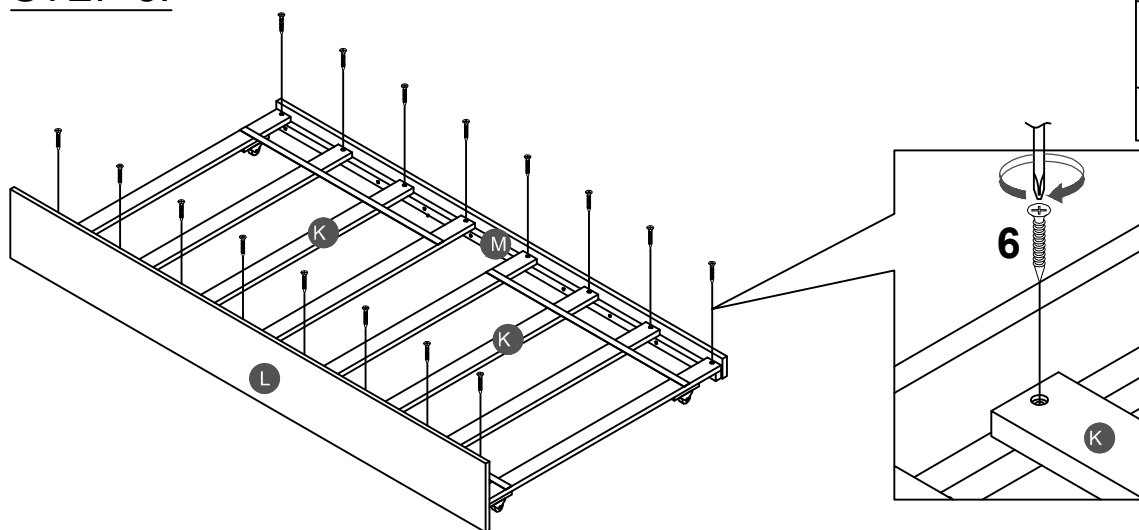

STEP 6:

6

16PCS



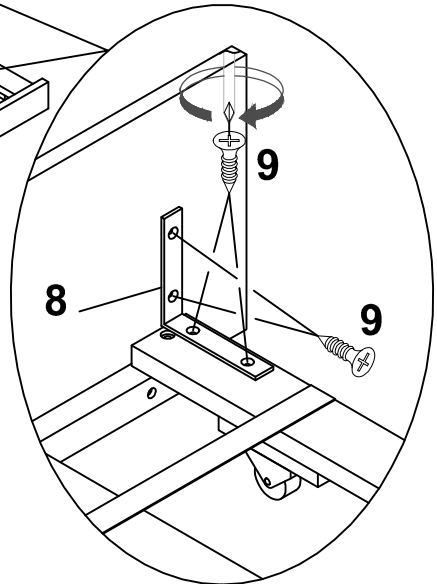
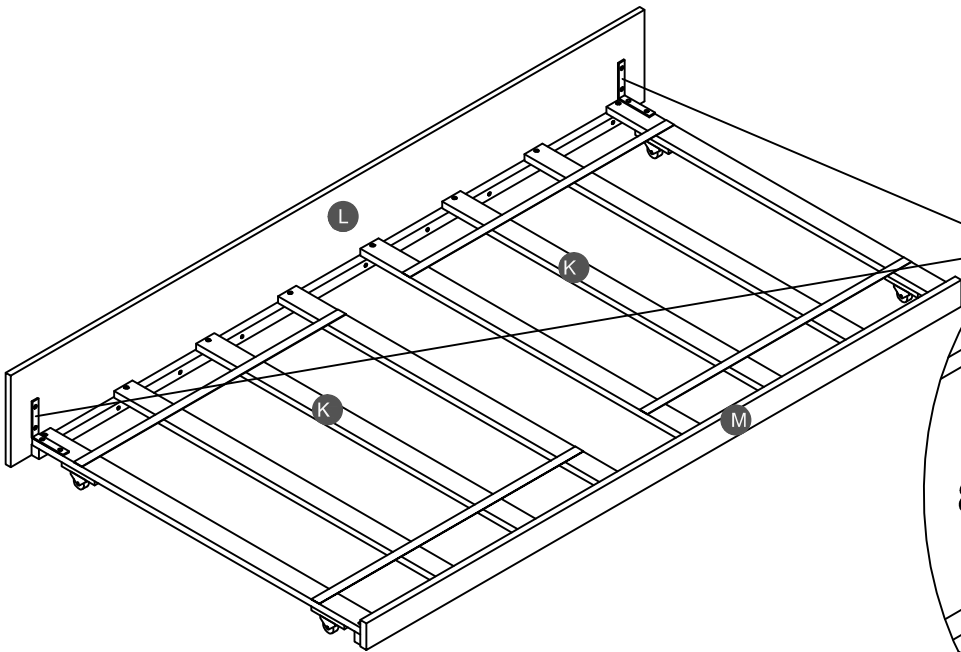

Note: Do not lock the screws of the bed slats to the outermost edge of the bed slats, you need to leave a certain space at the edges, otherwise it will cause the board to break

STEP 7:

8	9
	
2PCS	8PCS



STEP 8:

9	4
	
8PCS	2PCS

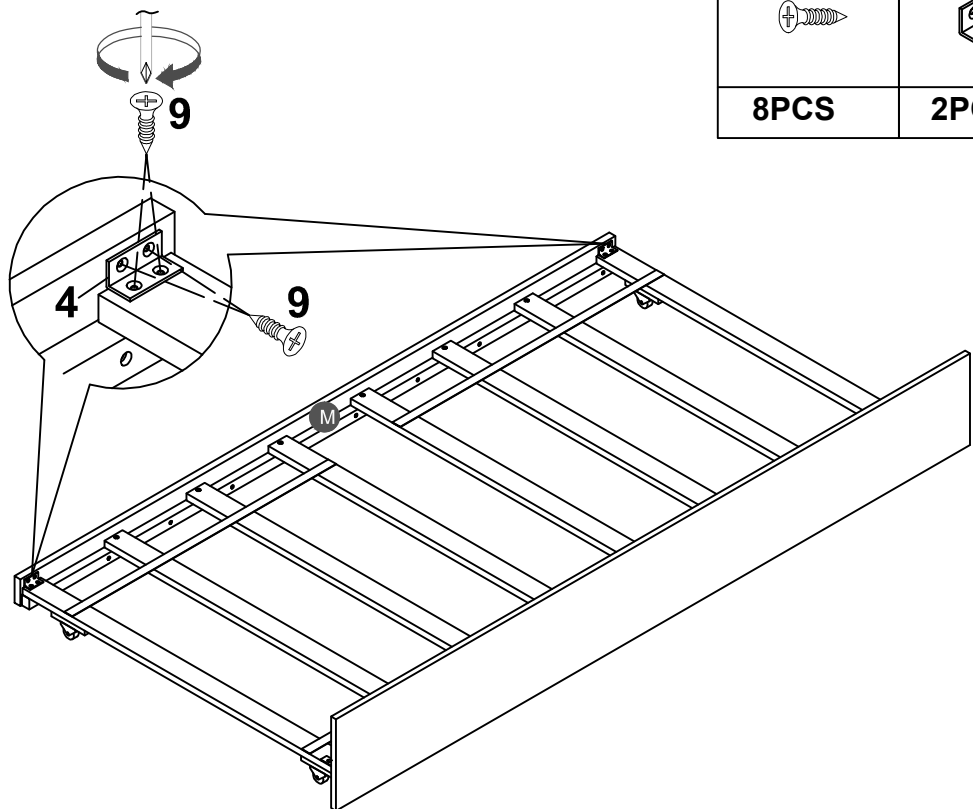

STEP 9:

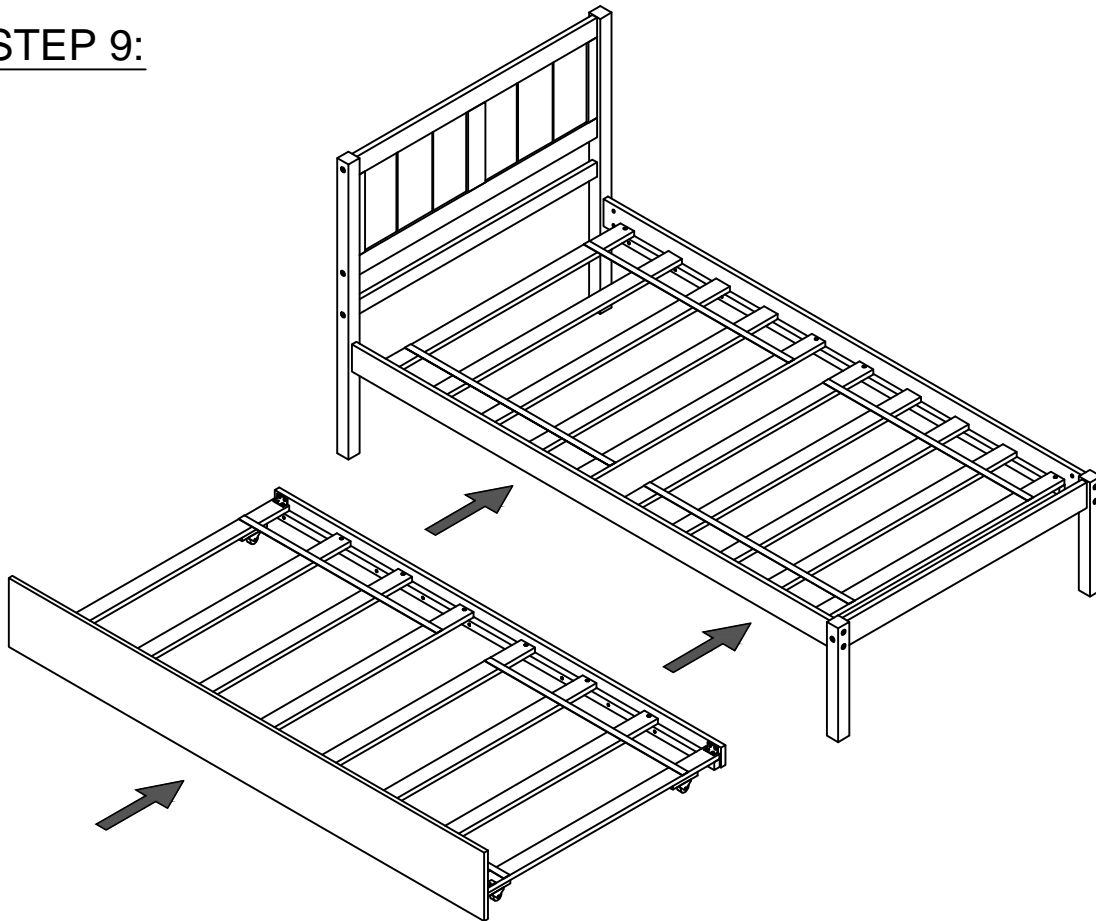

Push Trundle under the bottom of Twin Bed.

