

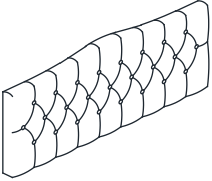

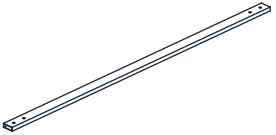

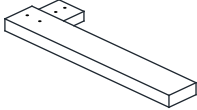

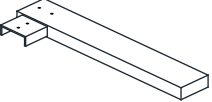
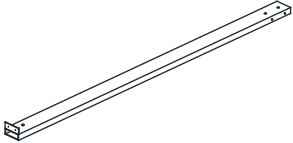
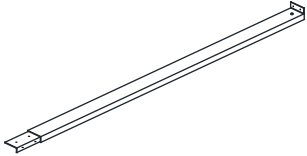
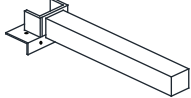
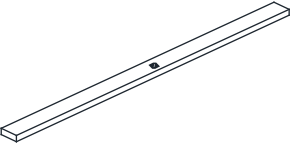

# ASSEMBLY INSTRUCTION

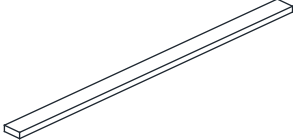
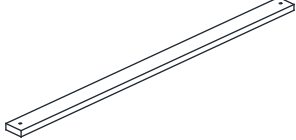

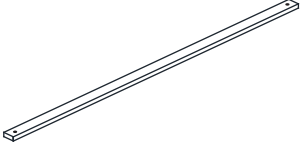
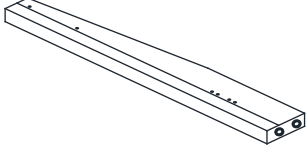
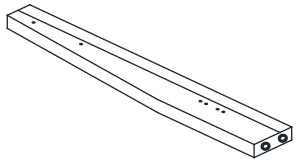
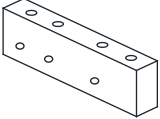
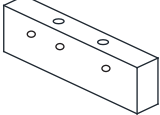





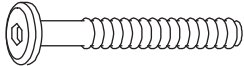

## PARTLIST

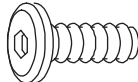
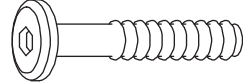
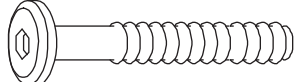
<p>1</p>  <p>HEADBOARD CUSHION x1</p>	<p>2</p>  <p>FOOTBOARD METAL TUBE x1</p>	<p>3</p>  <p>FOOTBOARD LEG (R) x1</p>	<p>4</p>  <p>FOOTBOARD LEG (L) x1</p>
<p>5</p>  <p>SIDE RAIL x2</p>	<p>6</p>  <p>SIDE RAIL x2</p>	<p>7</p>  <p>SIDE RAIL LEG x2</p>	<p>8</p>  <p>SLAT WITH NUT x4</p>
<p>9</p>  <p>SUPPORT LEG WITH HANGER BOLT x4</p>	<p>10</p>  <p>SLAT x8</p>	<p>11</p>  <p>CENTER SUPPORT x2</p>	<p>12</p>  <p>SOCKET x24</p>
<p>13</p>  <p>SUPPORT RAIL x2</p>	<p>14</p>  <p>WING (R) x1</p>	<p>15</p>  <p>WING (L) x1</p>	<p>16</p>  <p>WING SUPPORT (R) x1</p>
<p>17</p>  <p>WING SUPPORT (L) x1</p>	<p>18</p>  <p>SIDE RAIL COVER x2</p>	<p>19</p>  <p>FOOTBOARD COVER x1</p>	<p>24</p>  <p>VELCRO TAPE x1</p>

\*All parts needed are shown in above picture.  
Numbers only indicate the specific parts for easy assembly.

# ASSEMBLY INSTRUCTION

## HARDWARE

<p>A</p>  <p>JCBB SCREW M8 x 70MM</p> <p>x4</p>	<p>B</p>  <p>WOOD DOWEL M10 x 30MM</p> <p>x4</p>	<p>C</p>  <p>JCBC SCREW M6 x 15MM</p> <p>x20</p>	<p>D</p>  <p>JCBC SCREW M6 x 35MM</p> <p>x8</p>	<p>E</p>  <p>JCBC SCREW M6 x 50MM</p> <p>x2</p>
<p>F</p>  <p>SPRING WASHER M6 x 12MM</p> <p>x10</p>	<p>G</p>  <p>FLAT WASHER M6 x 19MM</p> <p>x10</p>	<p>H</p>  <p>SPRING WASHER M8 x 13MM</p> <p>x4</p>	<p>I</p>  <p>FLAT WASHER M8 x 22MM</p> <p>x4</p>	<p>J</p>  <p>L - KEY M4 x 100MM</p> <p>x1</p>
<p>K</p>  <p>L - KEY M5 x 65MM</p> <p>x1</p>	<p>L</p>  <p>SUPPORT LEG ADJUSTABLE FEET</p> <p>x4</p>			

# ASSEMBLY INSTRUCTION

STEP 1

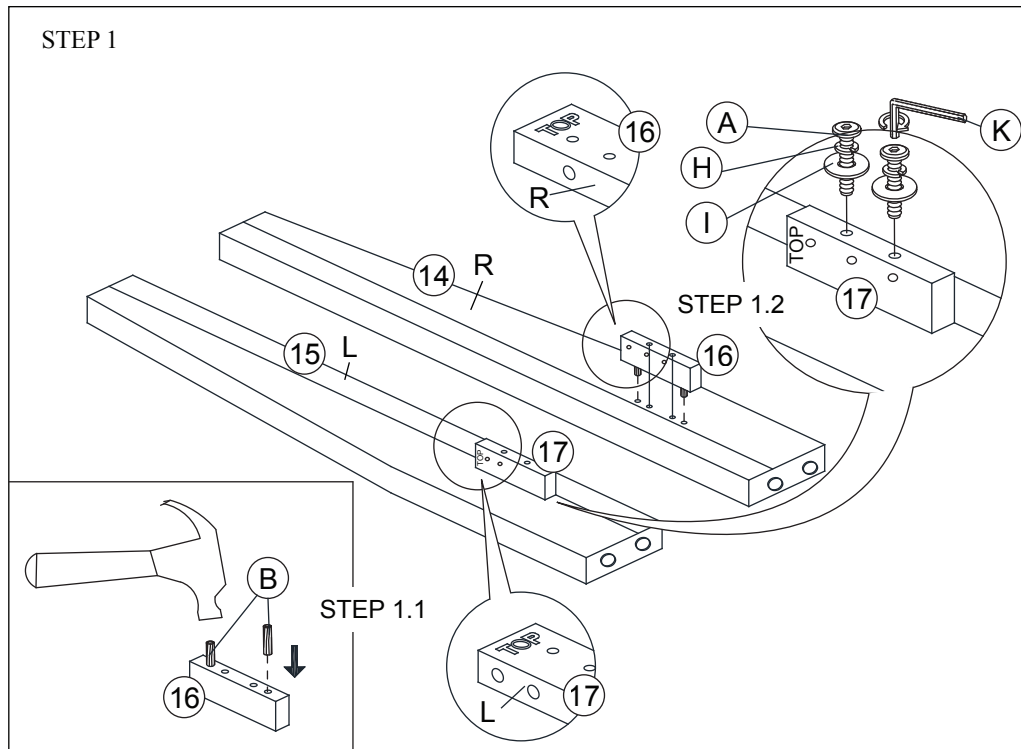

STEP 2

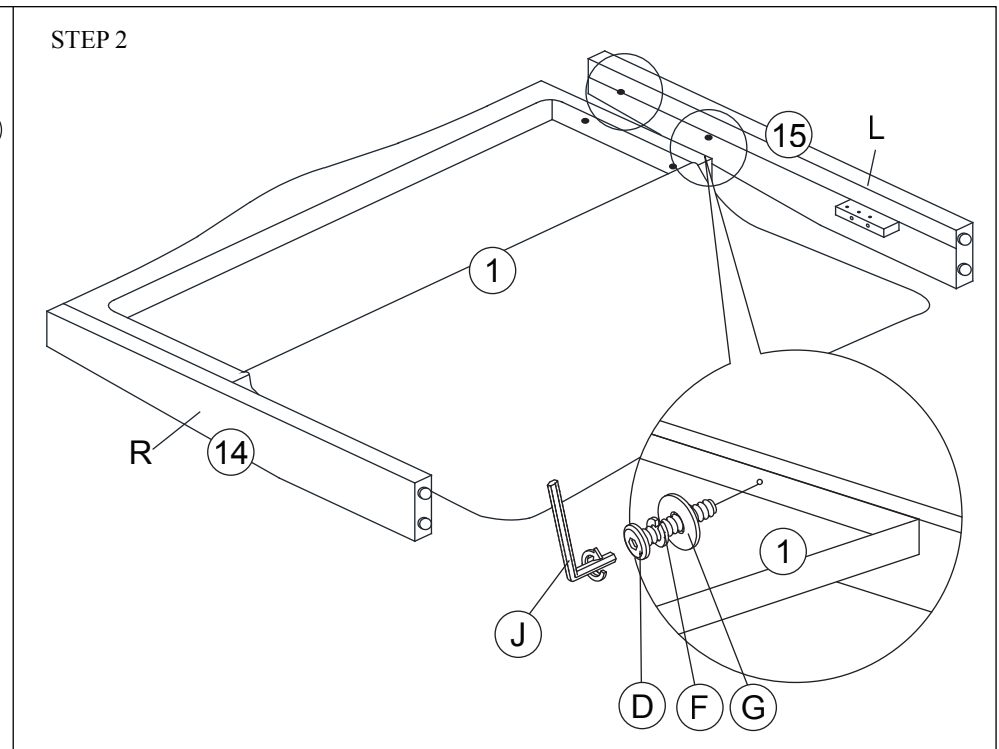

STEP 3

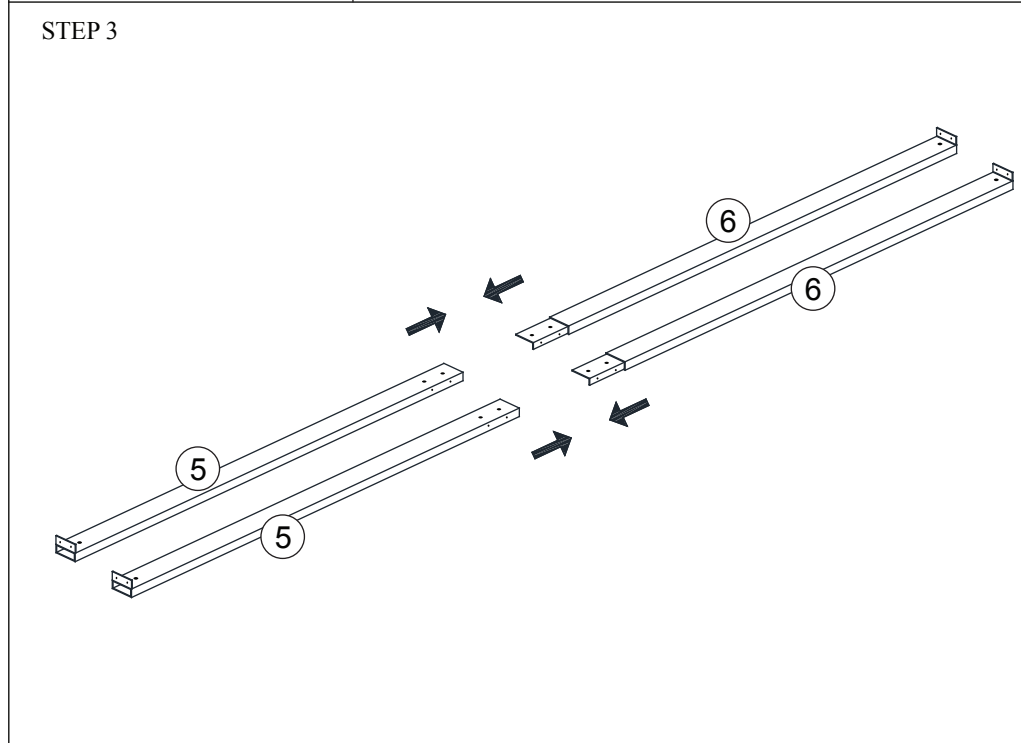

STEP 4

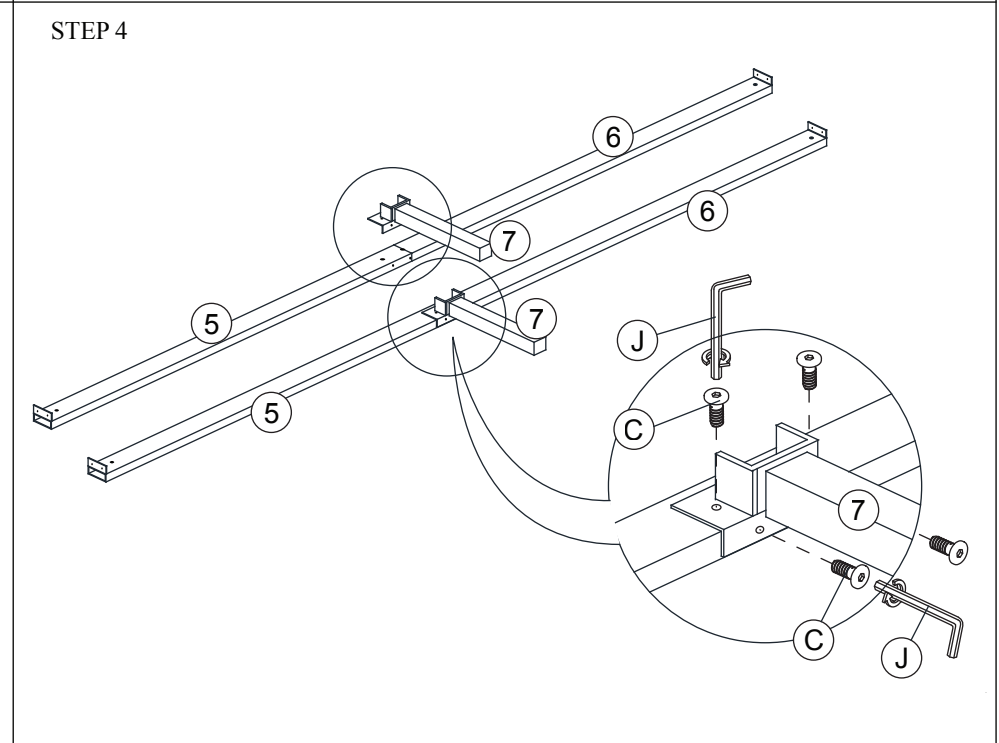

# ASSEMBLY INSTRUCTION

STEP 5

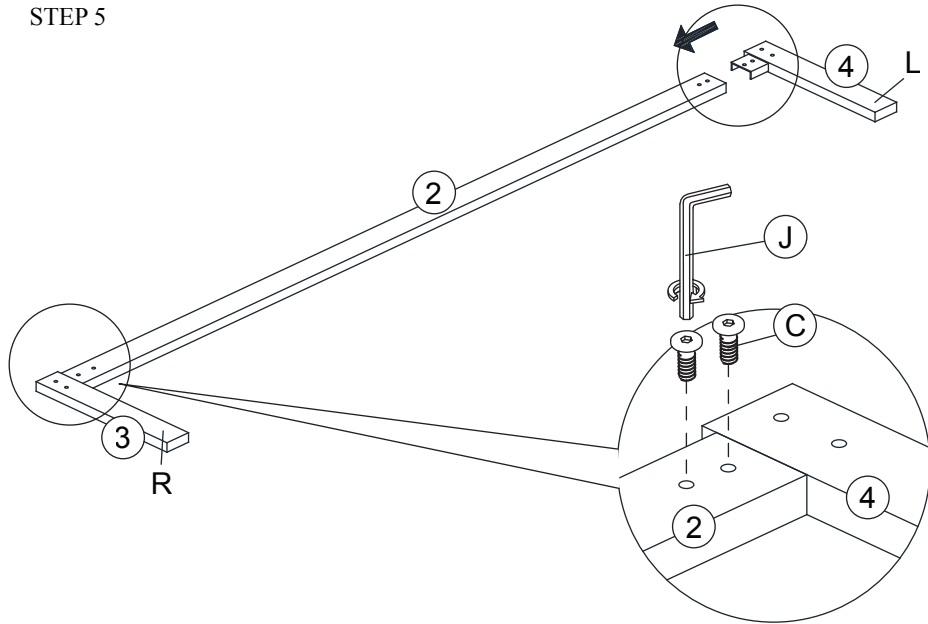

STEP 6

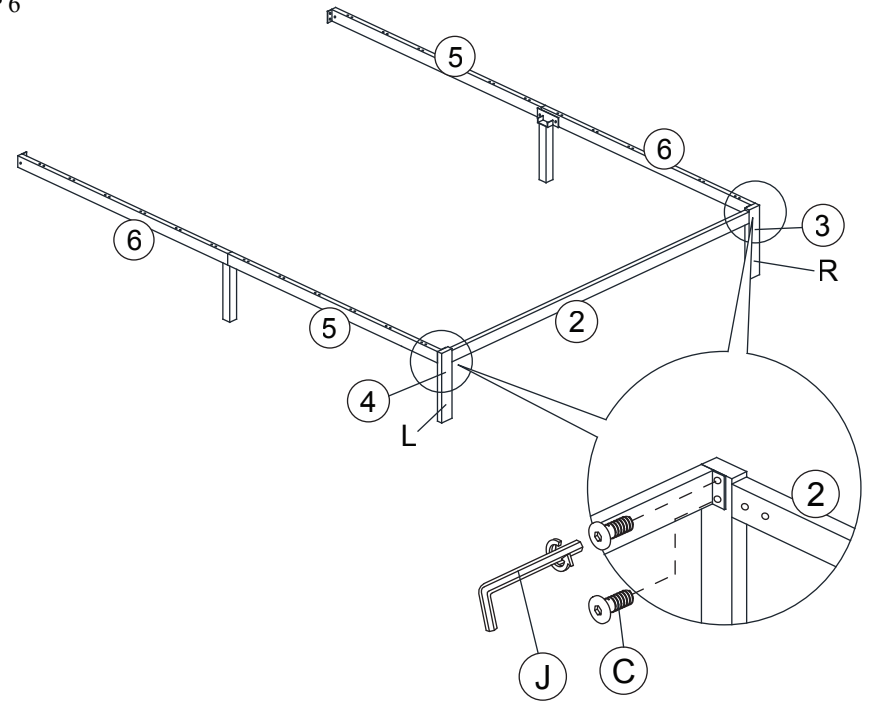

STEP 7

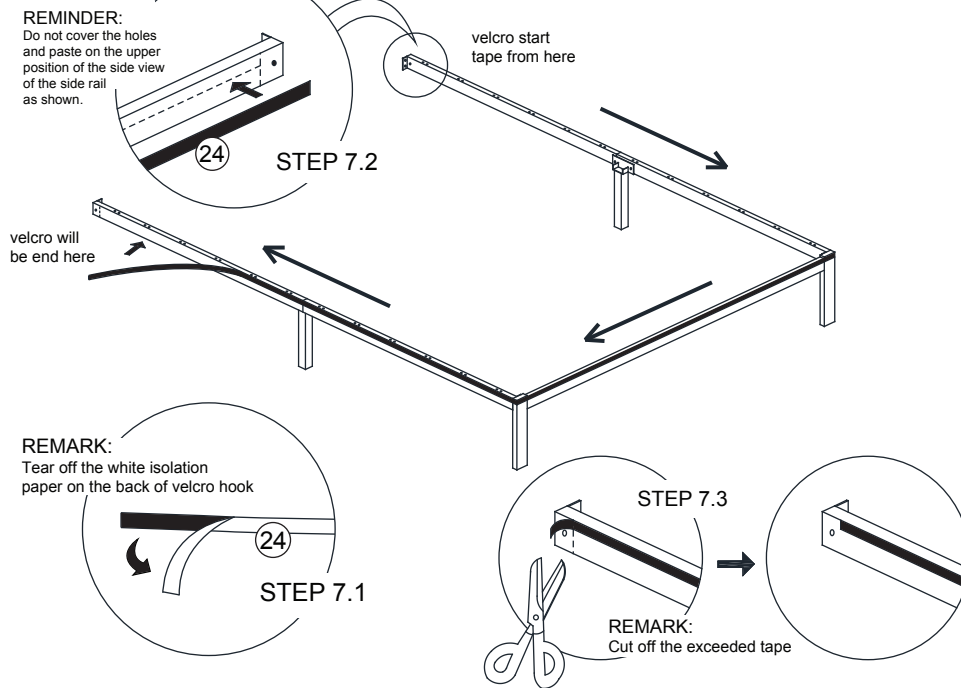

STEP 8

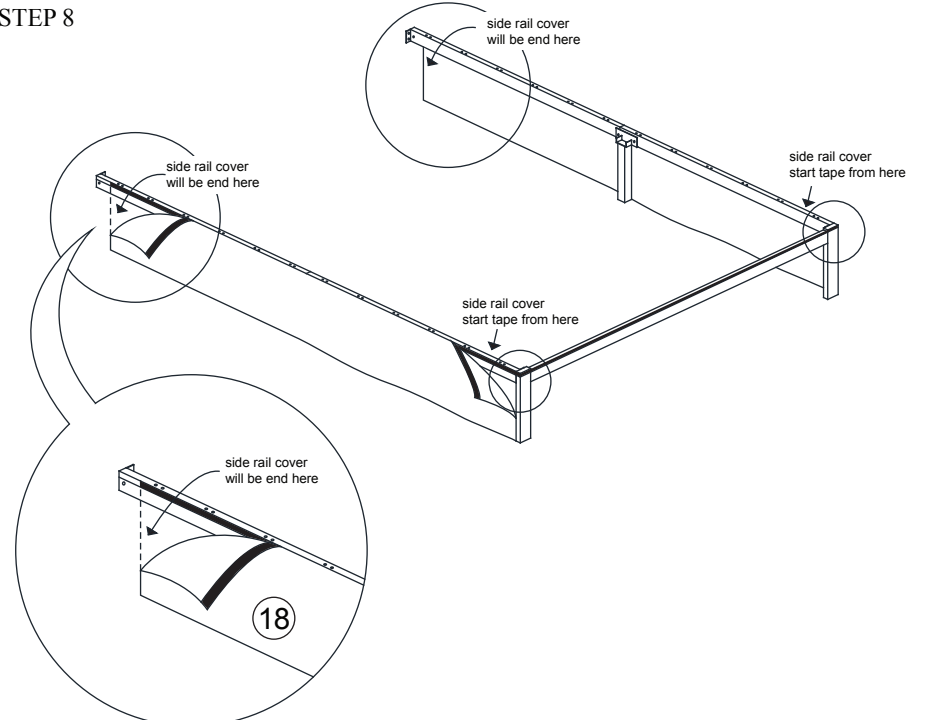

# ASSEMBLY INSTRUCTION

STEP 9

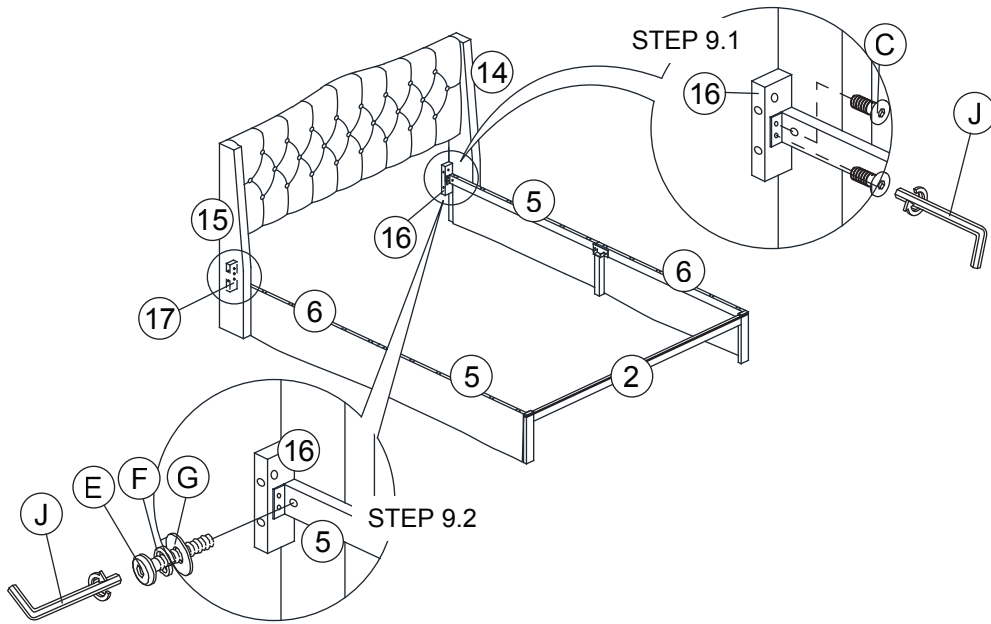

STEP 10

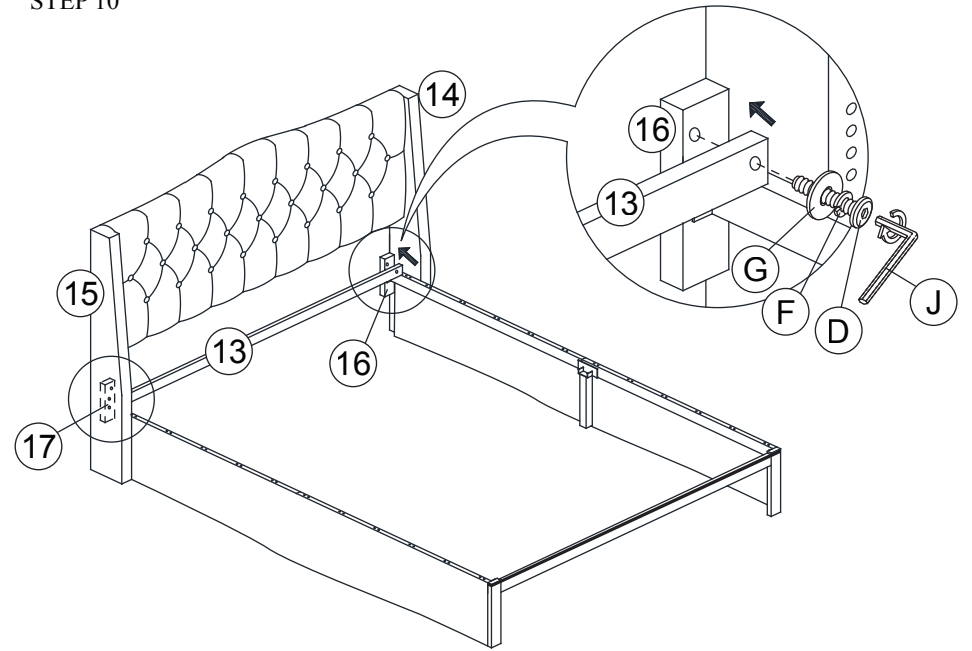

STEP 11

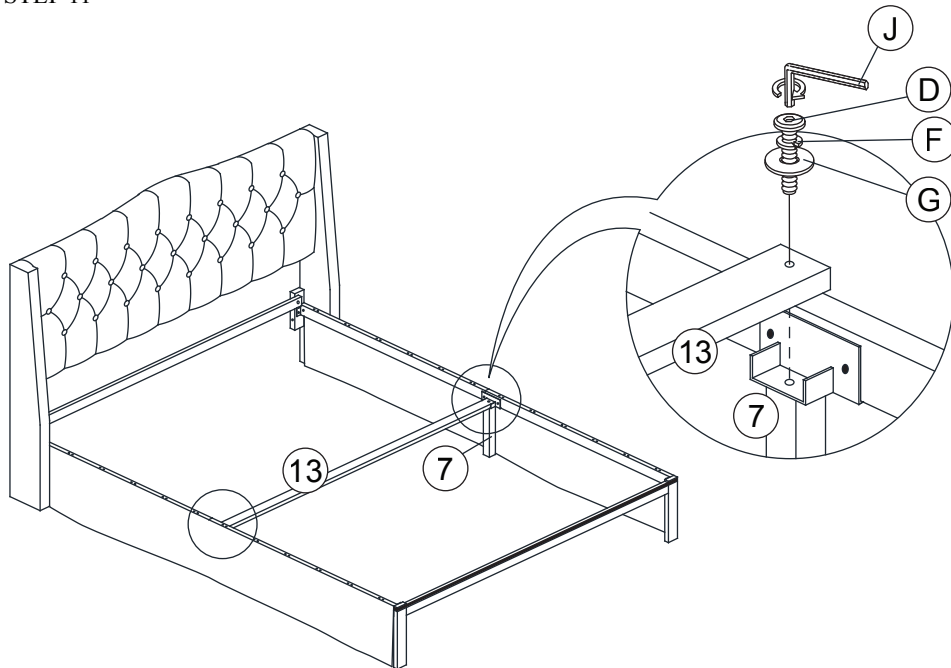

STEP 12

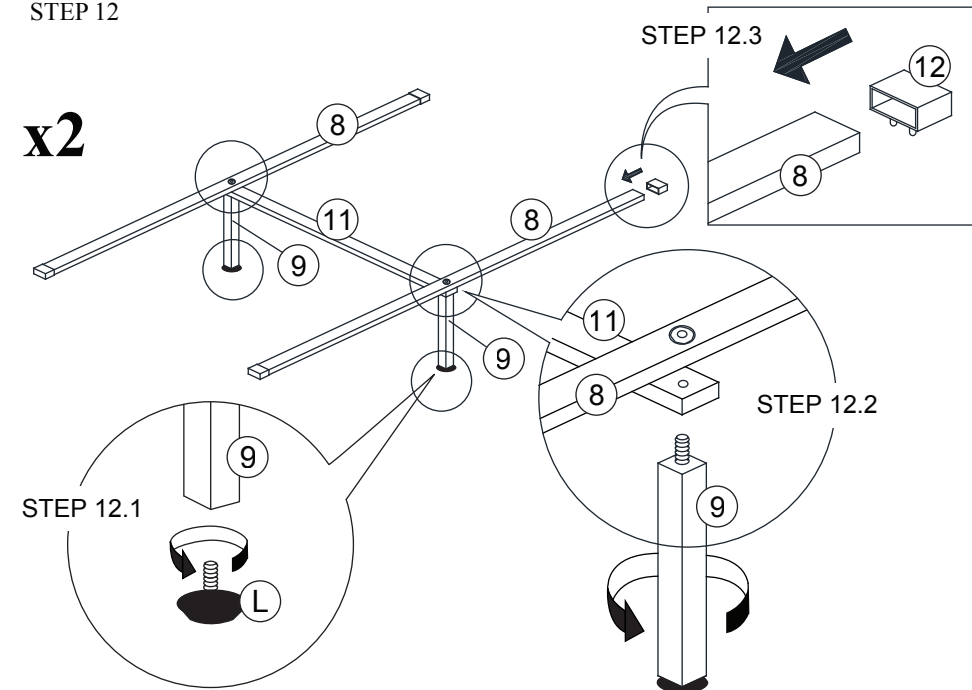

# ASSEMBLY INSTRUCTION

STEP 13

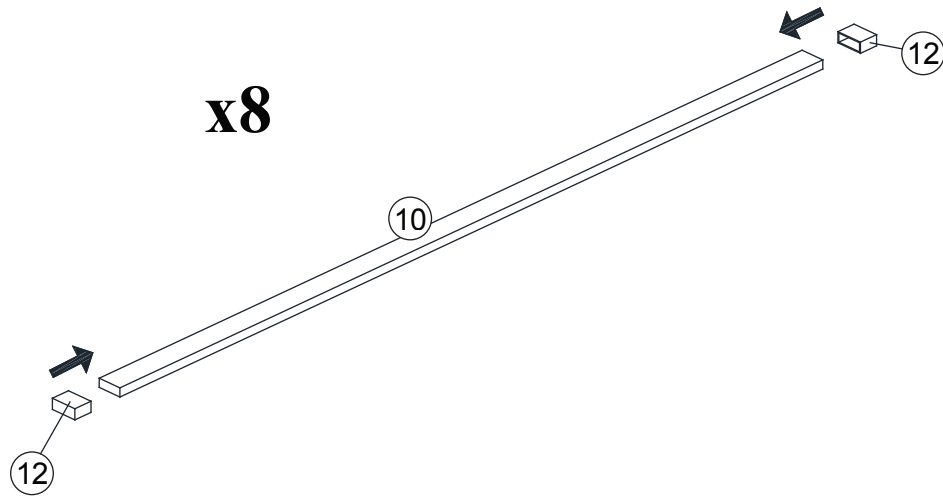

STEP 14

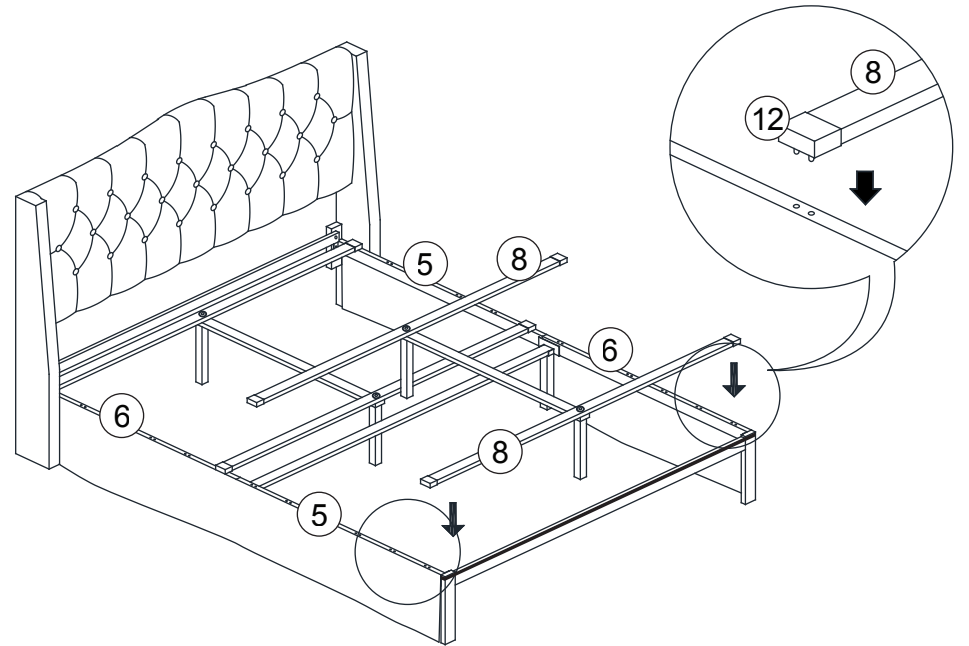

STEP 15

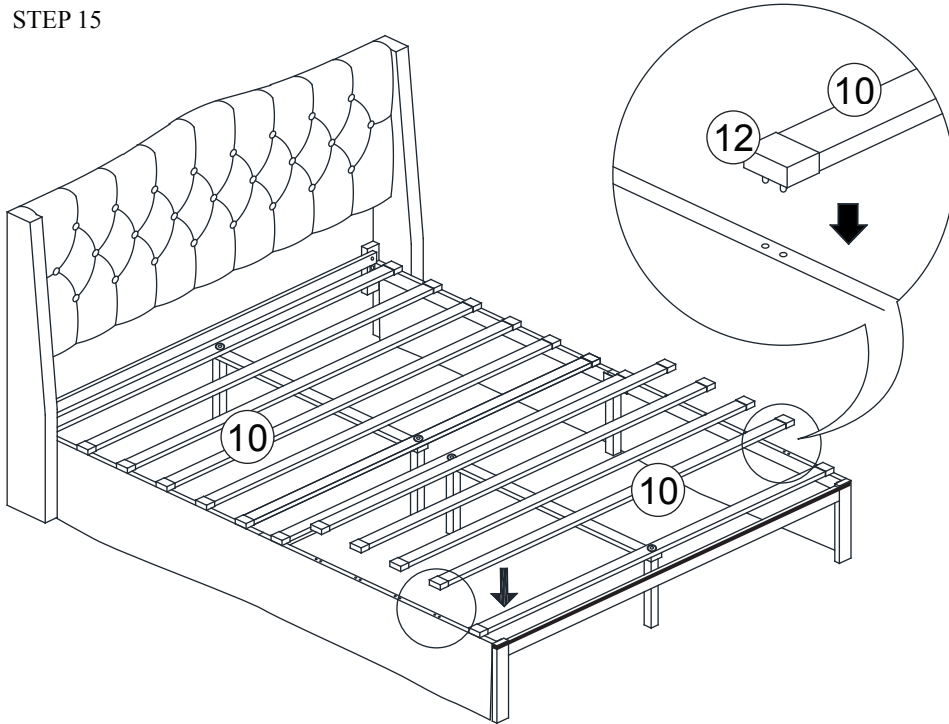

STEP 16

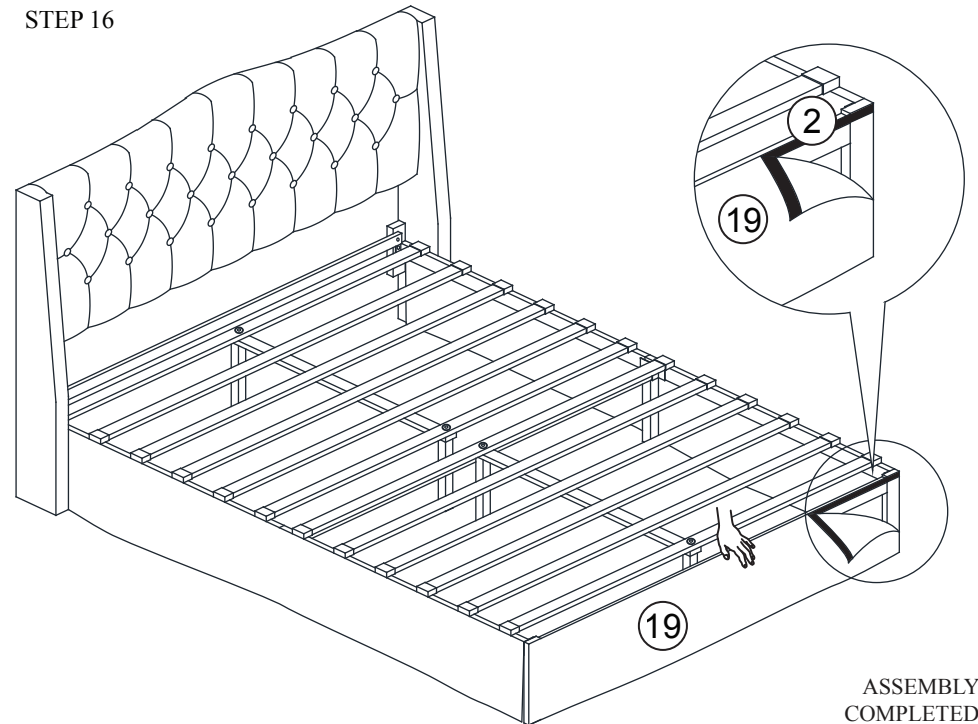

ASSEMBLY  
COMPLETED