

ASSEMBLY INSTRUCTIONS



Fine Furniture for every stage of life

Dining Table

ASSEMBLY INSTRUCTIONS

ASSEMBLY TIPS :

1. Remove hardware from box and sort by size.
2. Please check to see that all hardware and parts are present prior to start of assembly.
3. Please follow attached instructions in the same sequence as numbered to assure fast & easy assembly.



WARNING !



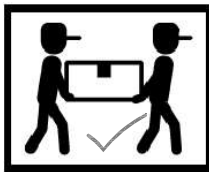



1. Don't attempt to repair or modify parts that are broken or defective. Please contact the store immediately.
2. This product is for home use only and not intended for commercial establishments.



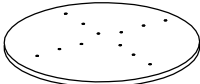





ASSEMBLY TIME

25 MINUTES

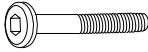
PARTS IDENTIFICATION

A	TOP		1PC
B	LEG FRAME		4PCS
C	UPPER CROSSBAR		1PC
D	LOWER CROSSBAR		1PC
E	LEG SUPPORT FRAME		1PC
F	LEG SUPPORT FRAME COVER		1PC

HARDWARE IDENTIFICATION

1	ALLEN WRENCH (M4 x 110mm - BLK)		1PC
2	BOLT (M6 x 40mm - RBW)		20PCS
3	LOCK WASHER (1/4" - BLK)		20PCS
4	SMALL FLAT WASHER (M6 x 13mm - RBW)		12PCS
5	BIG FLAT WASHER (1/4" - RBW)		8PCS
6	WOOD DOWEL (M10 X 30MM)		4PCS
7	ADJUSTABLE LEVELER (M8 X 20MM)		4PCS

NOTE :

Phillips head screw driver is required in the assembly process ; however, manufacturer not provide this item.

ASSEMBLY INSTRUCTIONS

STEP 1

ATTENTION! PLEASE REMOVE ALL SCREWS AND WOOD BLOCKS BEFORE ASSEMBLE.

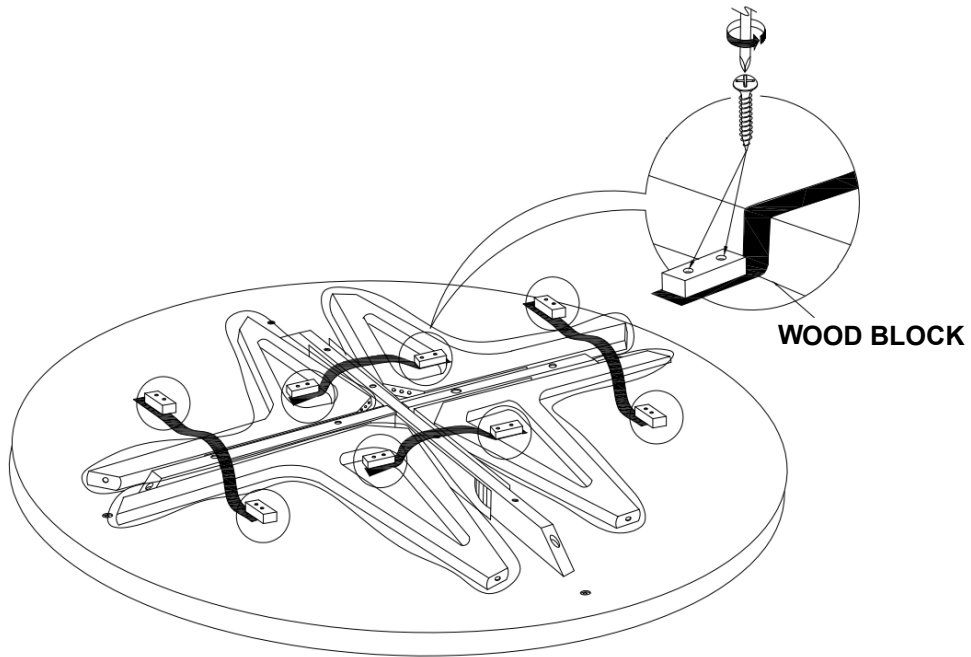

STEP 2

ATTENTION! PLEASE REMOVE ALL BOLTS, LOCK WASHERS AND FLAT WASHERS IN THIS STEP AND USE ALL HARDWARE IN STEP 6.

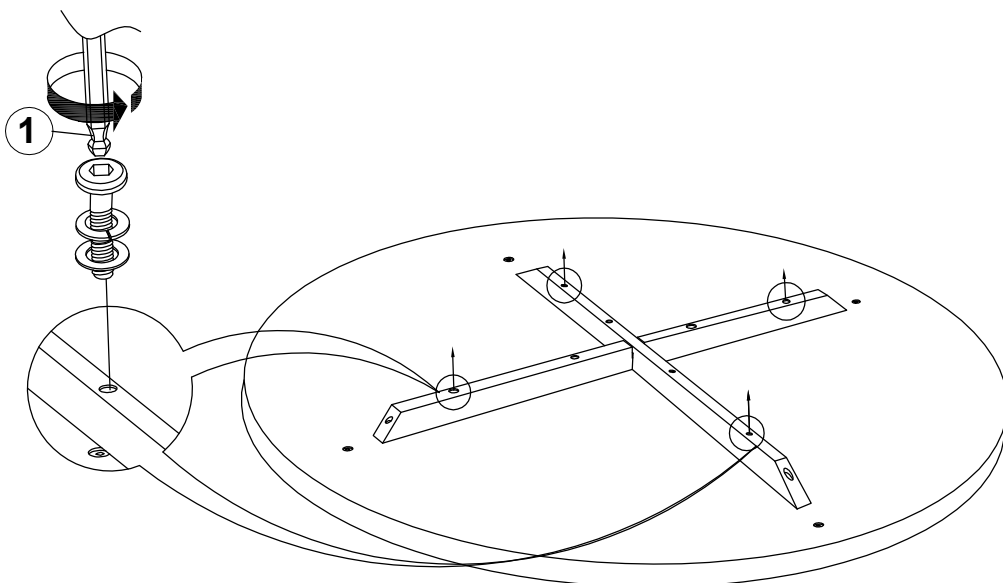

ASSEMBLY INSTRUCTIONS

STEP 3

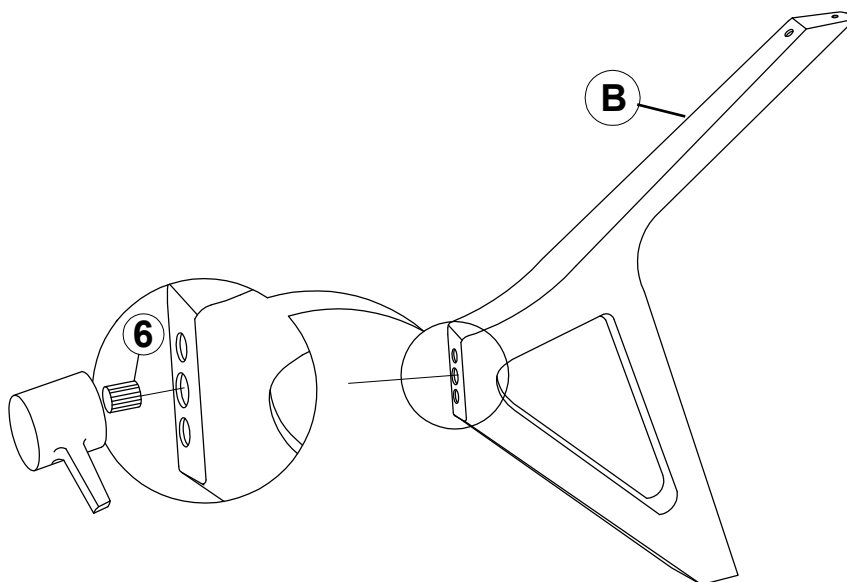

STEP 4

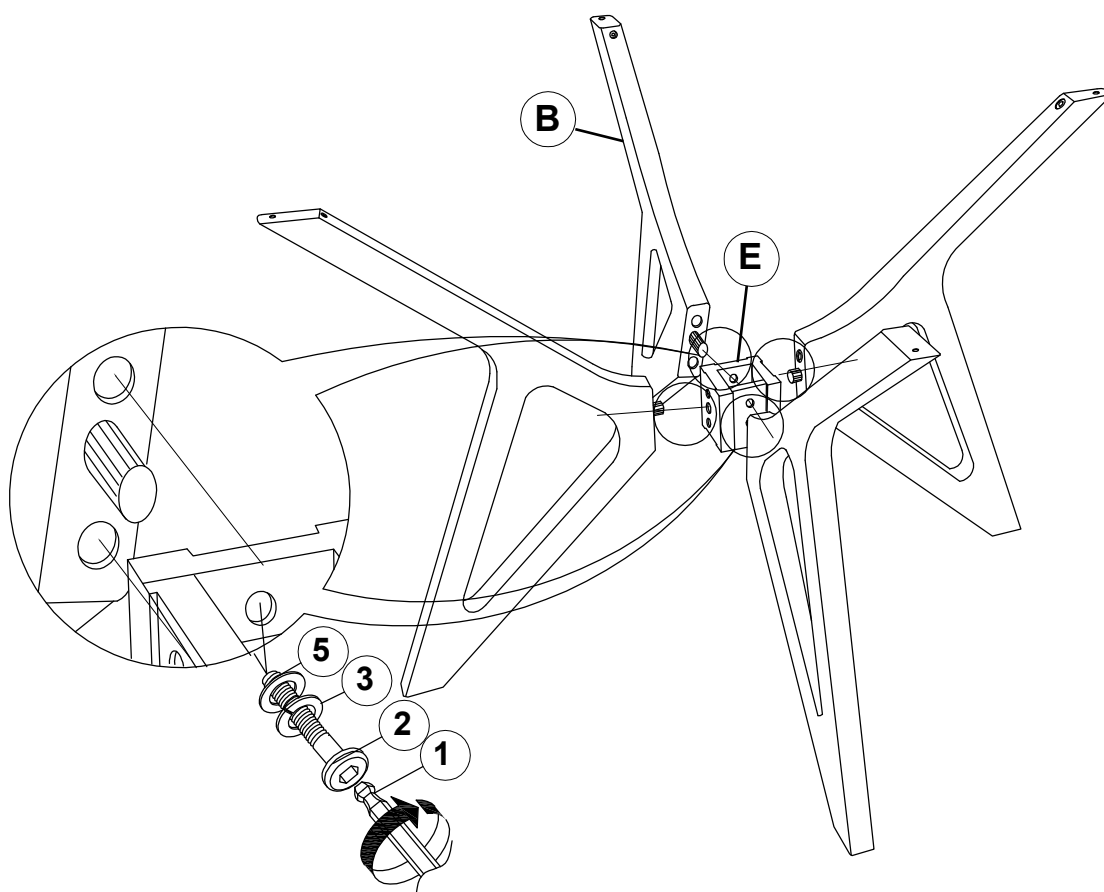

ASSEMBLY INSTRUCTIONS

STEP 5

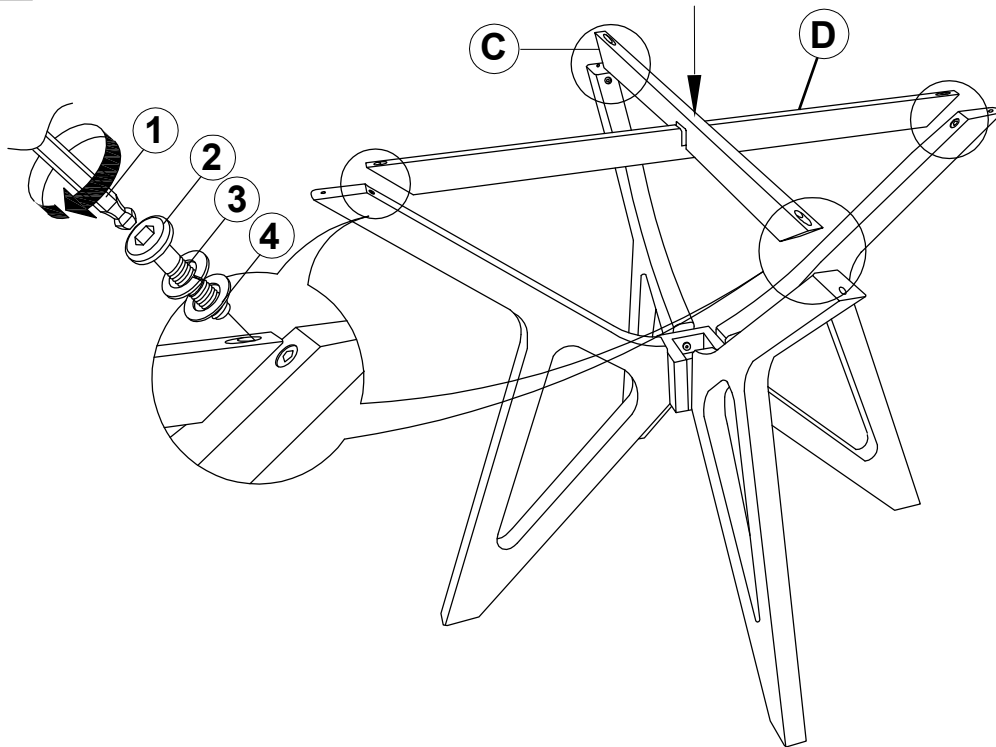

STEP 6

ATTENTION! PLEASE USE ALL BOLTS, LOCK WASHERS AND FLAT WASHERS IN STEP 2

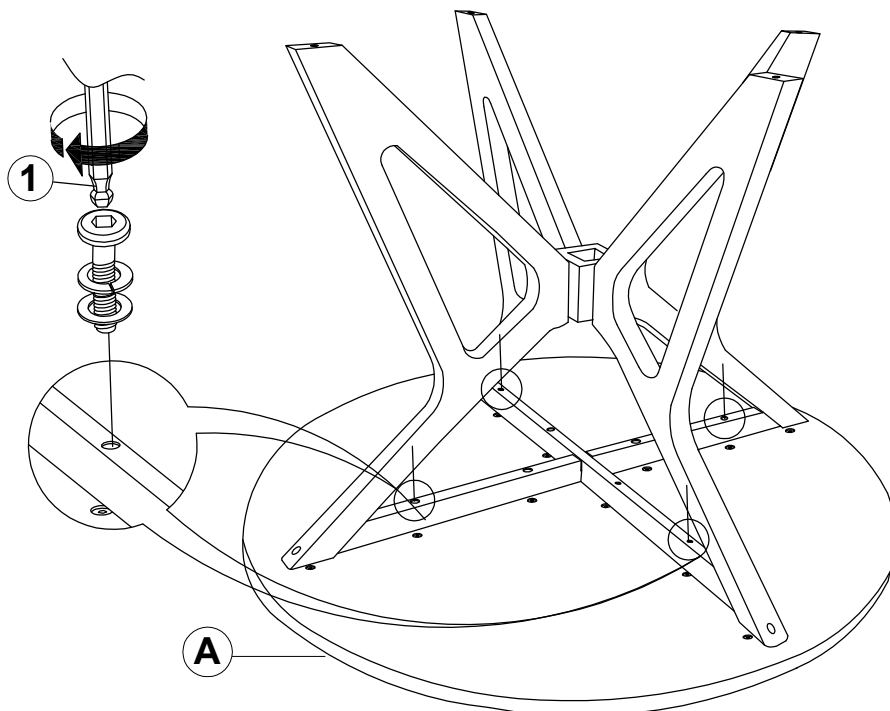

ASSEMBLY INSTRUCTIONS

STEP 7

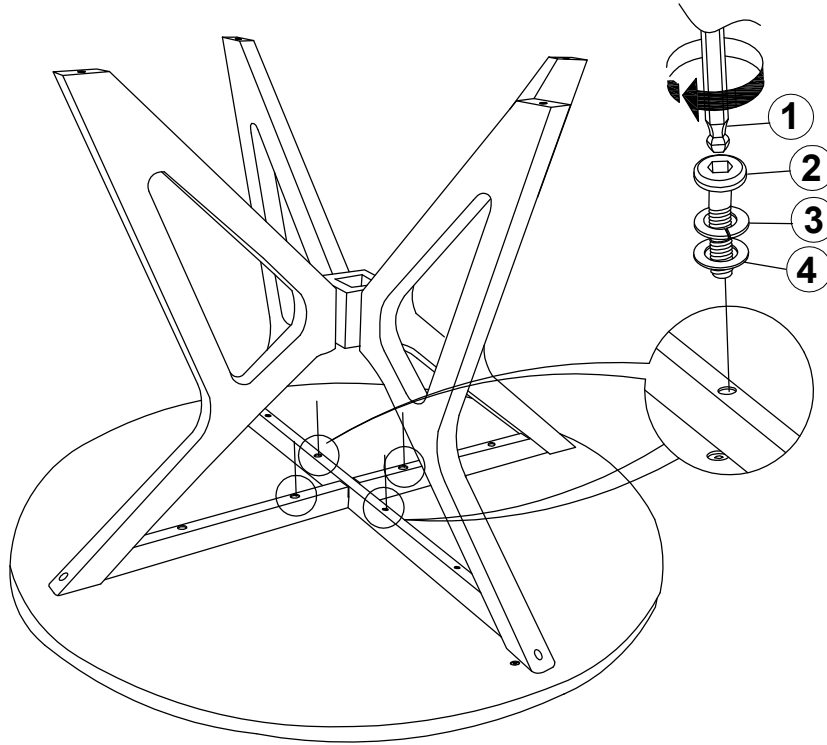

STEP 8

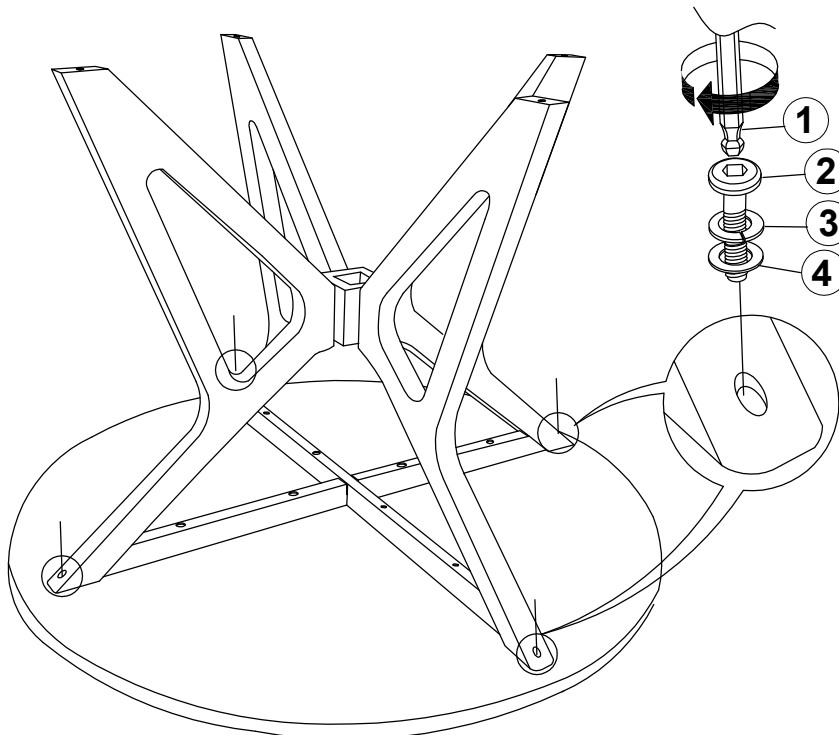

ASSEMBLY INSTRUCTIONS

STEP 9

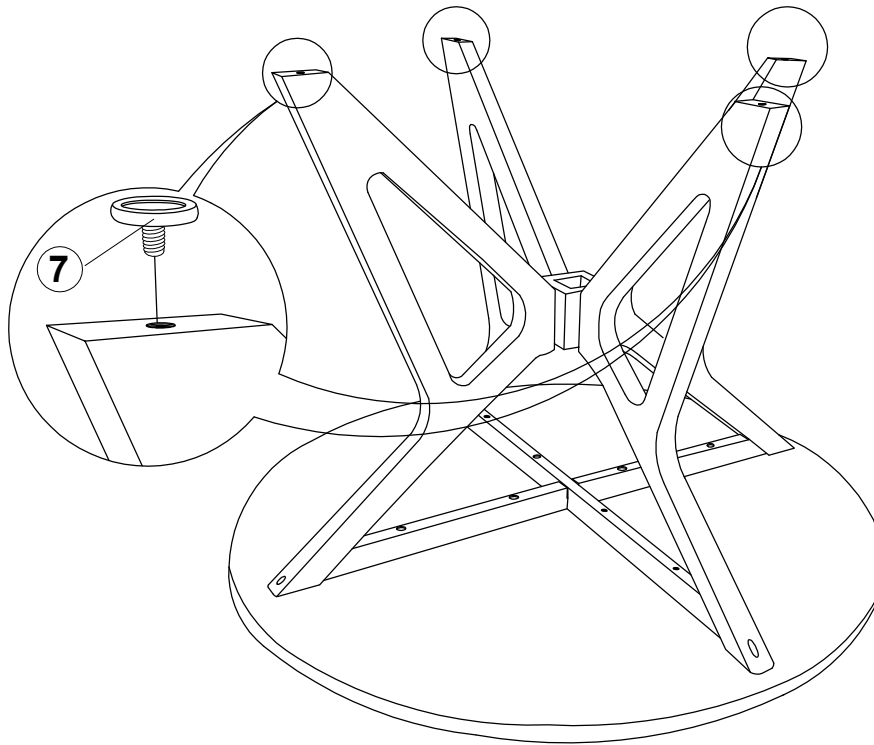

STEP 10 COMPLETE

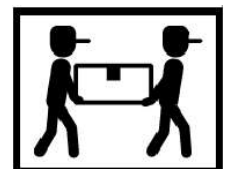

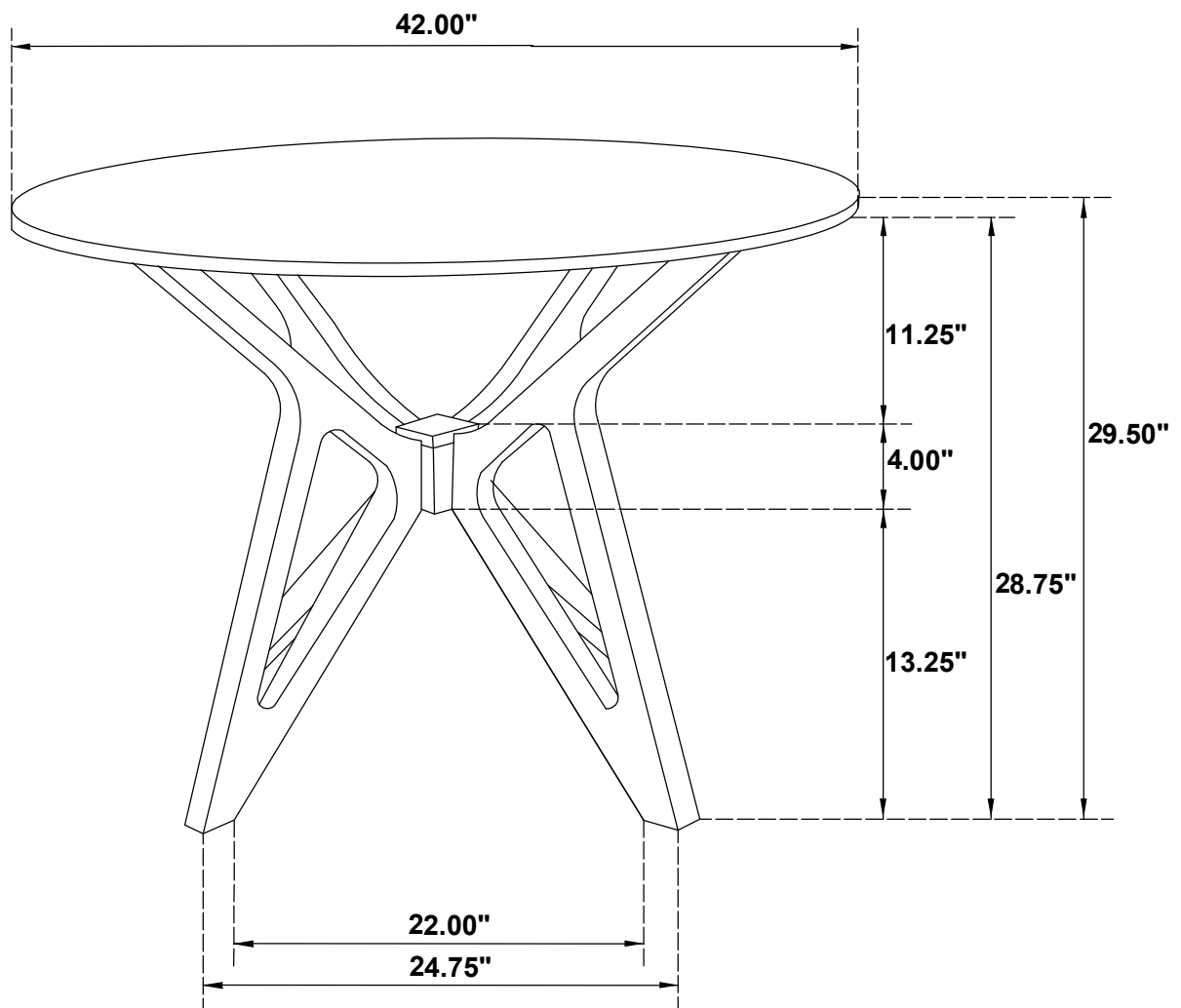

Note: Dimension tolerance $\pm 5\%$

ASSEMBLY INSTRUCTIONS



Fine Furniture for every stage of life

Side Chair

ASSEMBLY INSTRUCTIONS

ASSEMBLY TIPS :

1. Remove hardware from box and sort by size.
2. Please check to see that all hardware and parts are present prior to start of assembly.
3. Please follow attached instructions in the same sequence as numbered to assure fast & easy assembly.



WARNING !

1. Don't attempt to repair or modify parts that are broken or defective. Please contact the store immediately.
2. This product is for home use only and not intended for commercial establishments.

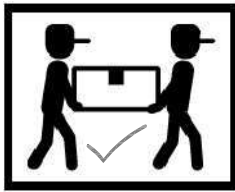

ASSEMBLY TIME

15 MINUTES

PARTS IDENTIFICATION

A BACKREST



1PC

B UPPER LEG FRAME

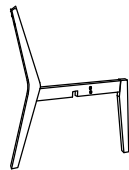

1PC

C LOWER LEG FRAME

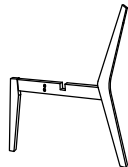

1PC

D WOOD CLEAT



1PC

E SEAT CUSHION



1PC

HARDWARE IDENTIFICATION

1 ALLEN WRENCH
(M4 x 110MM - BLK)



1PC

2 LONG BOLT
(M6 x 60MM - RBW)

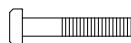

4PCS

3 MEDIUM BOLT
(M6 x 35MM - RBW)



4PCS

4 SHORT BOLT
(M6 x 25MM - RBW)



4PCS

5 HEX HEAD BOLT
(M7 x 50MM - ZB)

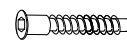

1PC

6 LOCK WASHER
(1/4" - BLK)



8PCS

7 FLAT WASHER
(M6 X 13MM - RBW)



4PCS

8 WOOD PLUG
(Ø14.5 X 9MM)



4PCS

NOTE :

Quantities shown are for one chair.

Phillips head screw driver is required in the assembly process; However, manufacturer not provide this item.

ASSEMBLY INSTRUCTIONS

STEP 1

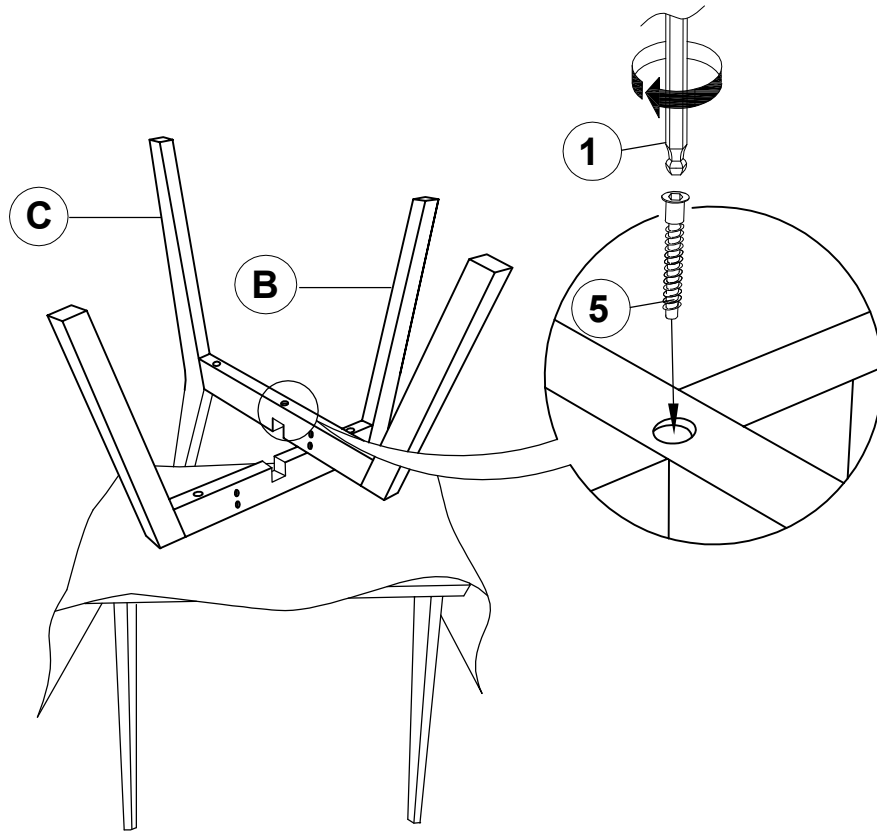

STEP 2

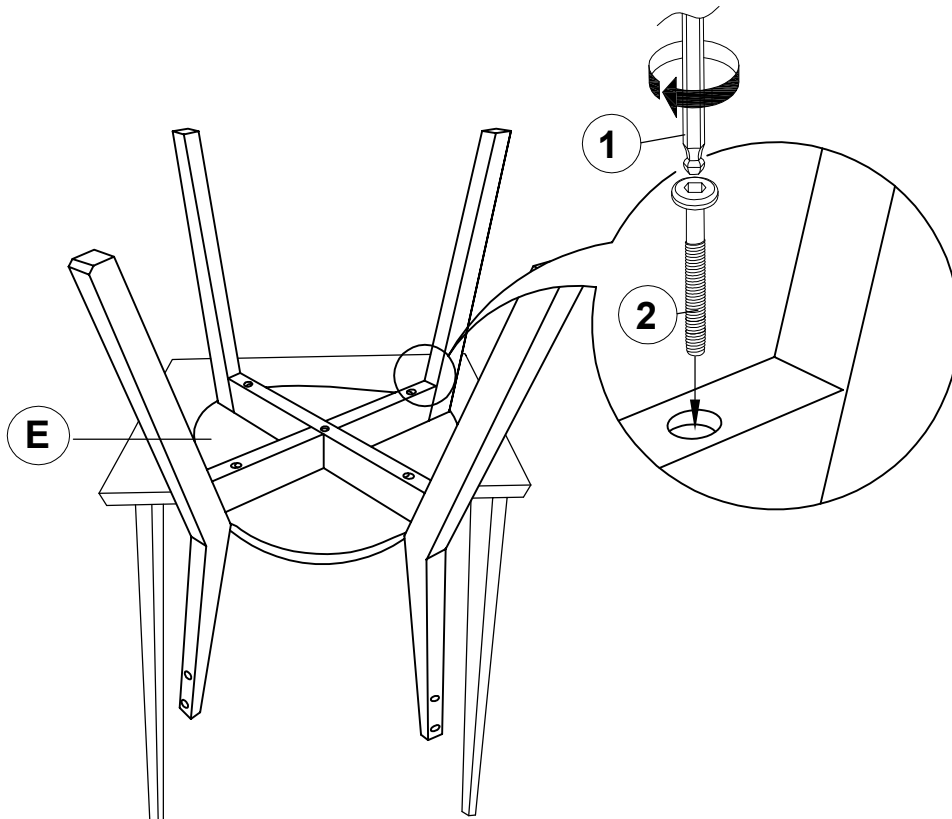

ASSEMBLY INSTRUCTIONS

STEP 3

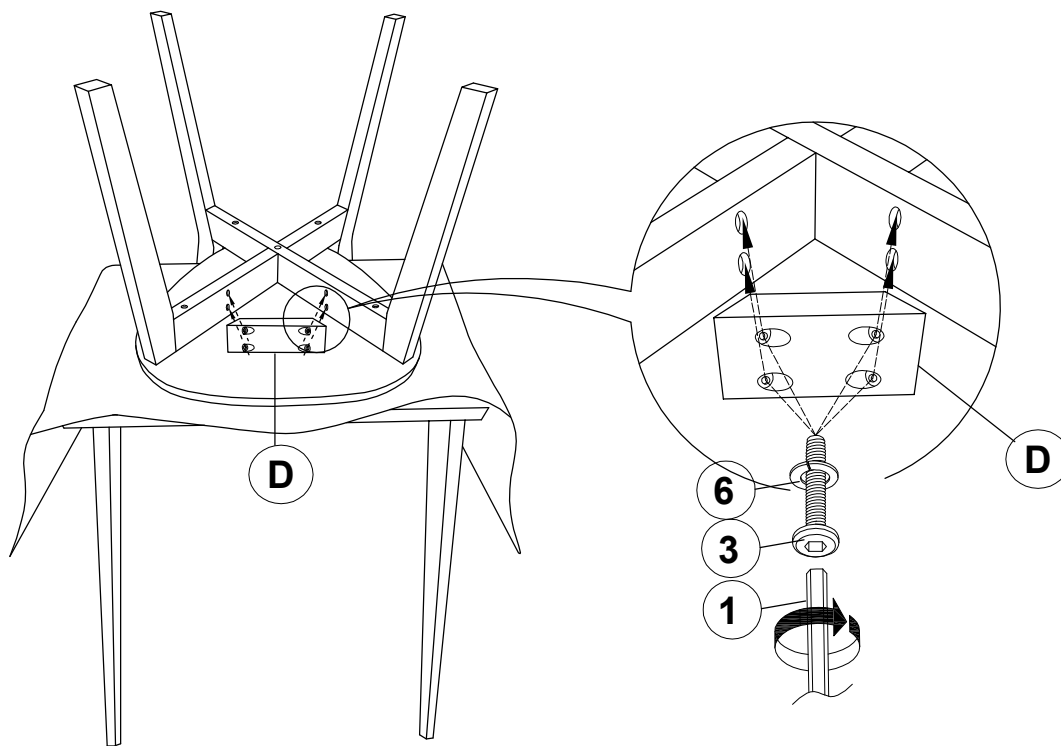

STEP 4

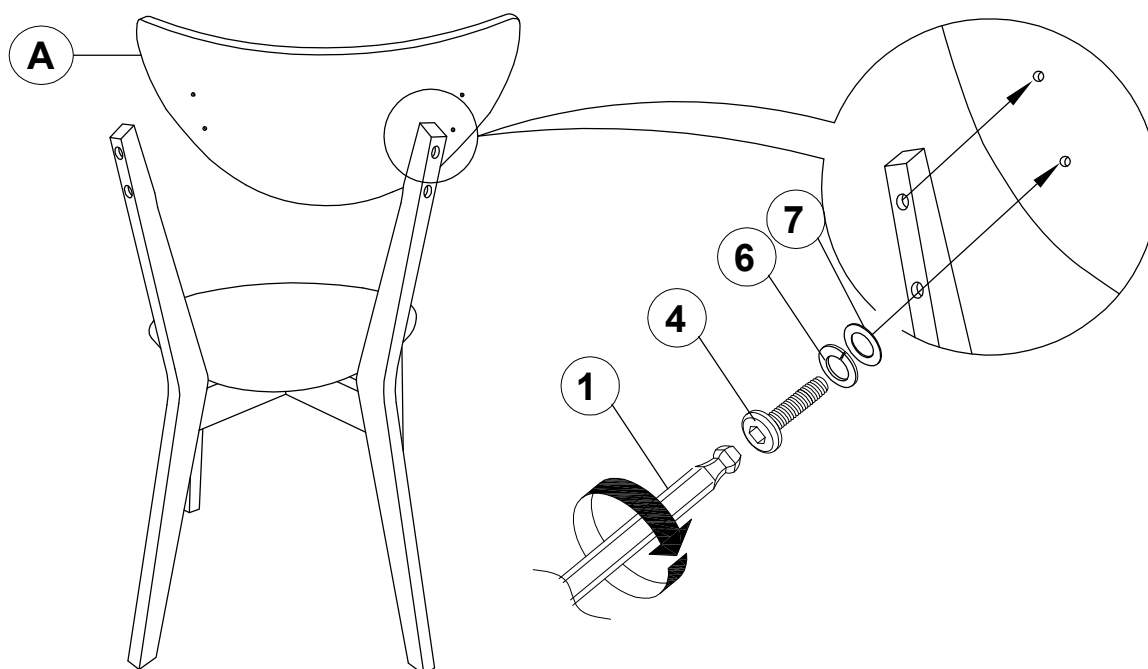

ASSEMBLY INSTRUCTIONS

STEP 5

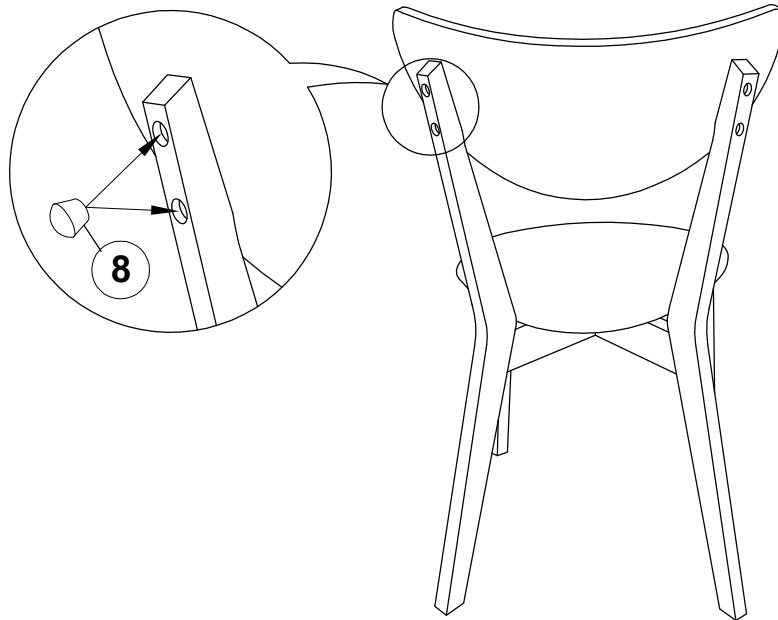

STEP 6 COMPLETE

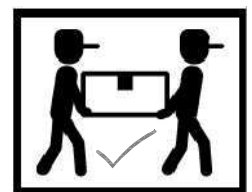
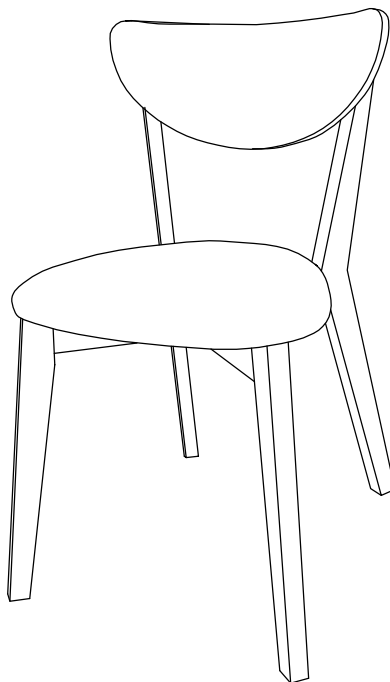

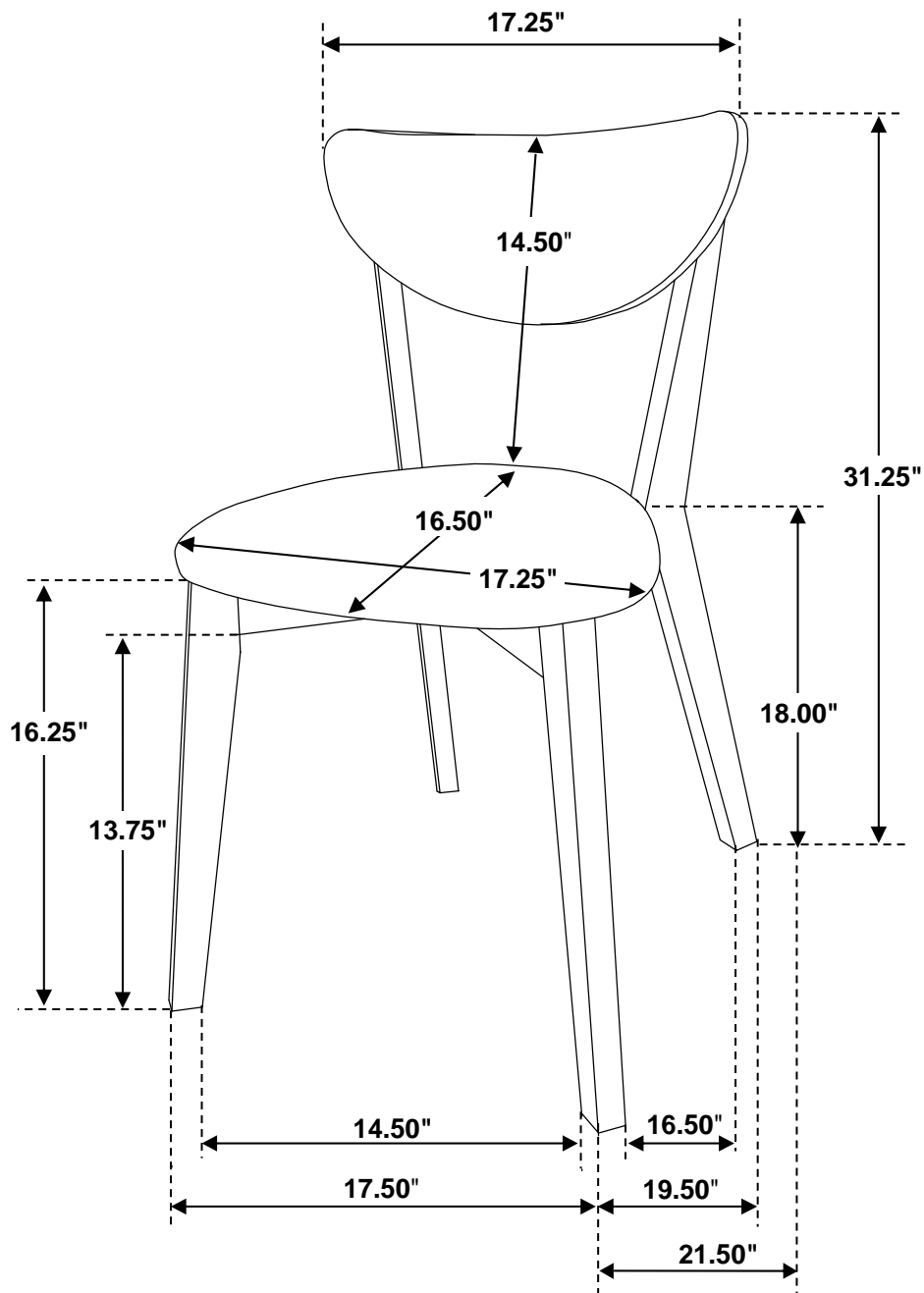

Note: Dimension tolerance $\pm 5\%$