

SORRENTO 4

Assembly Instructions

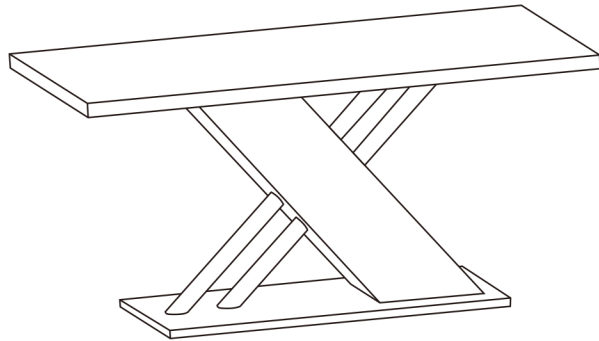

Safety and Care Advice

Important – Please read these instructions fully before starting assembly

Check you have all the components and tools listed.

Remove all fittings from the plastic bags and separate them into their groups.

Keep children and animals away from the work area, small parts could choke if swallowed.

Make sure you have enough space to layout the parts before starting.

Assemble the item as close to its final position (in the same room) as possible.

Do not overtighten the nuts to avoid causing damage to the threads.



We do not recommend the use of power drill/drivers **for inserting screws**, as this could damage the unit. Only use hand screwdrivers and Allen keys.









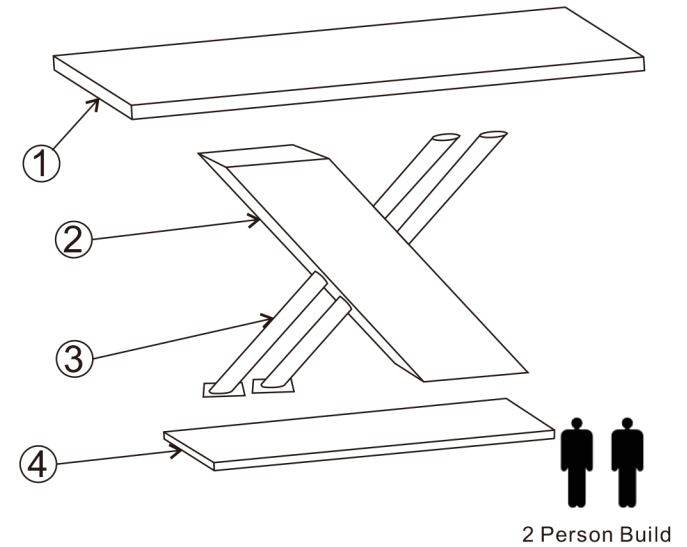

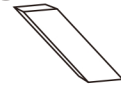



Care and maintenance

Only clean using a damp cloth and mild detergent, do not use bleach or abrasive cleaners.

From time to time check that there are no loose screws on this unit.

This product should not be discarded with household waste. Take to your local authority waste disposal centre.



 x1	 x1	 x2	 x1
 M8*65mm x4	 M8*20mm x8	 M8*10mm x12	 M8*18mm x8
 M8*30mm x8	 M8*22mm x6	 x1	 x1
 Ø35x4	 Ø30x6	 Ø40 x4	 M8 x4

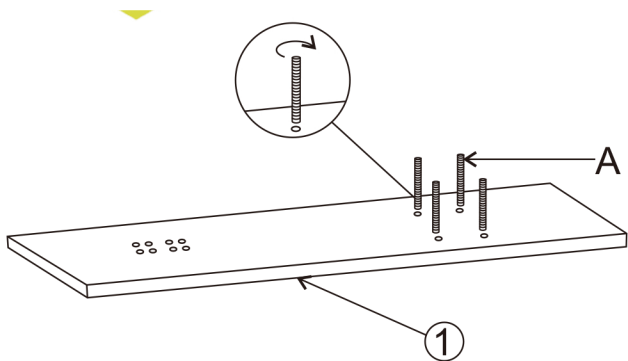

Step 1

Put the pieces on a soft flat surface e.g. a carpet to avoid scratching or bumping. Insert part A x4 into the assembly holes of part 1 (the table top).

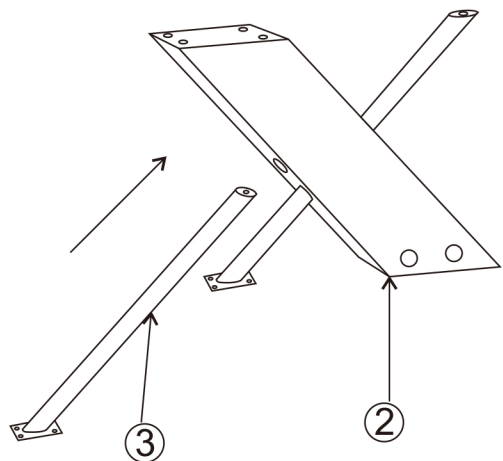

Step 2

Insert the metal rods (part 3) into the table leg (part 2) as shown. Pay attention to the direction of the rods so that the base feet are facing downwards.

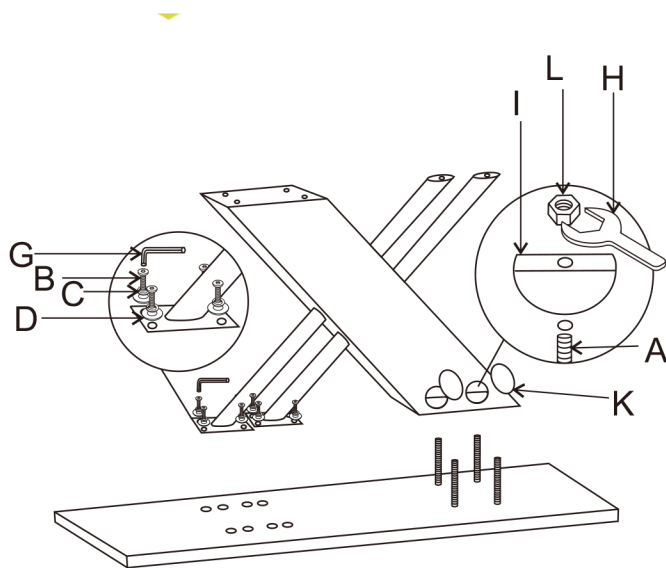

Step 3

Insert part 2/3 onto the table top using the parts shown. Please note **DO NOT FULLY TIGHTEN THE SCREWS**. Keep these screws slightly loose so the table angle can be adjusted and fixed once assembly is complete. Then use fixing K to cover the holes on the table legs (part 2) as shown

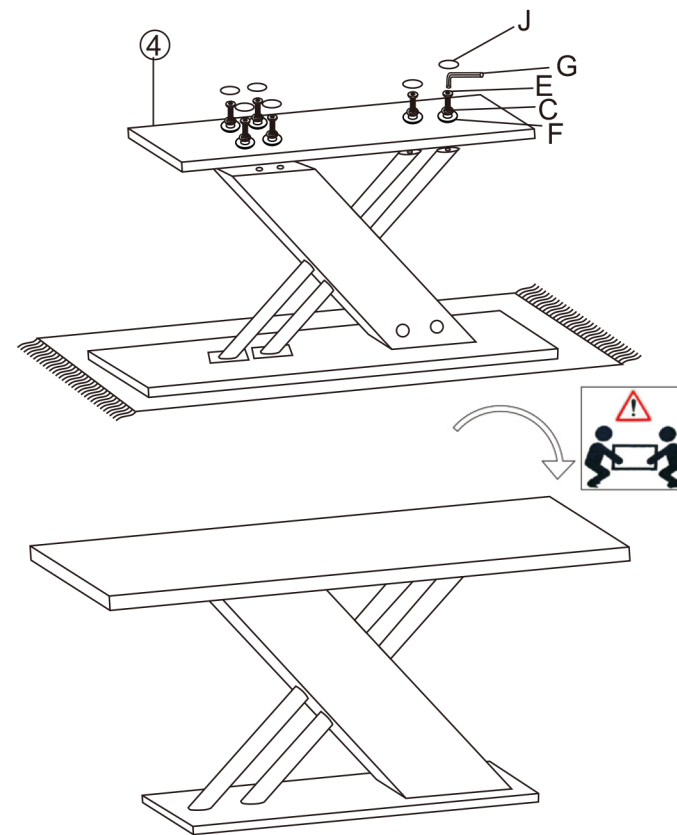

Step 4

Attach the table base (part 4) to the table legs using fixings G, E, C, F. Use fixing J to cover the holes on the table Base (part 4).

Step 5

Tighten all screws/bolts fully and then turn the table over using two people. Assembly is now complete