

Kitchen Island

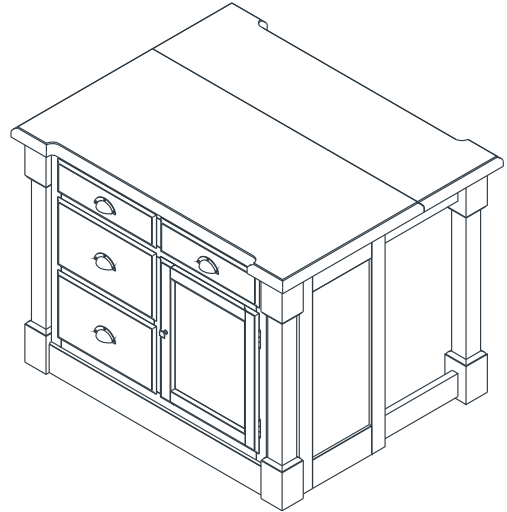

IMPORTANT NOTE

Carefully remove all the parts from the carton and put them individually on a soft cloth to prevent scratches or other damages occurring to the parts.

We have taken great care in the design of this product and request that you carefully and strictly follow our assembly instructions to ensure a completed product as it was designed.

Part List

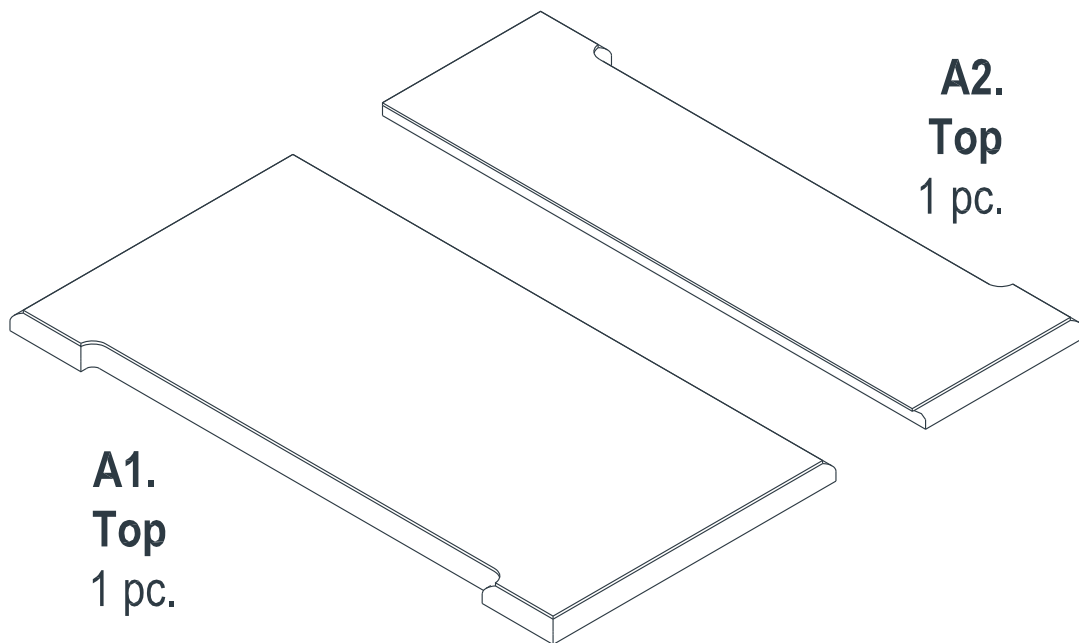

Hardware List



3/4" Flat Head Screw
12 pcs. (+1 extra)

For assembly see instructions in carton

Kitchen Island

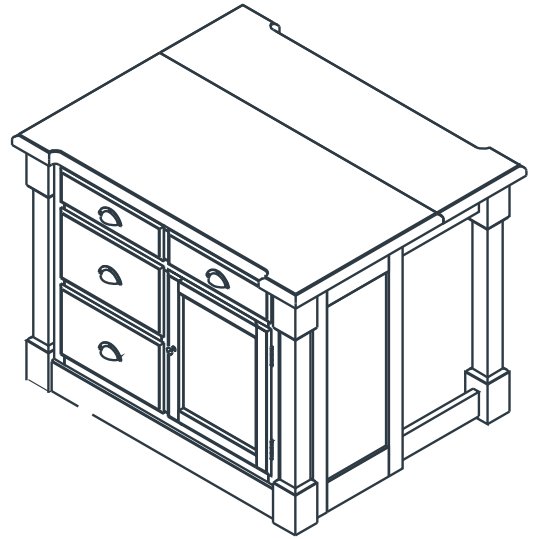

IMPORTANT NOTE

Carefully remove all the parts from the carton and put them individually on a soft cloth to prevent scratches or other damages occurring to the parts.

We have taken great care in the design of this product and request that you carefully and strictly follow our assembly instructions to ensure a completed product as it was designed.



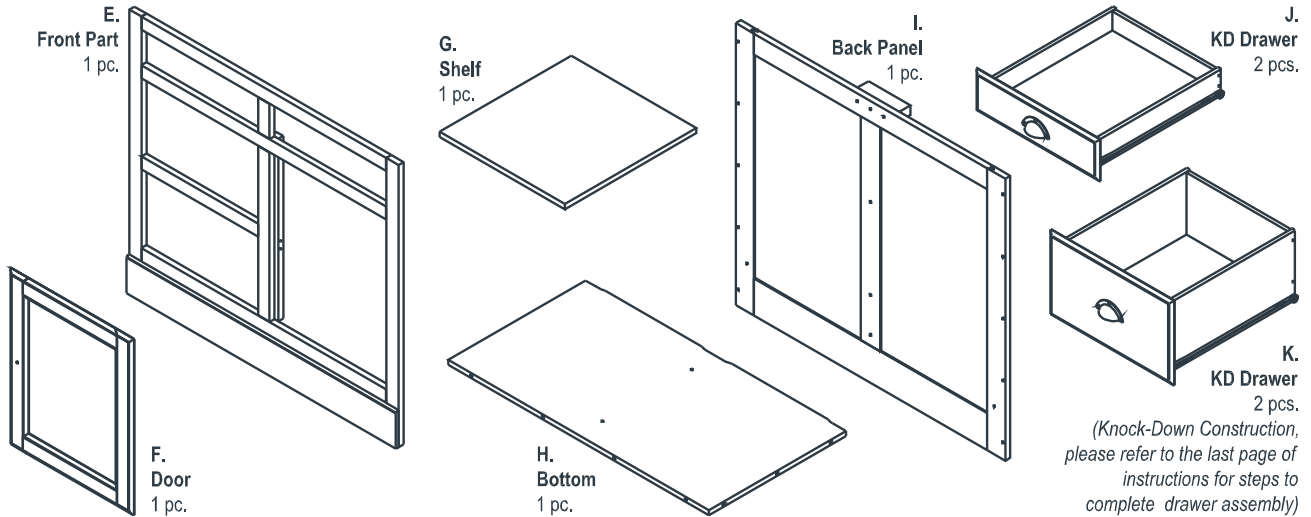



Part List

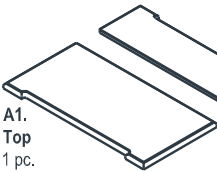
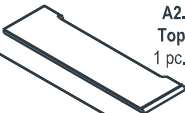

Hardware List



For assembly also need the following :

Aspen Kitchen Island with Wood Top or Aspen Kitchen Island with Granite Top		Carton quantity: 1	Aspen Kitchen Island					Carton quantity: 1					
	A1. Top 1 pc.		A2. Top 1 pc.		B. Side Panel 1 pc.		C. Side Panel 1 pc.		D. Middle Panel 1 pc.		L. Frame Leg 1 pc.		M. Frame Leg 1 pc.
			3/4" Flat Head Screw 12 pcs. (+1 extra)										

Tools Required For Assembly : Phillips screwdriver

Tools Recommended For Assembly : Level

Kitchen Island

IMPORTANT NOTE

Carefully remove all the parts from the carton and put them individually on a soft cloth to prevent scratches or other damages occurring to the parts.

We have taken great care in the design of this product and request that you carefully and strictly follow our assembly instructions to ensure a completed product as it was designed.

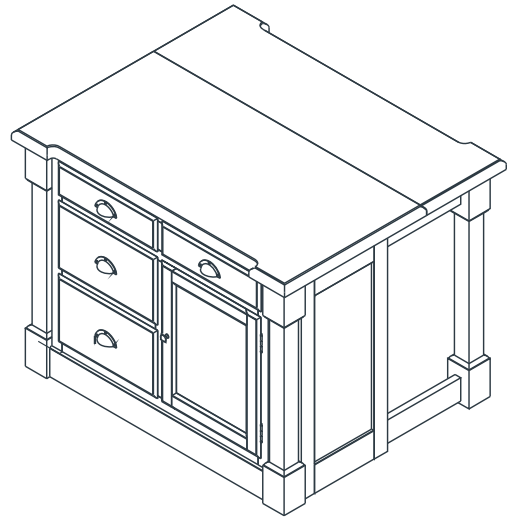

Part List

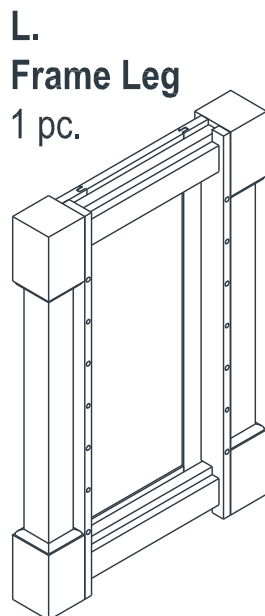

B.
Side Panel
1 pc.

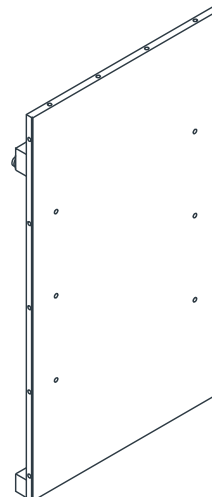
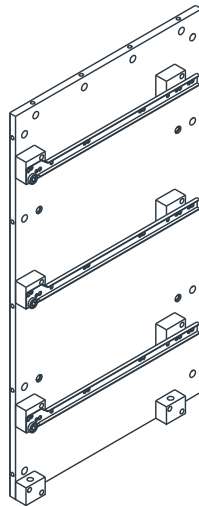

C.
Side Panel
1 pc.

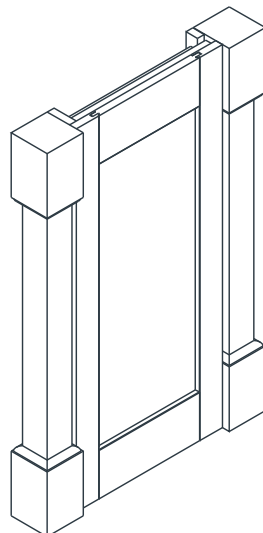

M.
Frame Leg
1 pc.

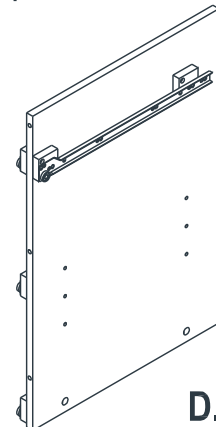

D.
Middle Panel
1 pc.

For assembly see instructions in carton

IMPORTANT

- * Please keep Hex Wrench in a safe place as you may need to tighten up the Head Cap Bolts in the future.
- * Do not tighten up all the screws until each part is properly assembled.
- * Use a soft cloth between these parts and the floor.
- * After assembly, item must be level to work properly. Use the included adjustable levellers to level.

STEP 1

Insert Cam Lock Screws into the pre-drilled holes of Side Panel (B) and (C), Front Part (E), Bottom (H) and Back Panel (I).

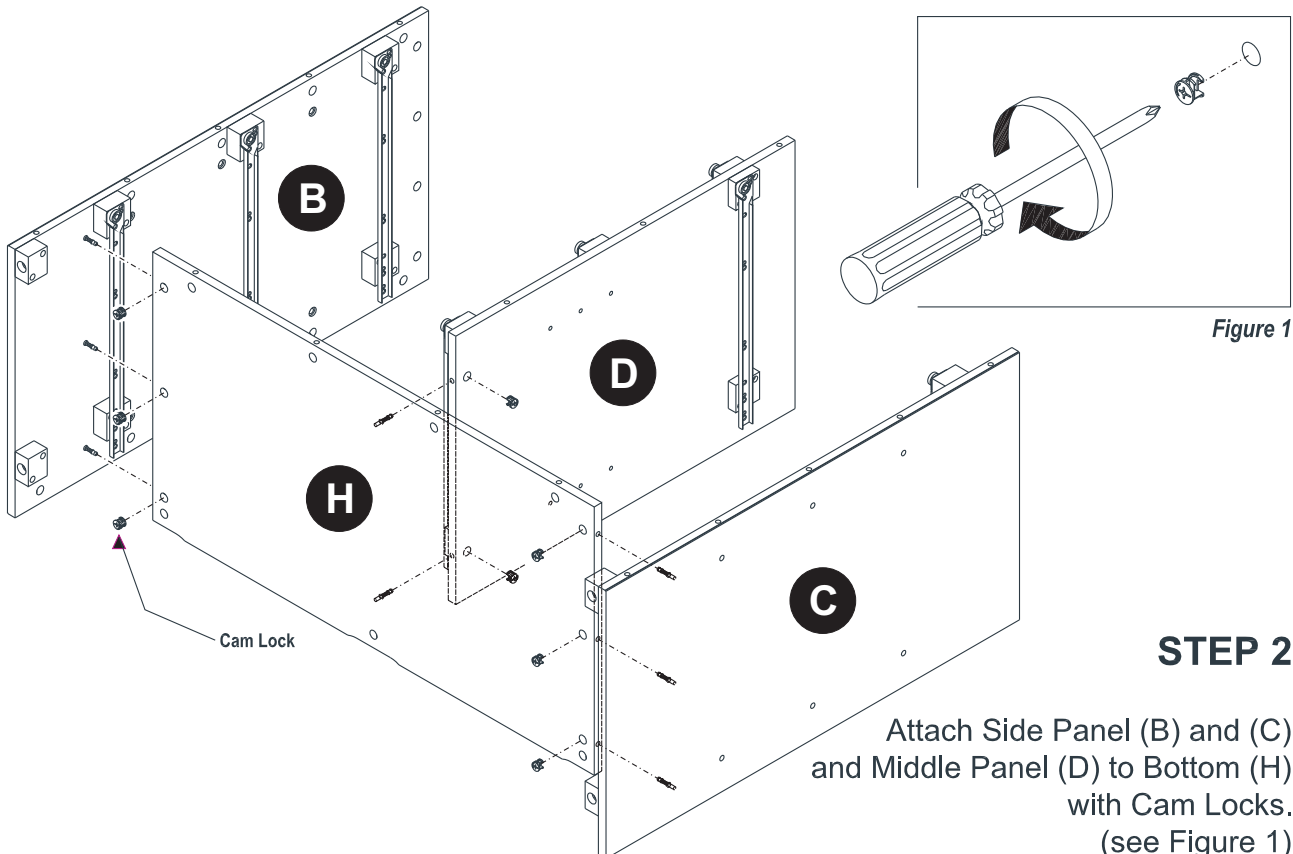
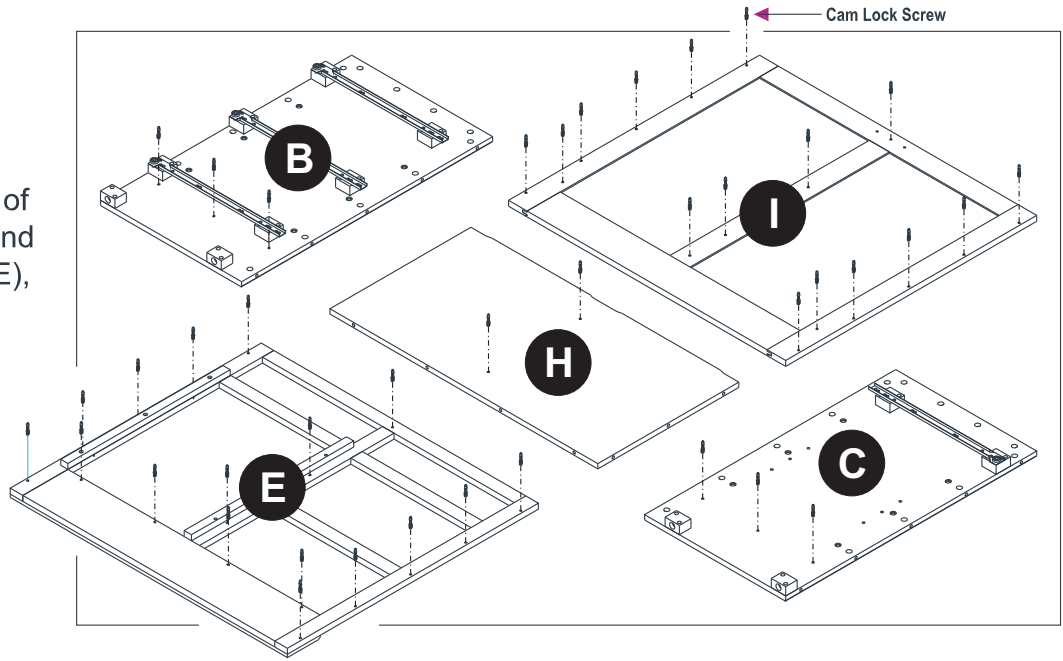

STEP 2

Attach Side Panel (B) and (C) and Middle Panel (D) to Bottom (H) with Cam Locks. (see Figure 1)

STEP 3

Attach Front Part (E) to unit using Cam Locks.

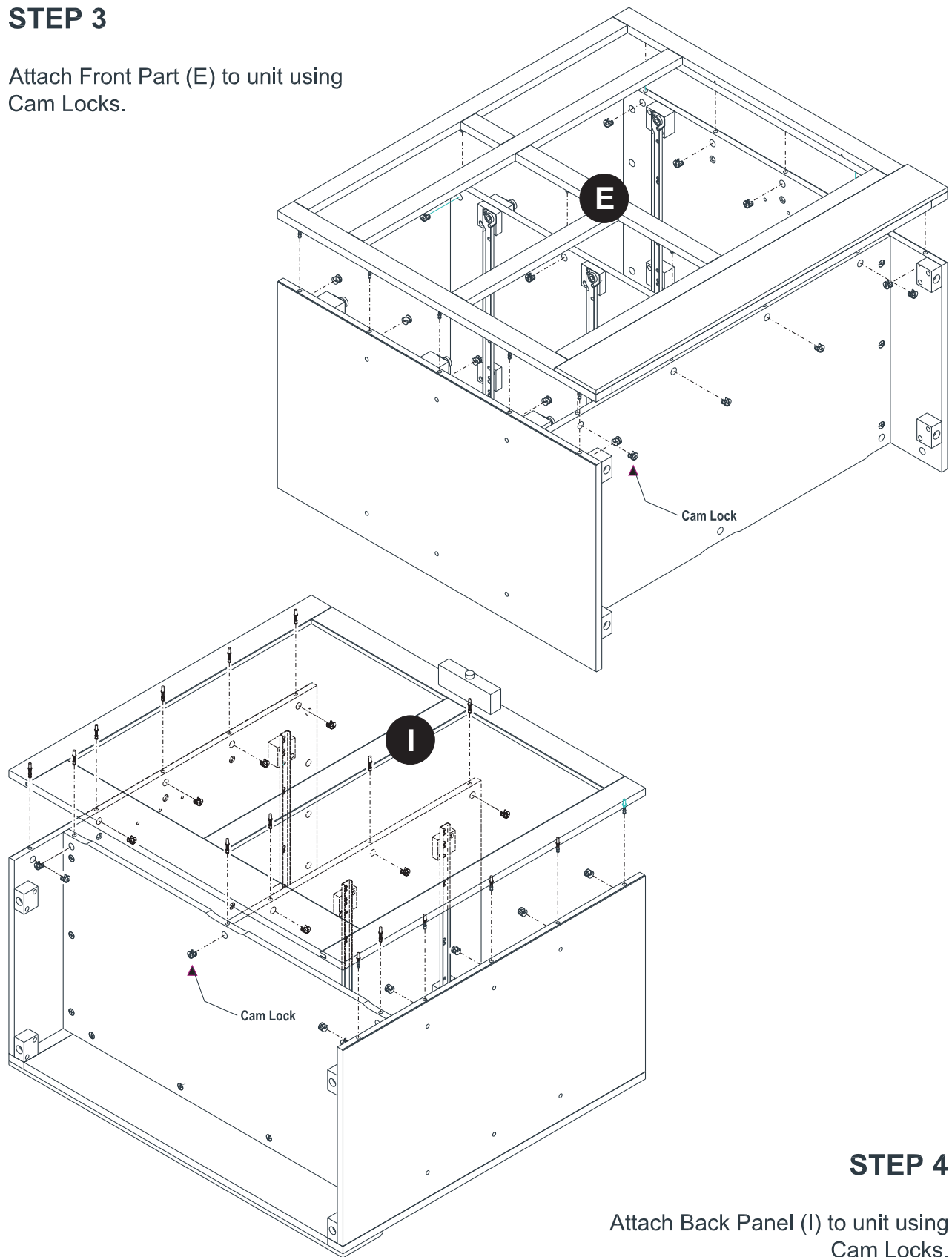

STEP 4

Attach Back Panel (I) to unit using Cam Locks.

STEP 5

Attach Frame Leg (L) and (M) to unit using Head Cap Bolts.

Tighten Head Cap bolts using Hex Wrench.
(see Figure 2)

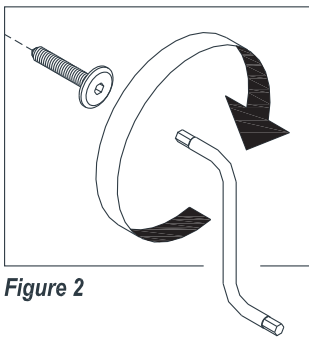
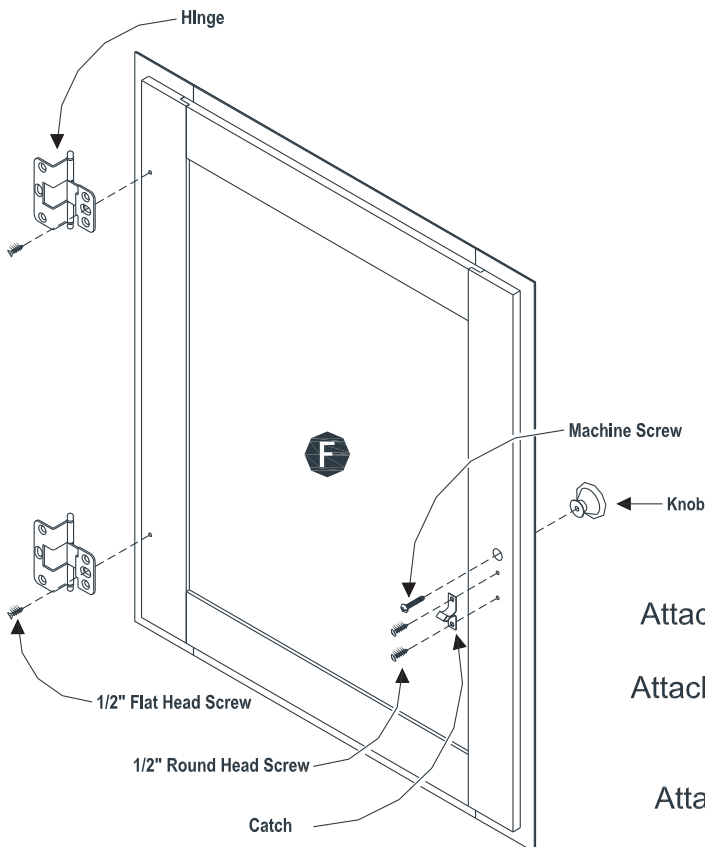
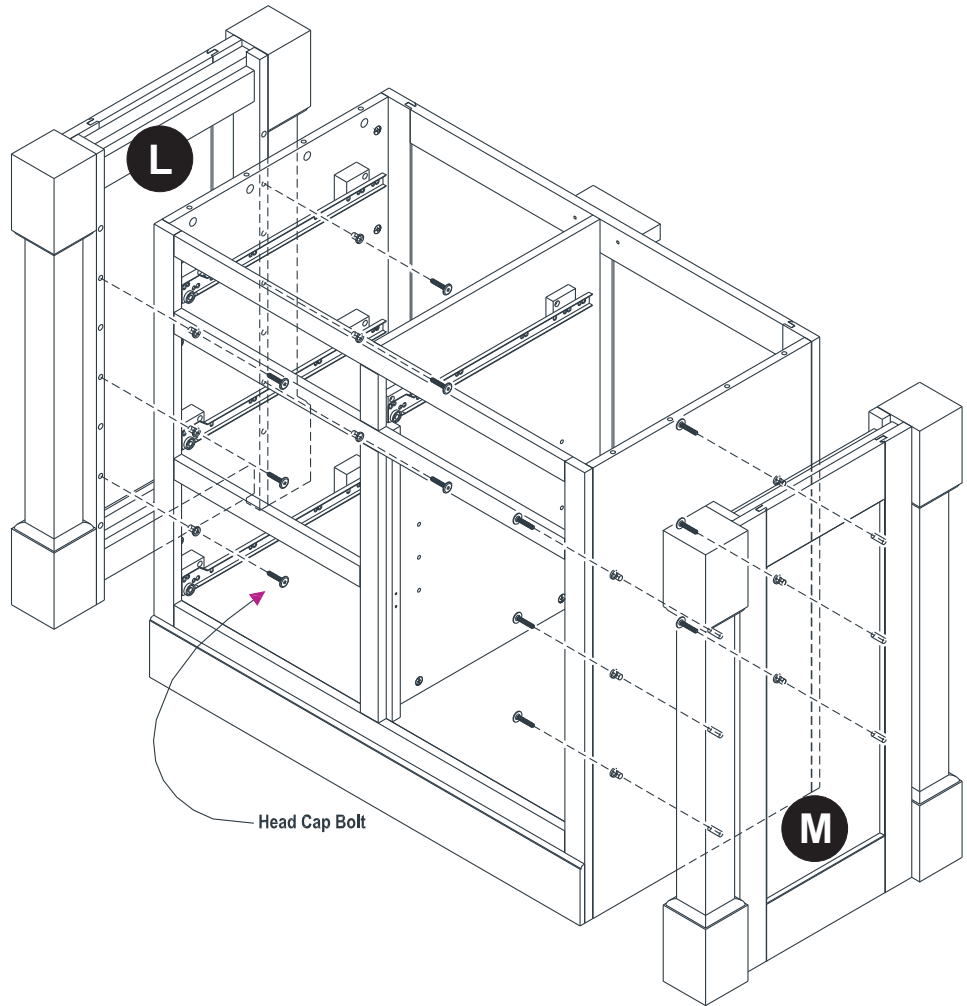

Figure 2



STEP 6

Attach Knob to Door (F) using Machine Screws.

Attach Catch to Door (F) using 1/2" Round Head Screws.

Attach Hinges to Door (F) using 1/2" Flat Head Screws into the oval hole of Hinge.

STEP 7

Attach Catch with Double Roller to unit using 1/2" Round Head Screws.

Attach Door (F) to unit using 1/2" Flat Head Screws into the oval hole of Hinges.

Use the oval hole of Hinges at the Door to adjust the Door left and right.
(see Figure 3)

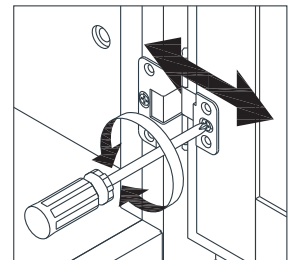
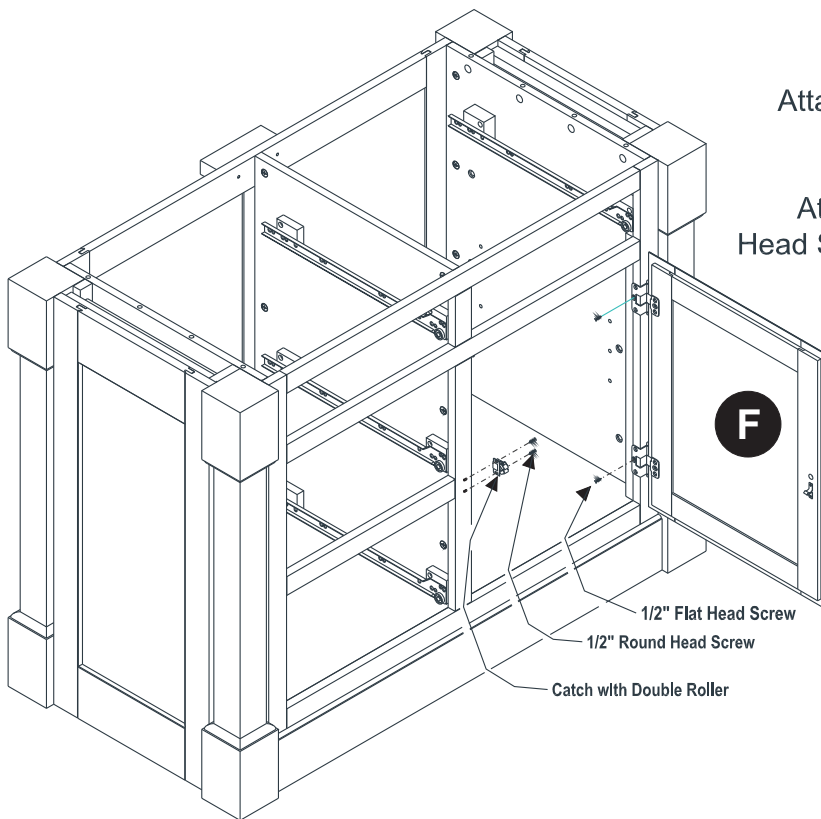

Figure 3

Use the oval hole of Hinges at the unit to adjust the Door up and down.
(see Figure 4)

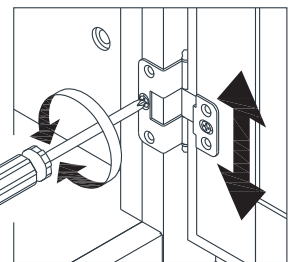
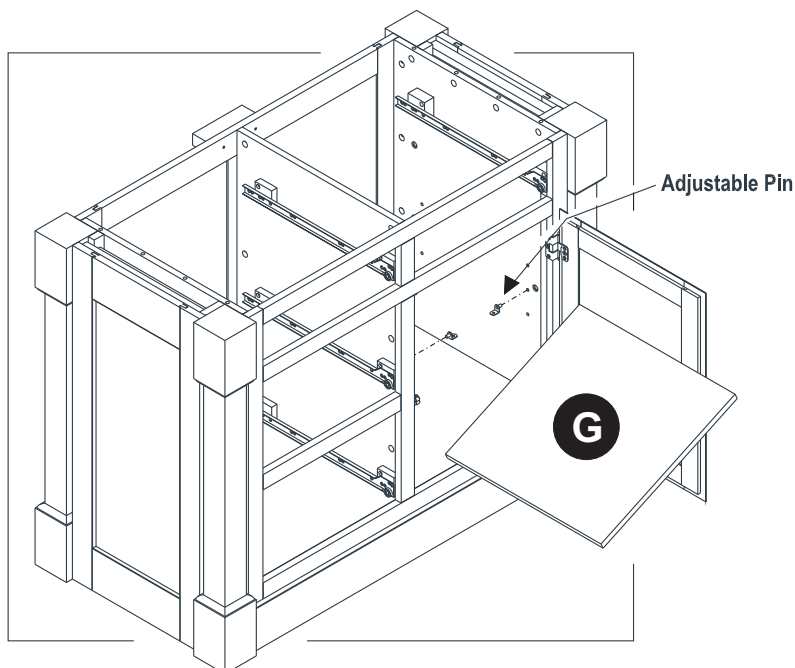

Figure 4

After adjustment, attach door using 1/2" Flat Head Screws through round holes of Hinges.
(see Figure 5)

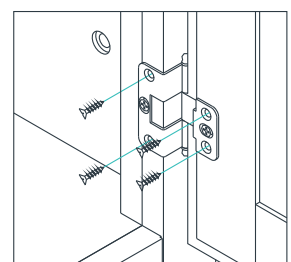
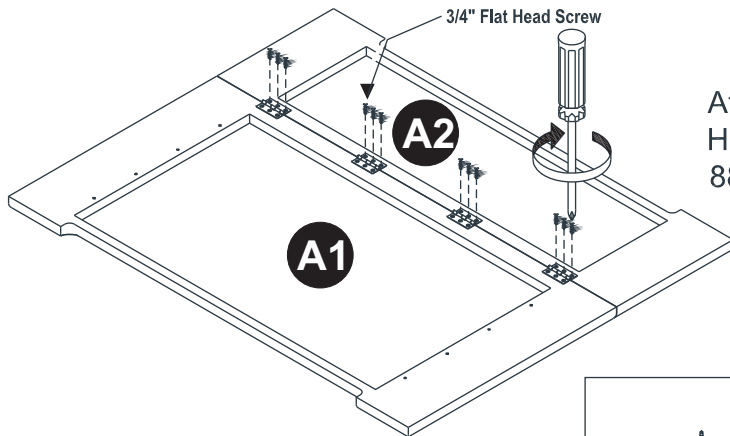

Figure 5

STEP 8

Insert Adjustable Pins into side panels and middle panel at the desired level. Slide Shelf (G) into position.



STEP 9

Attach Top (A1) to Top (A2) using 3/4" Flat Head Screws (Hardware included in carton 88 5520 941 for Wood Top or 88 5520 944 for Granite Top).

STEP 10

Insert Cam Lock Screws into the pre-drilled holes of Top Unit (A).

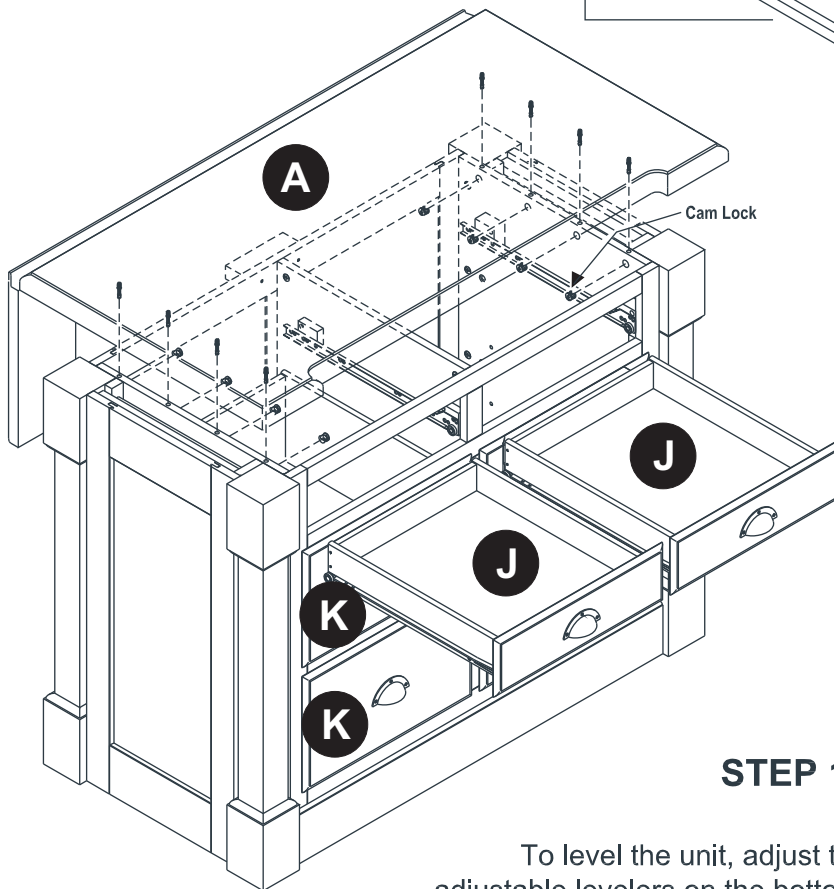
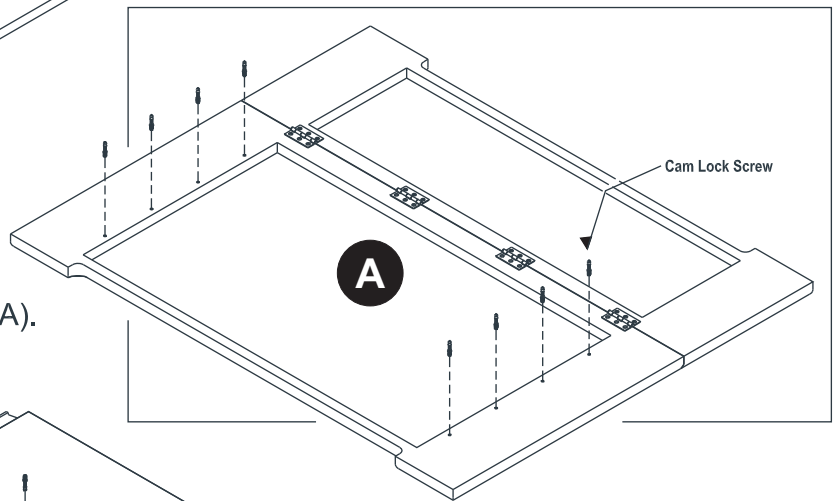

STEP 11

Place Top (A) onto the unit, using Cam Locks.

Slide Drawers (J) and (K) into place.

STEP 12

To level the unit, adjust the adjustable levelers on the bottom.

Note: Unit must be level to work properly.

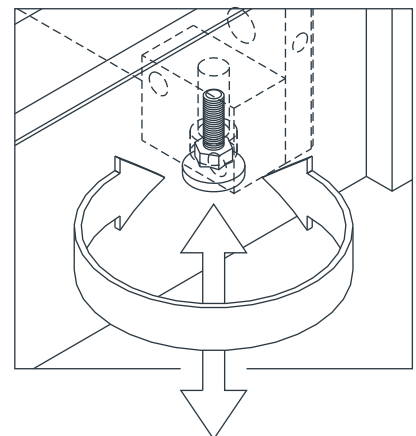

STEP 13

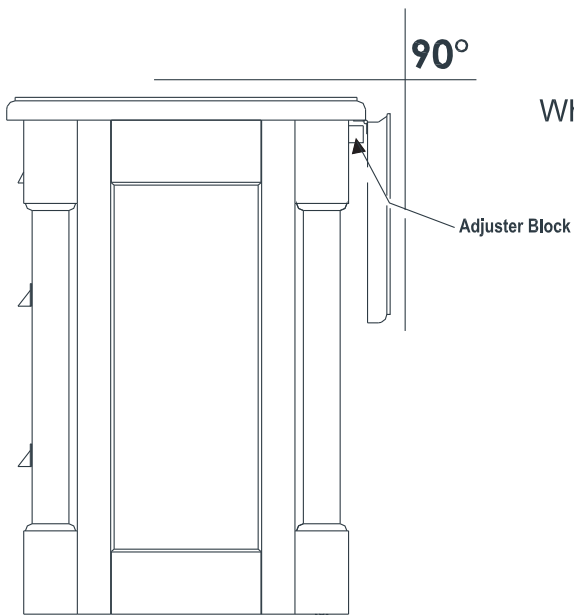

When Leaf Top is down, it should be oriented vertically.

If it is not vertical and adjustment is desired, turn the adjuster on the adjuster block on Back Panel (I). (see Figure 6)

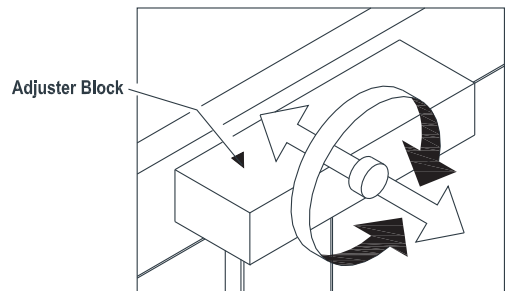
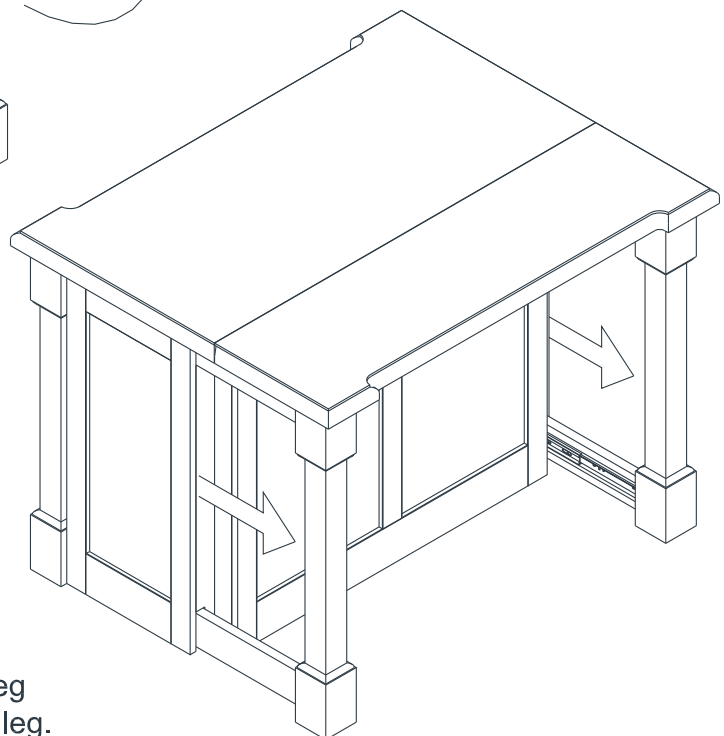
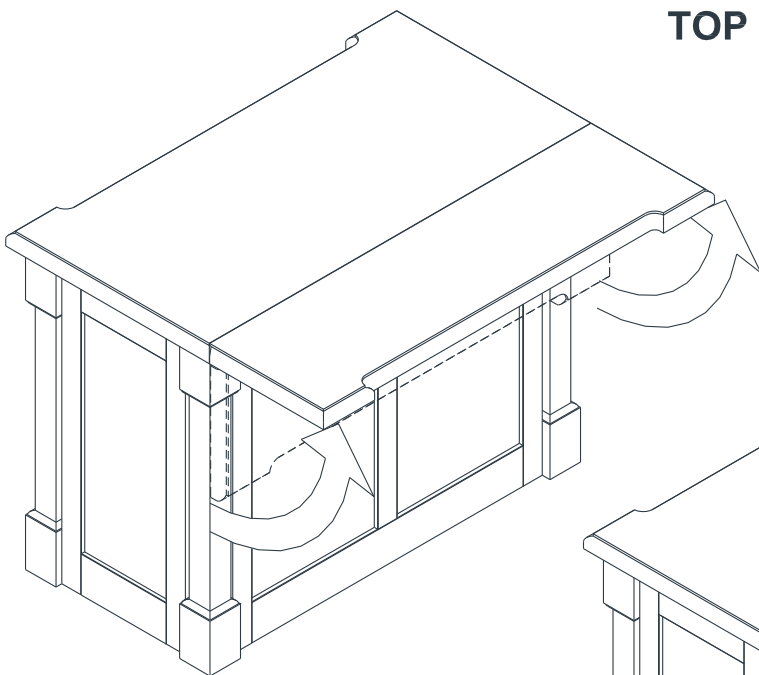

Figure 6

TOP EXTENSION INSTRUCTIONS

STEP 1

Lift up the Leaf Top.



STEP 2

Holding the Leaf Top up, pull out a back leg from the unit; then pull out the other back leg.

Drawer (J)

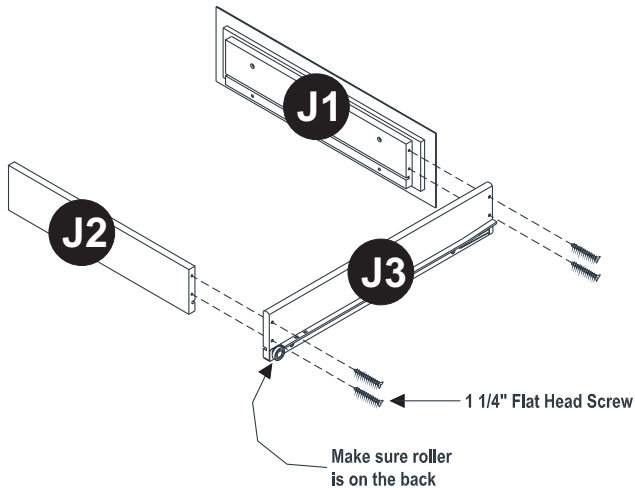

STEP 1

Attach Side Part (J3) to Front Part (J1) and Back Part (J2) using a Phillips screwdriver and 1 1/4" Flat Head Screws.

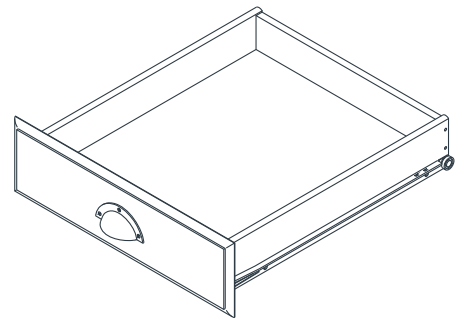

STEP 2

Insert Base Part (J5) into the groove.

Attach Side Part (J4) to Front Part (J1) and Back Part (J2) using a Phillips screwdriver and 1 1/4" Flat Head Screws.

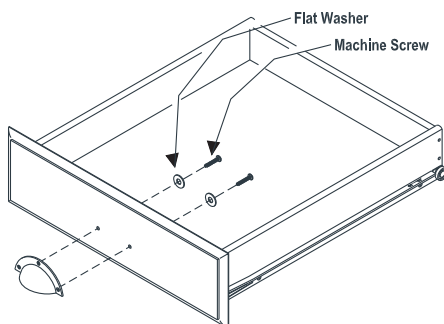
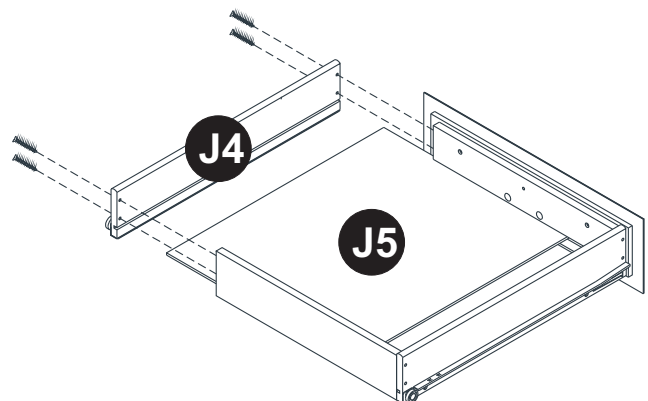

STEP 3

Attach Handles with Machine Screws and Flat Washers.

Part List

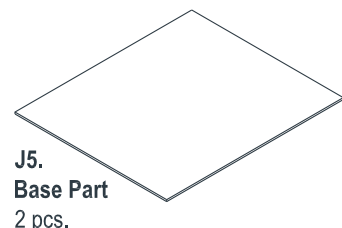
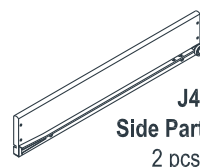
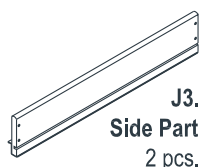
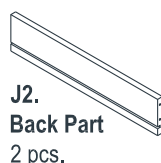
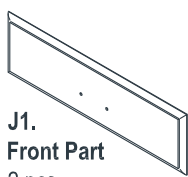

Drawer (K)

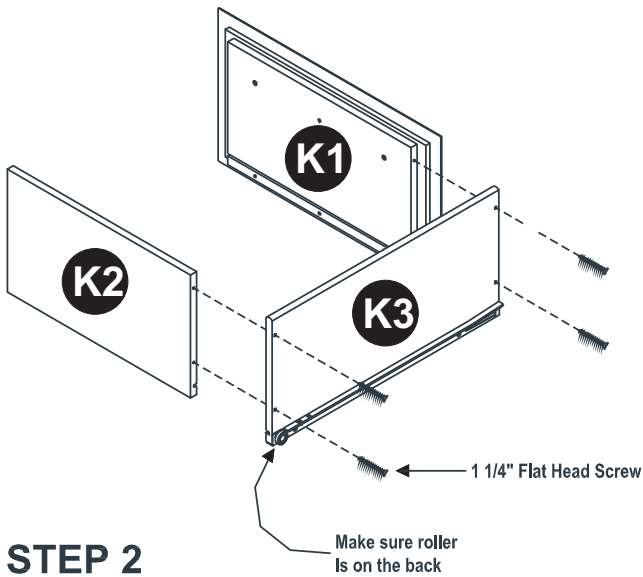

STEP 1

Attach Side Part (K3) to Front Part (K1) and Back Part (K2) using a Phillips screwdriver and 1 1/4" Flat Head Screws.

STEP 2

Insert Base Part (J5) into the groove.

Attach Side Part (K4) to Front Part (K1) and Back Part (K2) using a Phillips screwdriver and 1 1/4" Flat Head Screws.

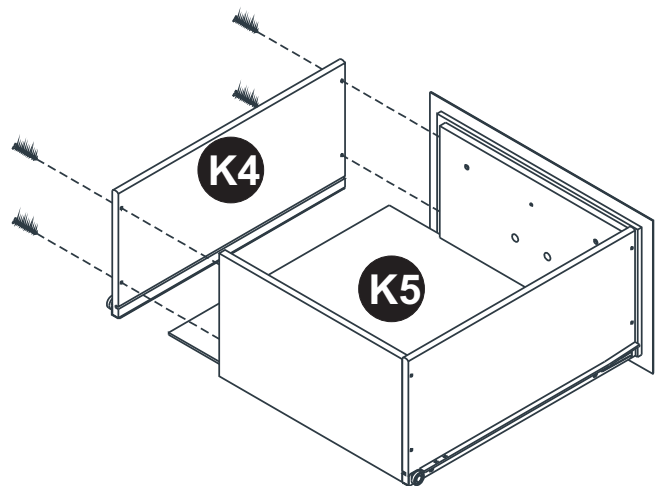
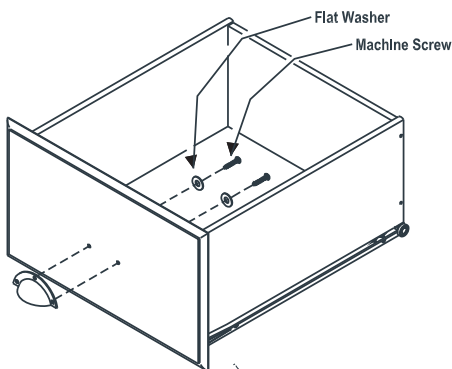

STEP 3

Attach Handles with Machine Screws and Flat Washers.

Part List

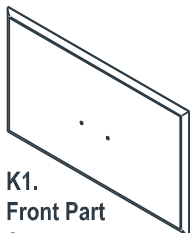

K1.
Front Part
2 pcs

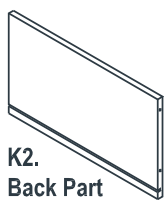

K2.
Back Part
2 pcs.

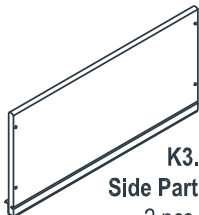

K3.
Side Part
2 pcs.

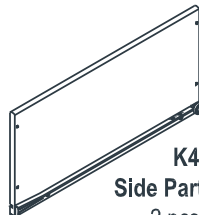

K4.
Side Part
2 pcs.

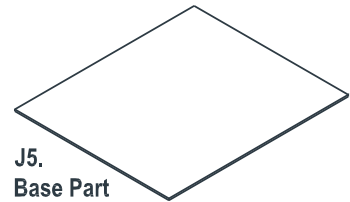

J5.
Base Part
2 pcs.

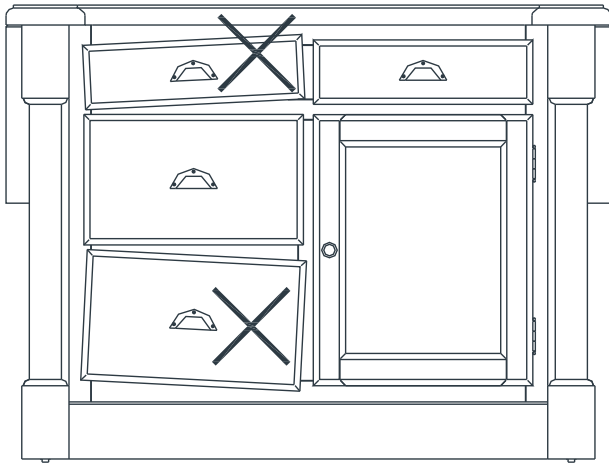

I. IF A DRAWER DOES NOT ALIGN

STEP 1

Loosen slightly the upper screws.

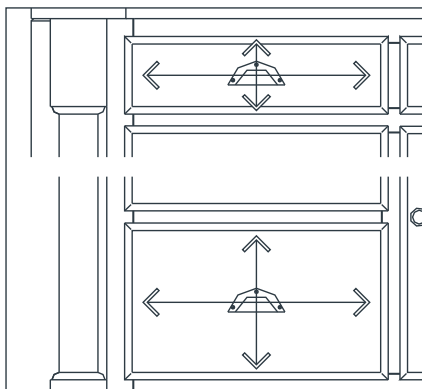
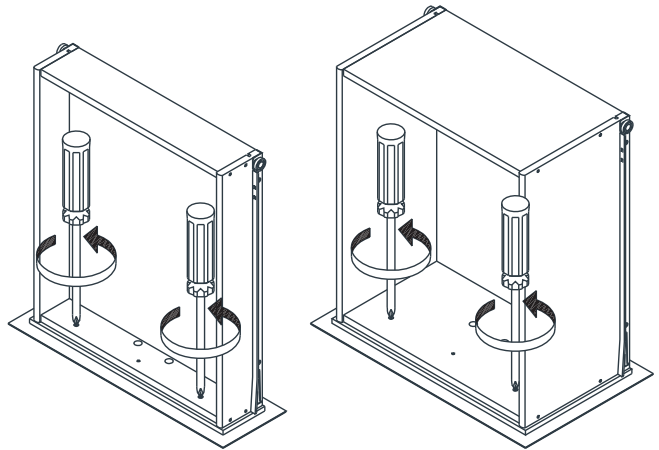

STEP 2

Insert the drawer into the main body, then adjust the drawer front panel left or right and up or down, until the drawer gaps look proportional.

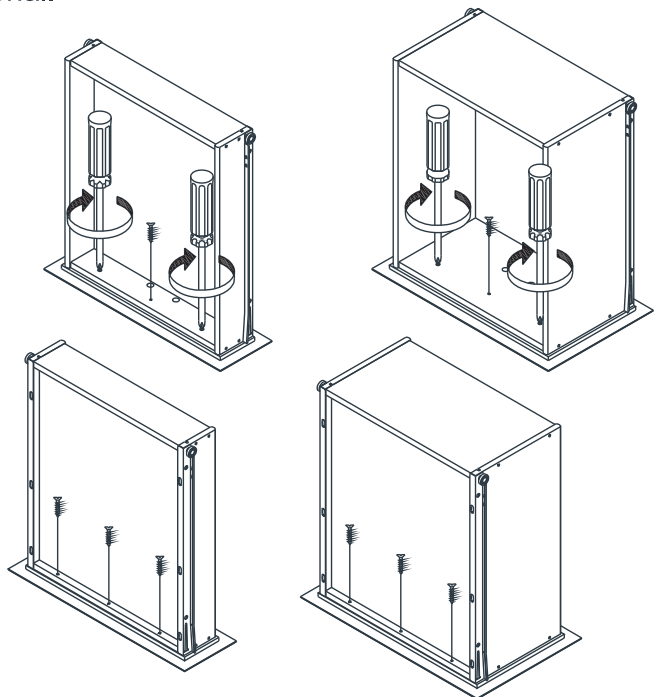

II. IF A DRAWER ALREADY ALIGNS

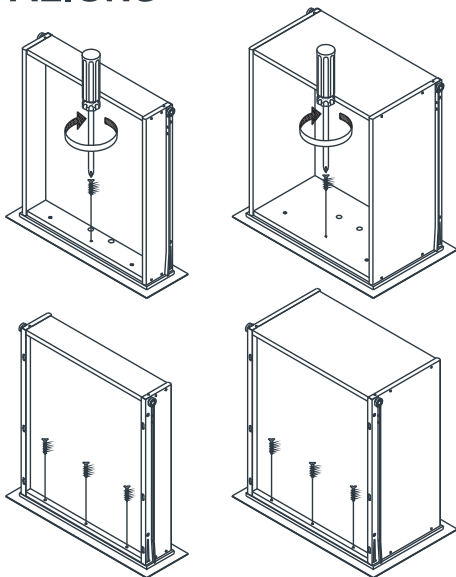

Pull out drawer slowly. Lock the drawer front panel into position with 3/4" Flat Head Screws.

STEP 3

Pull the drawer open slowly and tighten the upper screws. Make sure the front panel does not move and lock the drawer front panel into position with 3/4" Flat Head Screws.