

ASSEMBLY INSTRUCTION

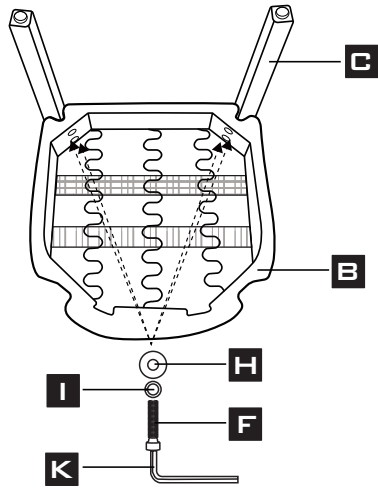

1

Put the screws in the holes, tight the screws, but not too tight, 90% is ok

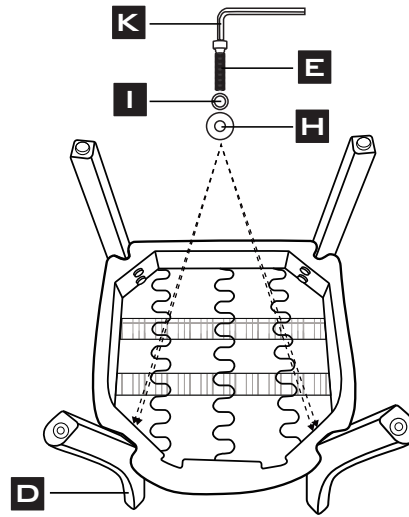

2

Put the screws in the holes, tight the screws, but not too tight, 90% is ok

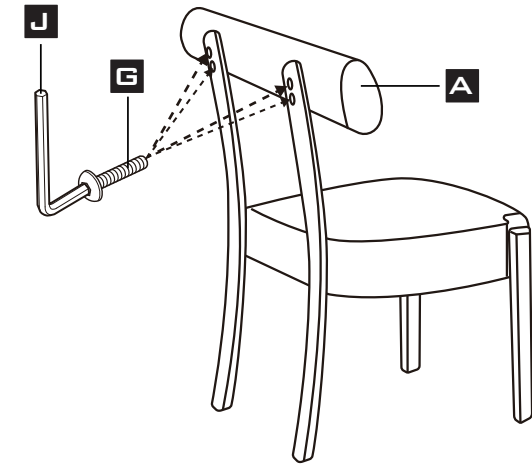





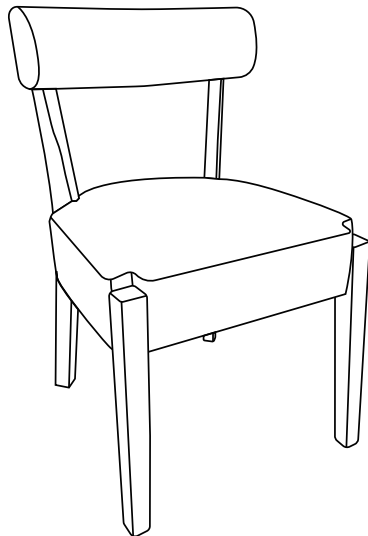

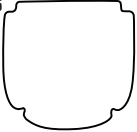
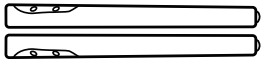

3

Stand the chair upright & ensure it is level before tightening all screws. Then tight all the screws to 100% Then Stick the black part on the seat



4

A x2 PCS 	B x2 PCS 
C x4 PCS 	D x4 PCS 
E x10 PCS  (M8*45)	F x10 PCS  (M8*65)
H x18 PCS 	I x18 PCS 
J x2 PCS  M6	K x2 PCS  M8

Please find hardware pack inside the dust cover underneath seat cushion