







ASSEMBLY INSTRUCTION













Thank you for purchasing this quality product. Be sure to check all packing material carefully for small parts which may have come loose inside the carton during shipment. Separate, identify and count all parts and hardware. Compare with the parts list to be sure all parts are present.

"DO NOT TIGHTEN SCREWS UNTIL COMPLETELY ASSEMBLED"

IMPORTANT:

PLEASE READ INSTRUCTION BEFORE STARTING THE ASSEMBLY

| HARDWARE LIST | | | | |
|---------------|---------------|---|-----------|-------|
| ITEM | DESCRIPTION | DRAWING | SIZE | QTY |
| A | JCBB SCREW |  | M8 X 20MM | 16PCS |
| B | JCBC SCREW |  | M6 X 50MM | 20PCS |
| C | SPRING WASHER |  | M6 X 13MM | 16PCS |
| D | FLAT WASHER |  | M6 X 19MM | 4PCS |
| E | FLAT WASHER |  | M6 X 13MM | 12PCS |
| F | SCREW |  | M4 X 32MM | 16PCS |
| G | SCREW |  | M4 X 16MM | 24PCS |
| H | L - KEY |  | M4 X 65MM | 1PC |
| I | L - KEY |  | M5 X 65MM | 1PC |

| PART LIST | | | |
|-----------|--------------------|--|--------|
| ITEM | DESCRIPTION | DRAWING | QTY |
| 1 | BACK REST |  | 1PC |
| 2 | LEFT ARM |  | 1PC |
| 3 | RIGHT ARM |  | 1PC |
| 4 | FRONT SIDE RAIL |  | 1PC |
| 5 | BACK SIDE RAIL |  | 1PC |
| 6 | LEGS |  | 4PCS |
| 7 | DAYBED SLAT |  7PCS | 2 SETS |
| 8 | TRUNDLE FRONT RAIL |  | 1PC |
| 9 | TRUNDLE BACK RAIL |  | 1PC |
| 10 | TRUNDLE SIDE RAIL |  | 2PCS |
| 11 | SUPPORT SLAT |  | 3PCS |
| 12 | TRUNDLE SLAT |  5PCS | 2 SETS |
| 13 | CASTORS |  | 6PCS |

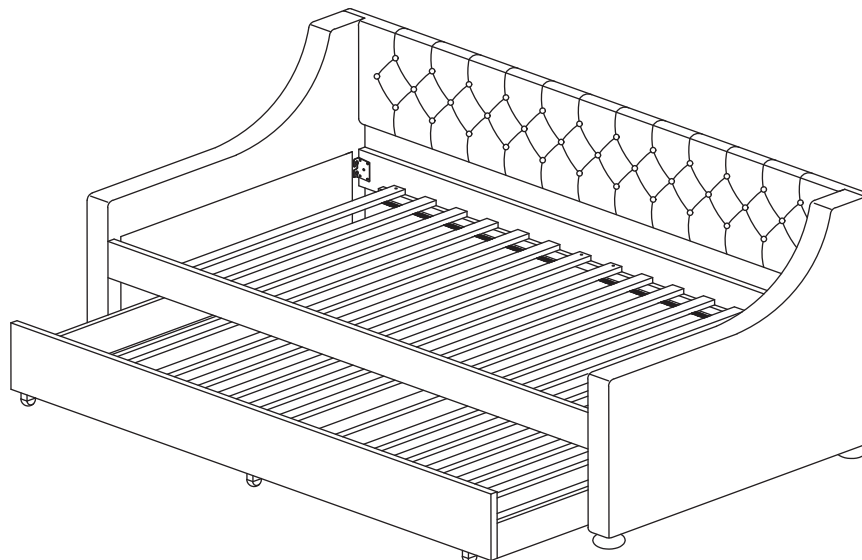

ASSEMBLY INSTRUCTION

STEP 1

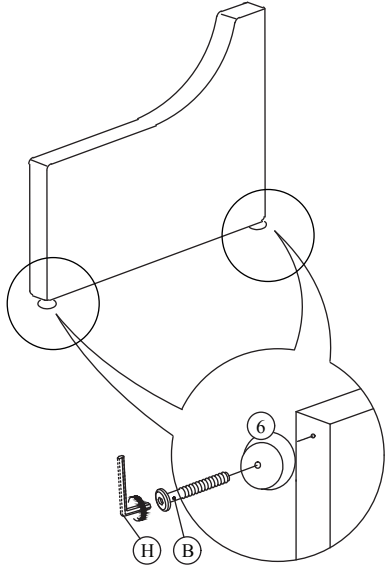

STEP 2

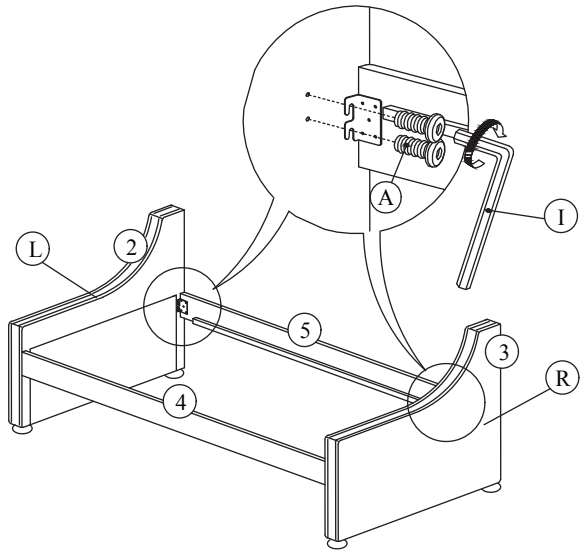

STEP 3

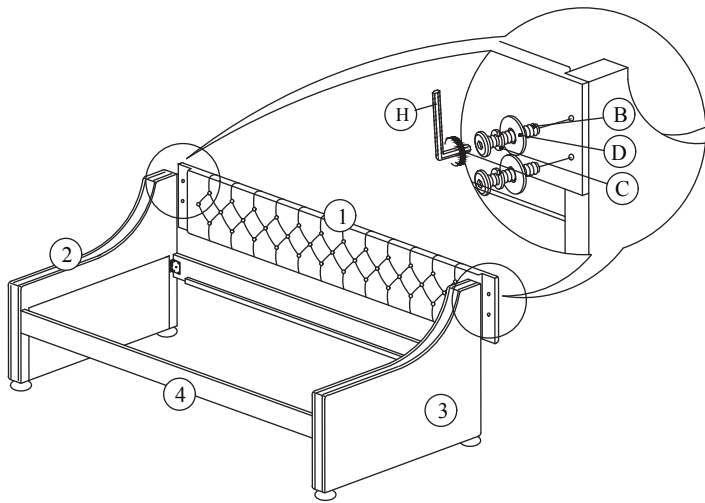

STEP 4

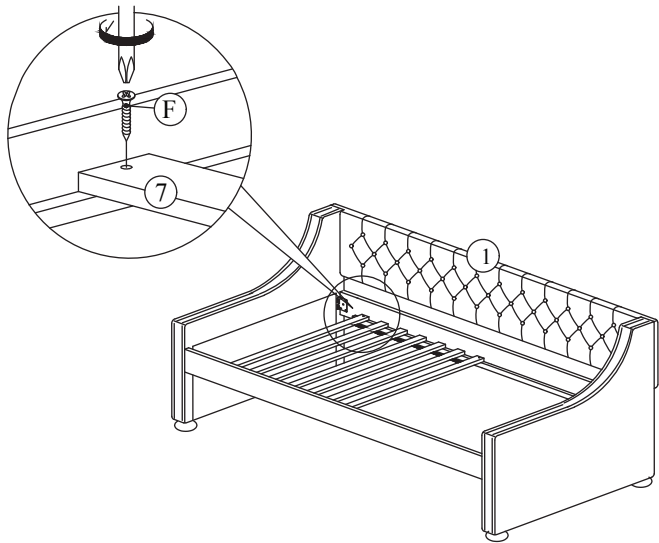

STEP 5

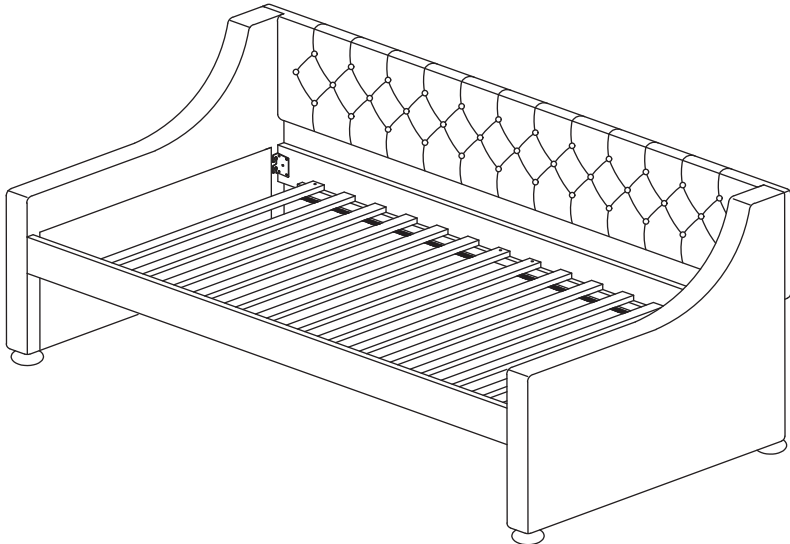

ASSEMBLY INSTRUCTION

STEP 6

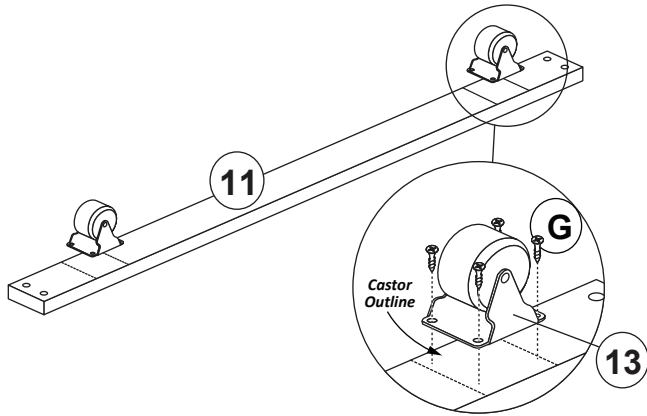

STEP 7

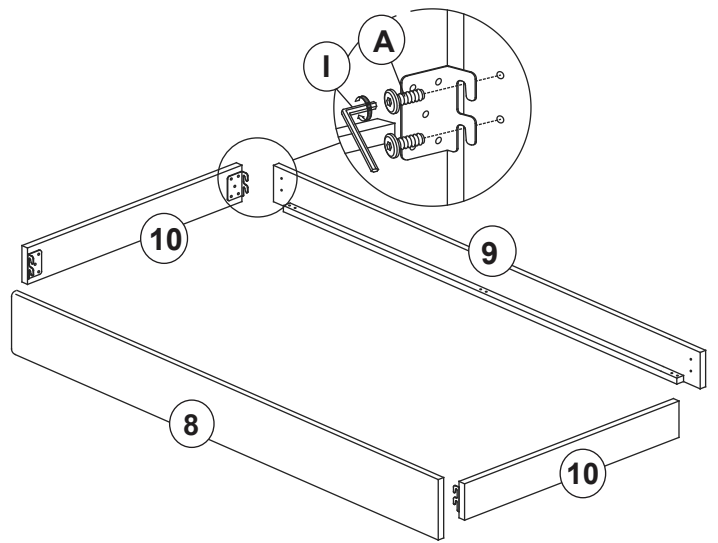

STEP 8

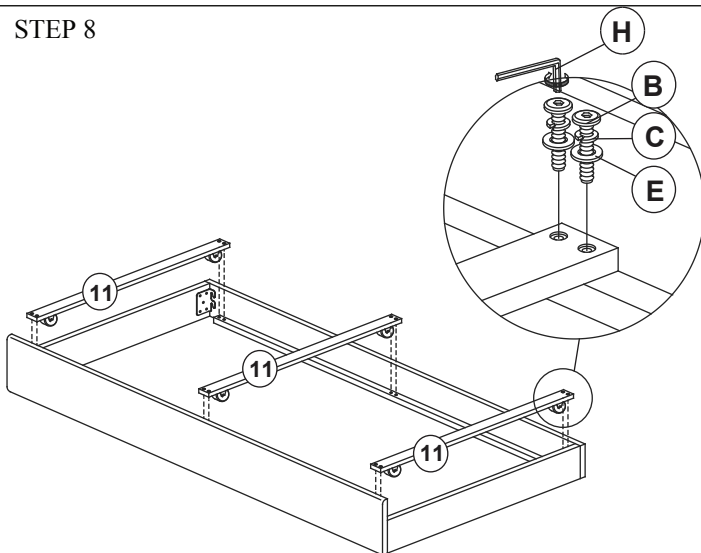

STEP 9

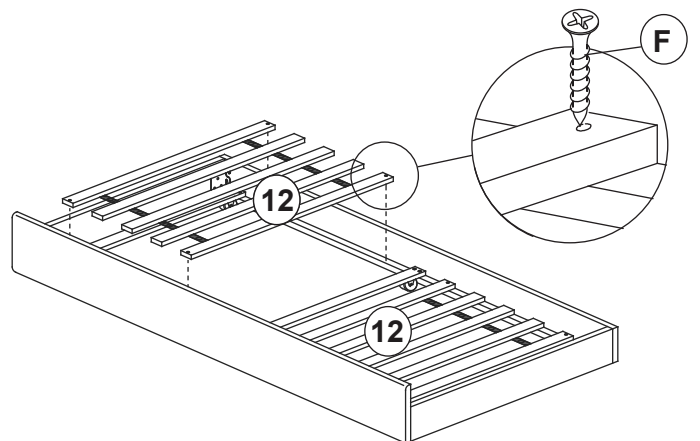

STEP 10

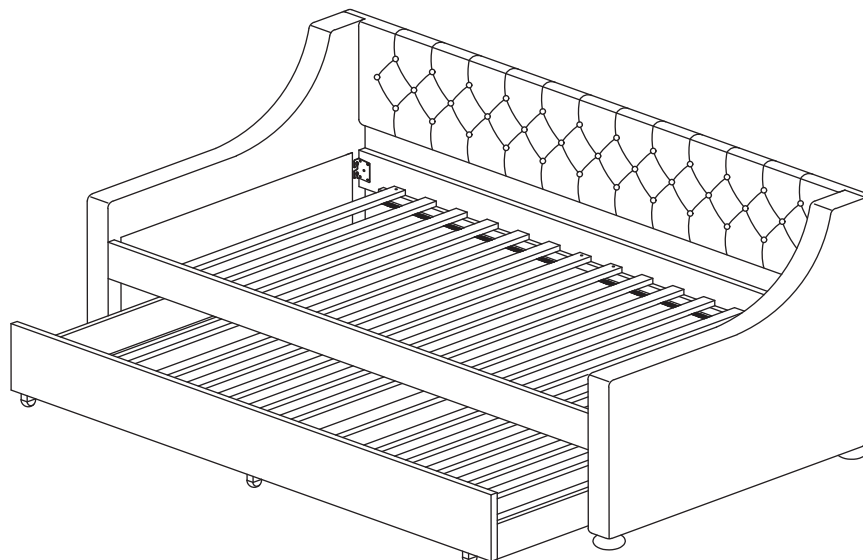

ASSEMBLY
COMPLETED