

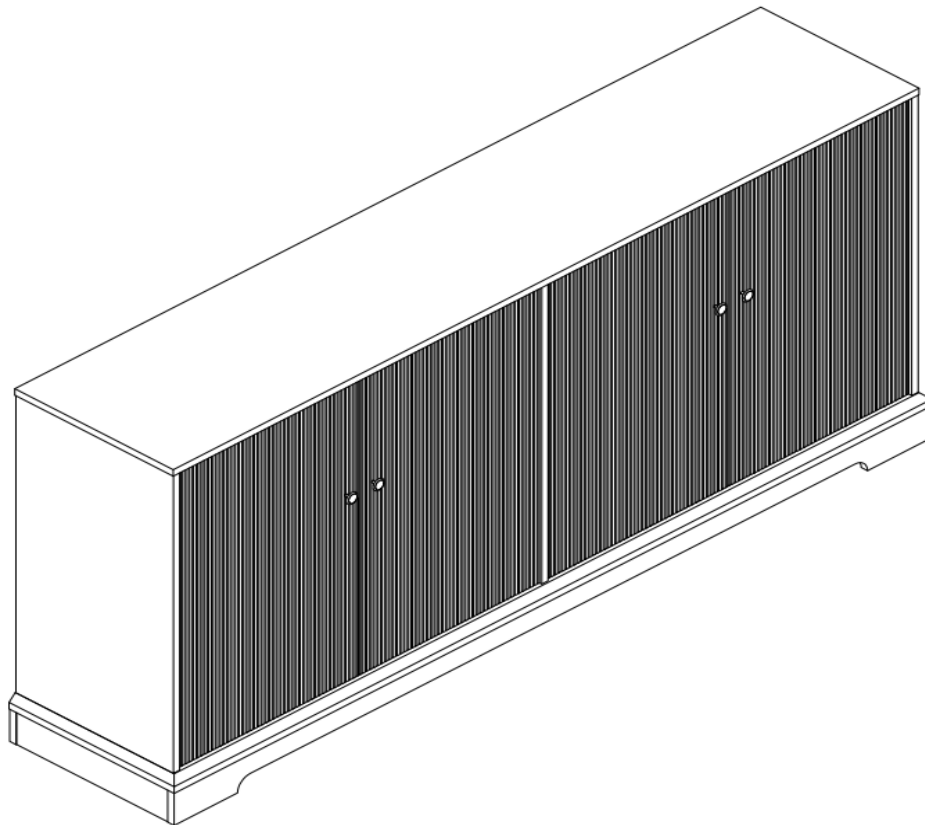













User Manual

ASSEMBLY INSTRUCTION















Parts List

NO.	Drawing	Dimension	QTY
1		1652*374*15mm	1
2		687*372*15mm	2
3		687*350*15mm	2
4		687*372*15mm	1
5		1680*390*30mm	1
6		391*334*15mm	8
7		403*348*4.5mm	4

NO.	Drawing	Dimension	QTY
8		403*348*4.5mm	4
9		1678*75*15mm	2
10		358*75*15mm	2
11		681*396*18mm	1
12		681*396*18mm	1
13		681*396*18mm	1
14		681*396*18mm	1

Hardware Fitting

NO.	Drawing	QTY
A		40
B		40
C		4
D		48
E	 3.0*14mm	48
F	 3.5*14mm	56
G	 6*22mm	1

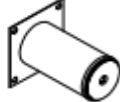
NO.	Drawing	QTY
H		32
I		8
J	 L393mm	4
K	 4*22mm	4
L	 3.5*35mm 3.5*14mm	2
M		2



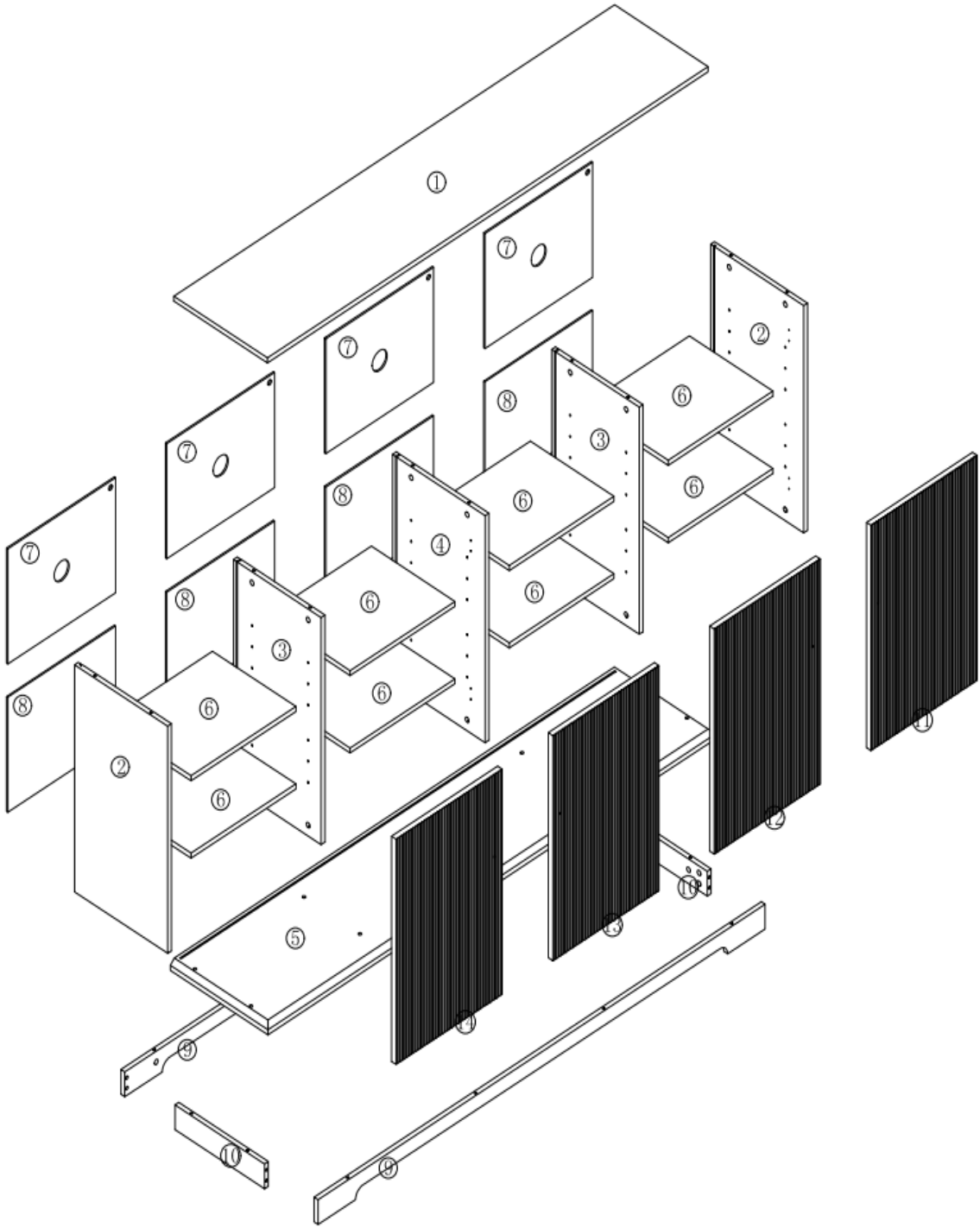

Cam Coupling Using Methods



Step1.

Connect the cam coupling A as directed in the assembly instructions using hand.



Step2.

Screw the cam coupling A as directed in the assembly instructions.

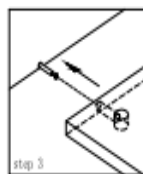

Step3.

Push the cam coupling A into the entry hole.

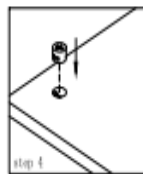

Step4.

Insert the cam coupling B as shown in the instructions.



Step5.

Turn the cam coupling B clockwise with a screwdriver



Step6.

Put on Beautycam.

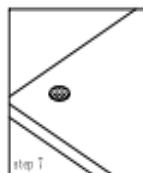



Step7.

Finished.

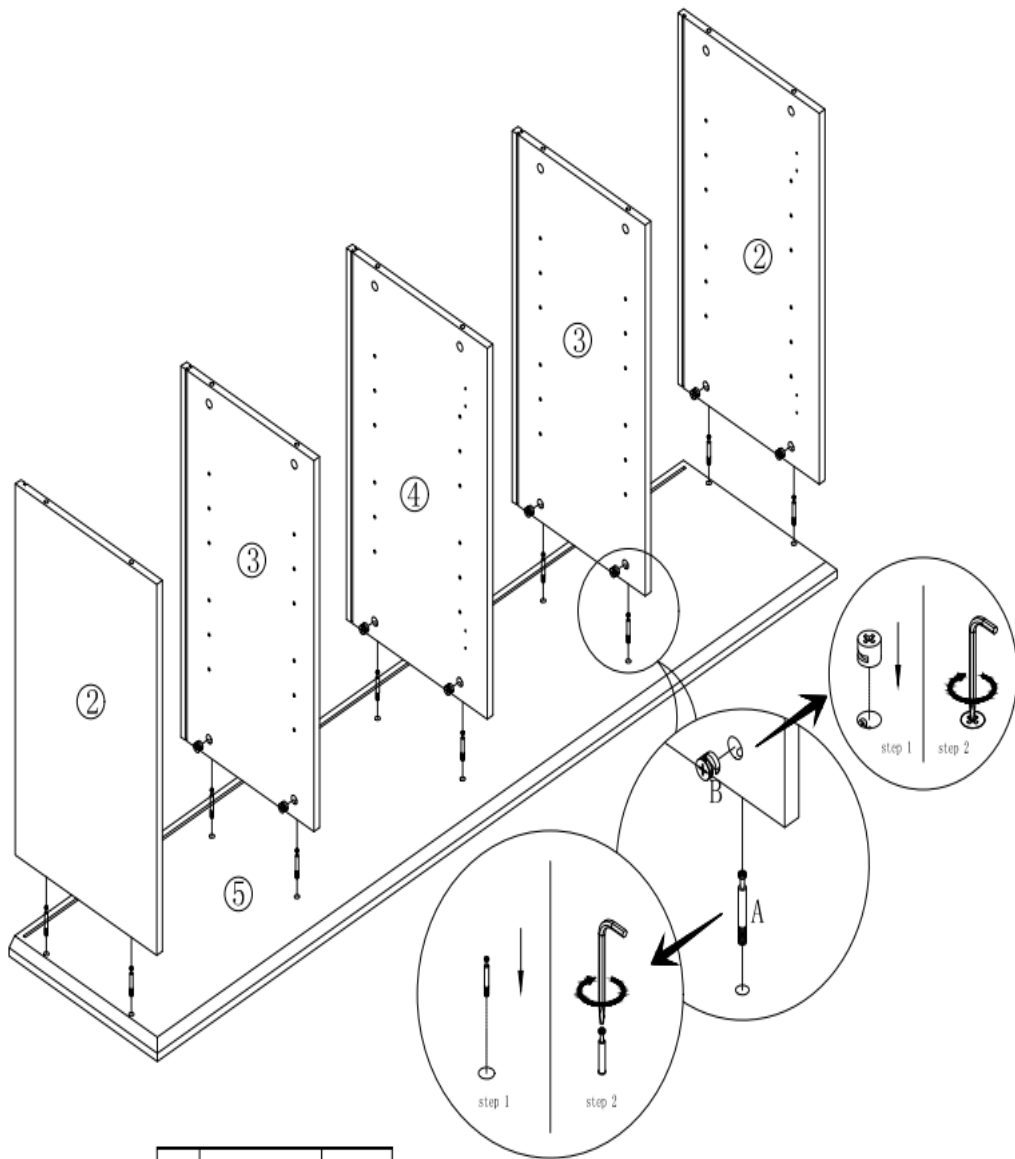
You should feel a click when the camlock is locked in place.
The joint is now secure.



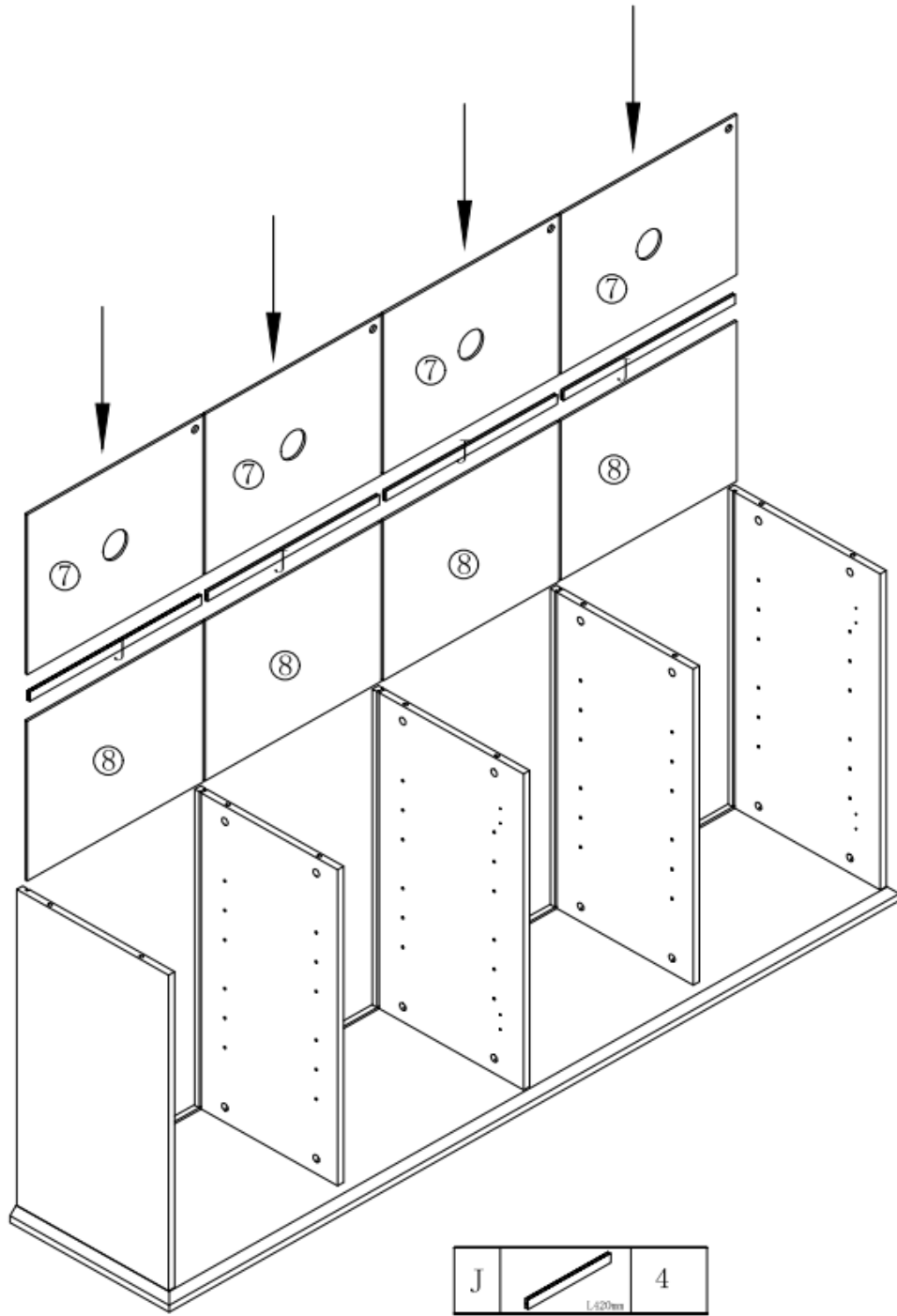

A		10
B		10

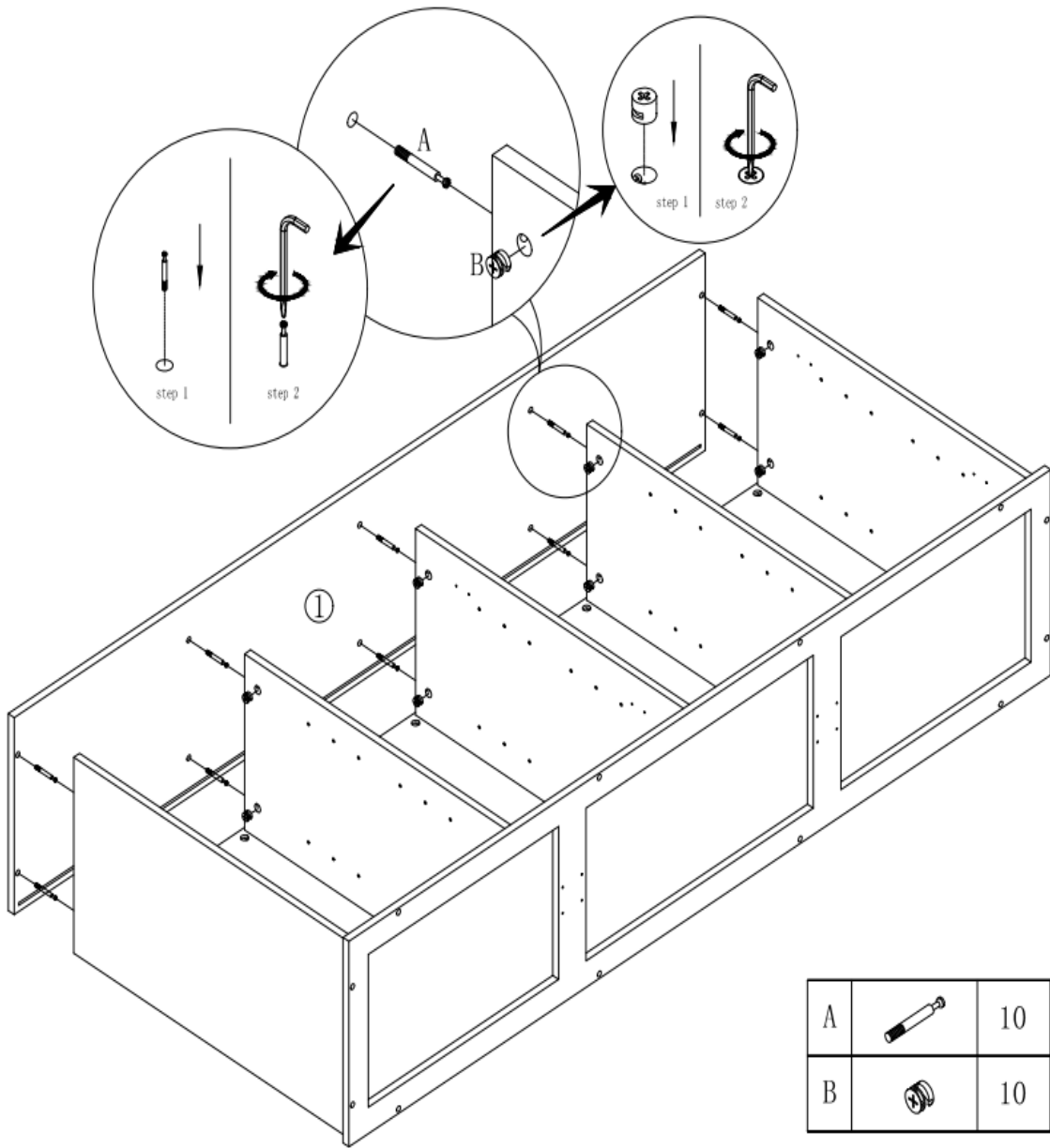

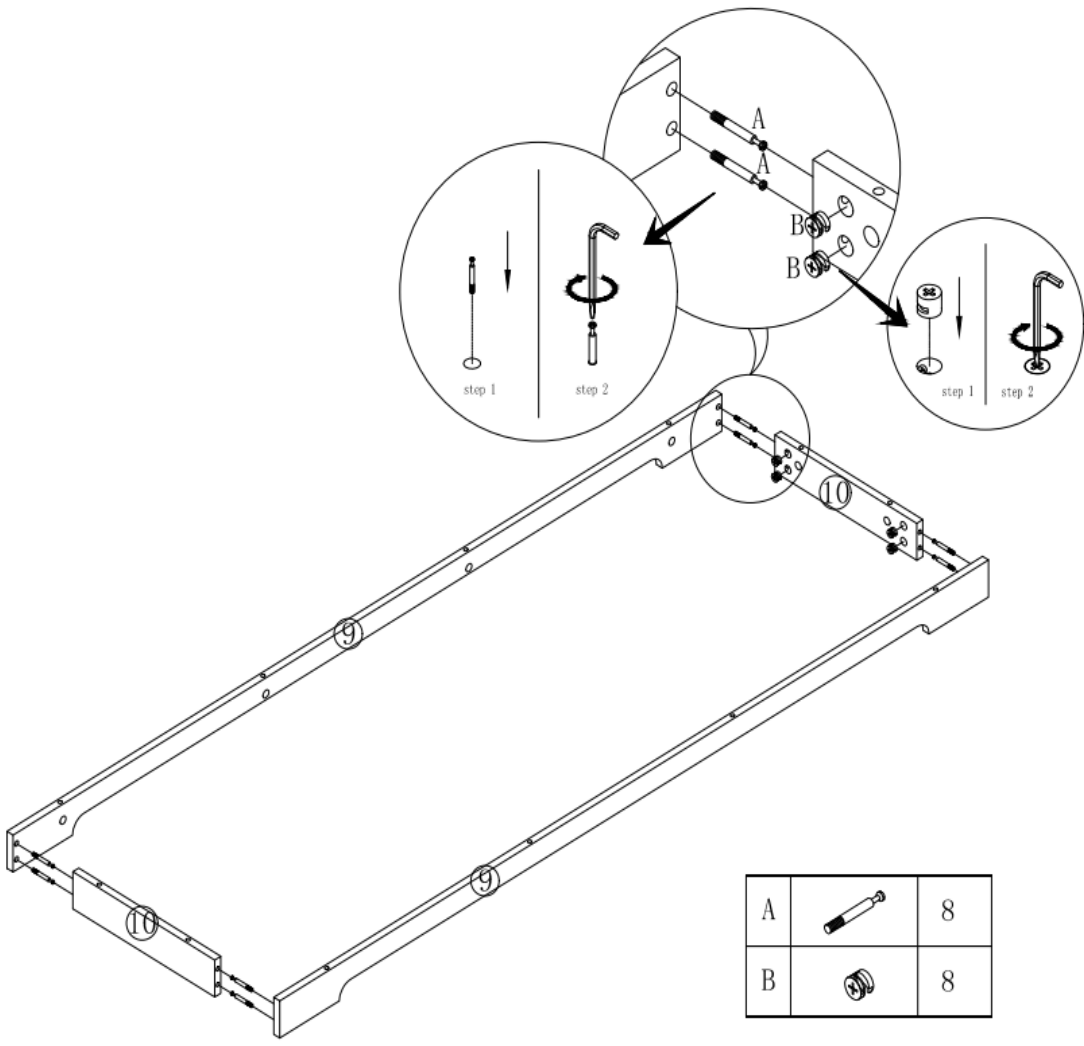

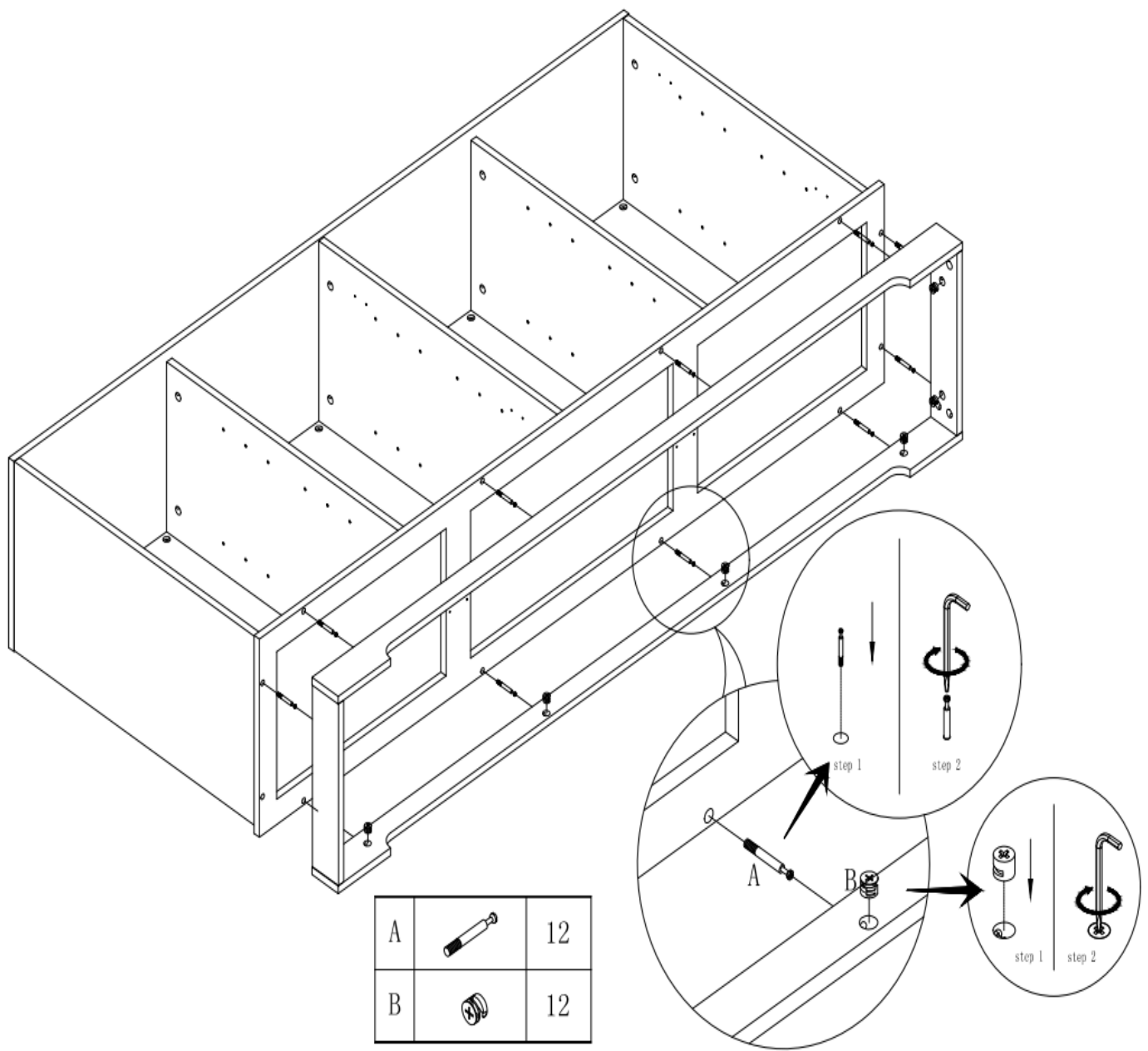



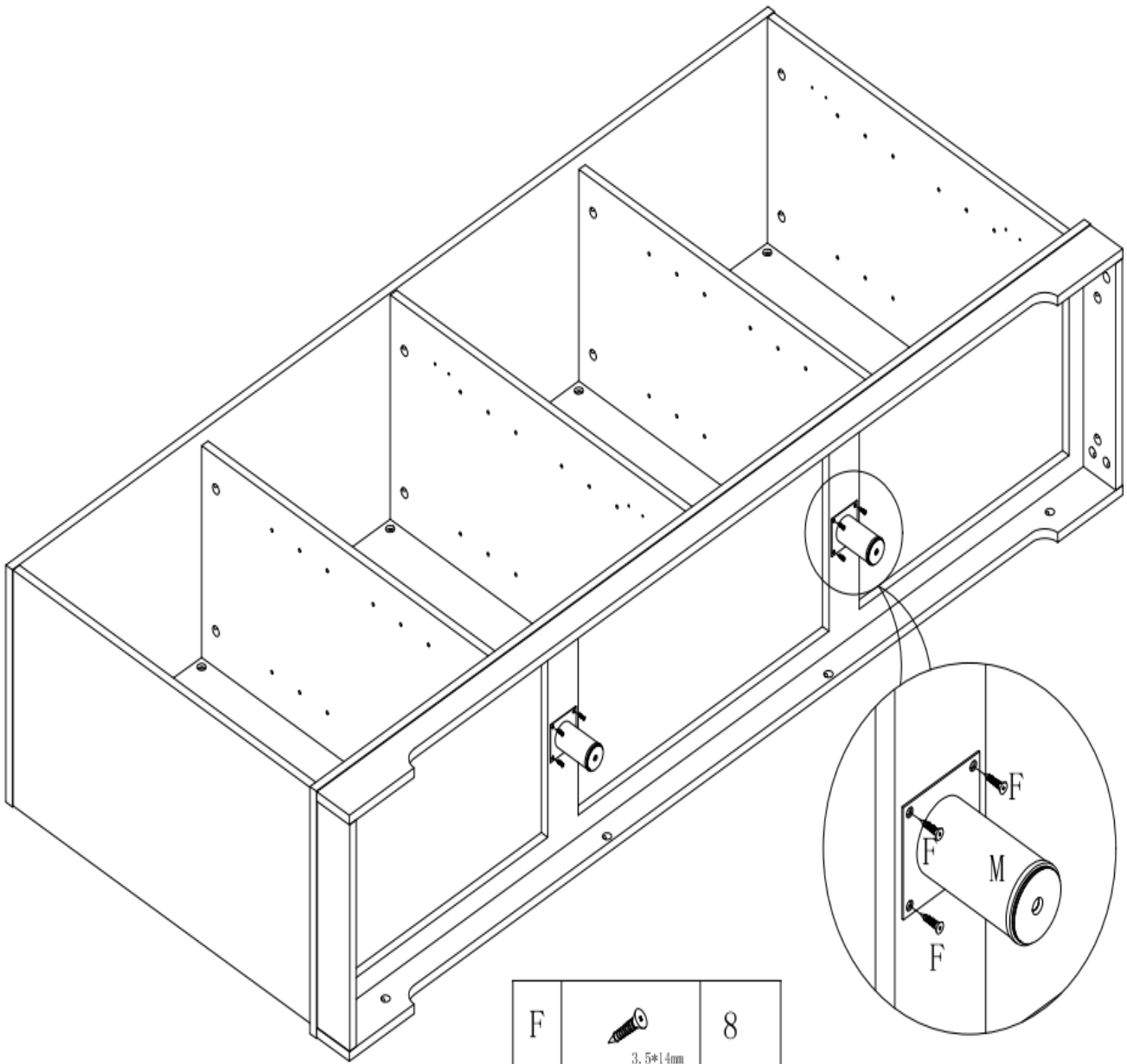

A		12
B		12



F	 3.5*14mm	8
M		2

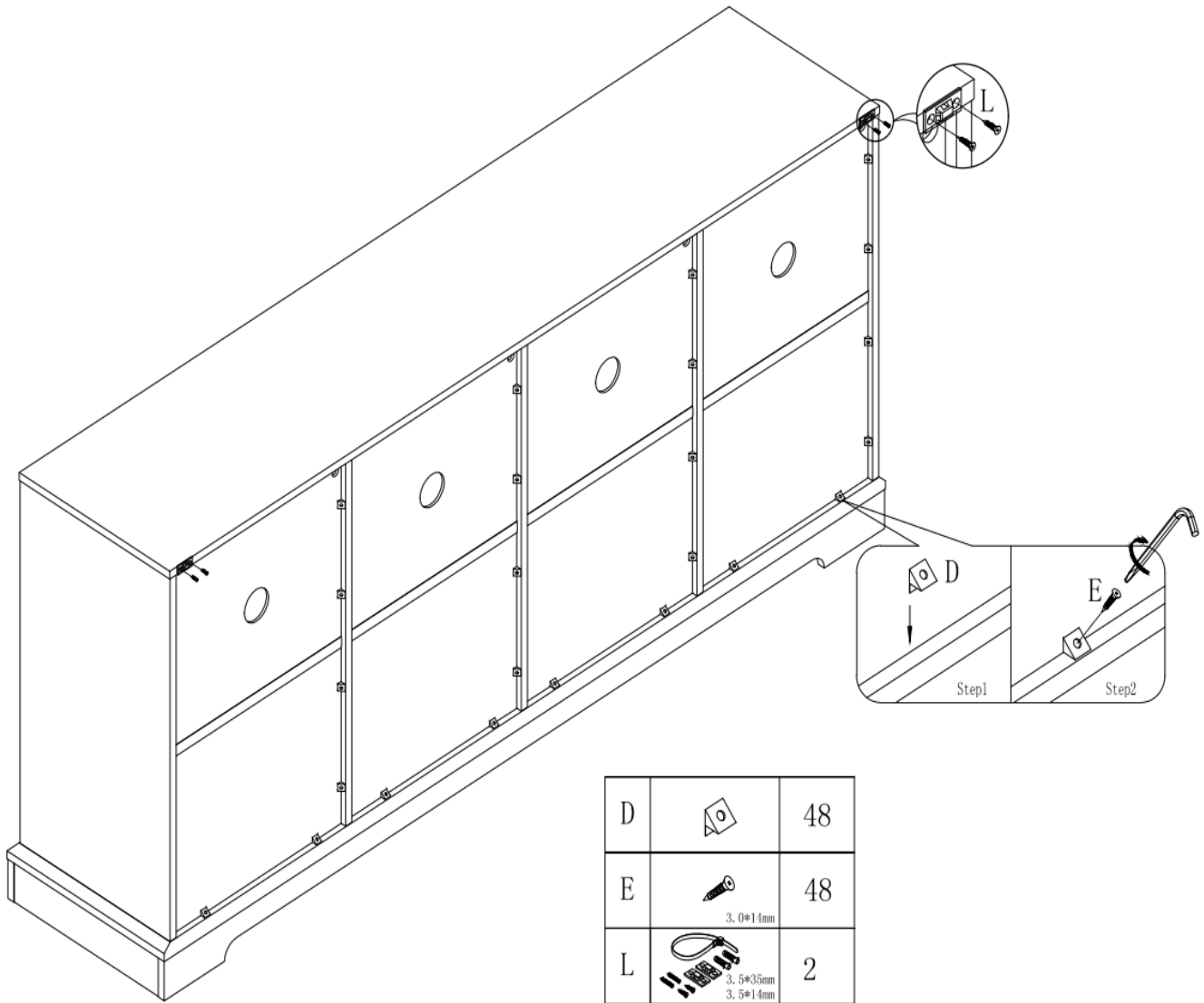

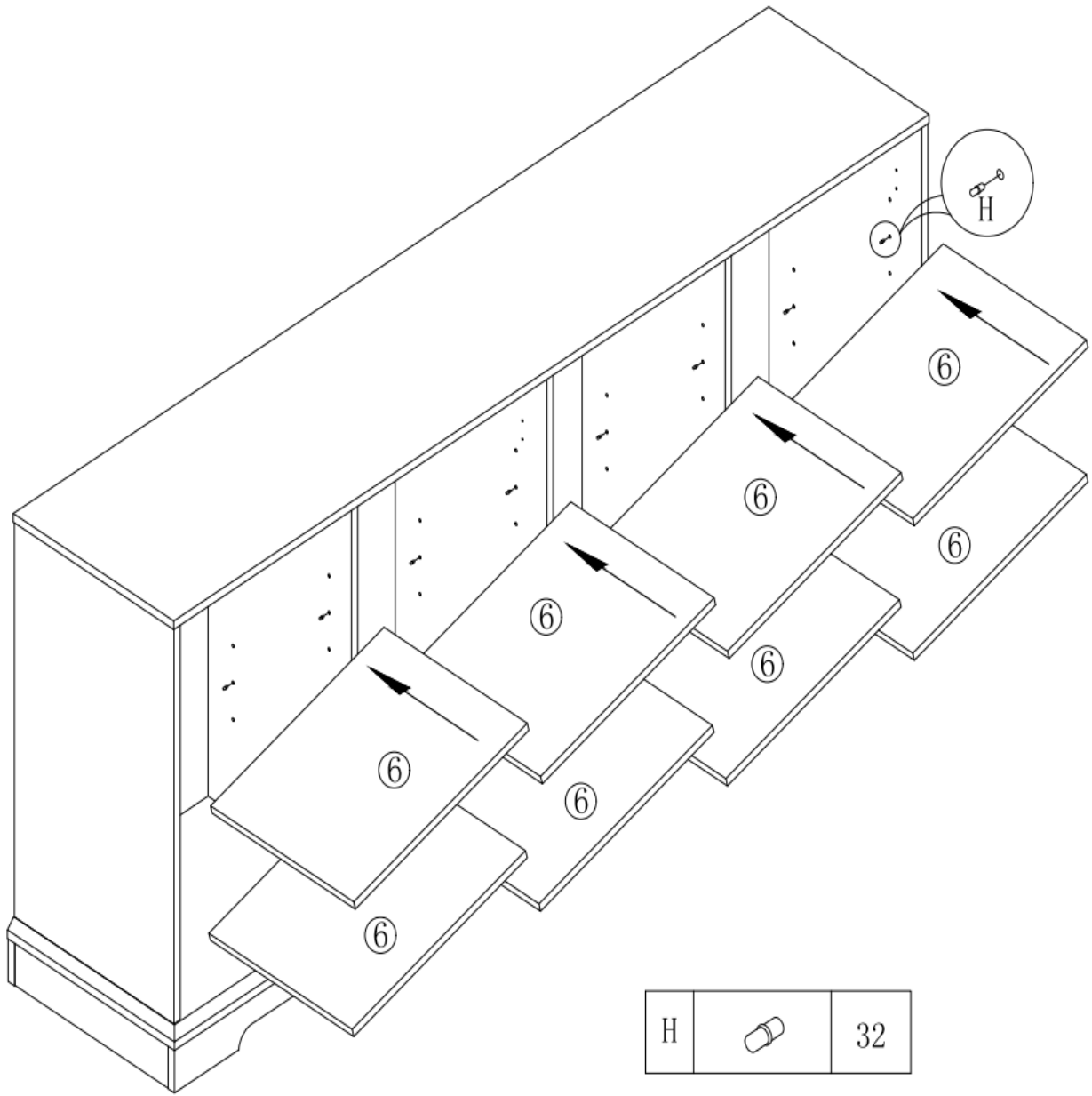

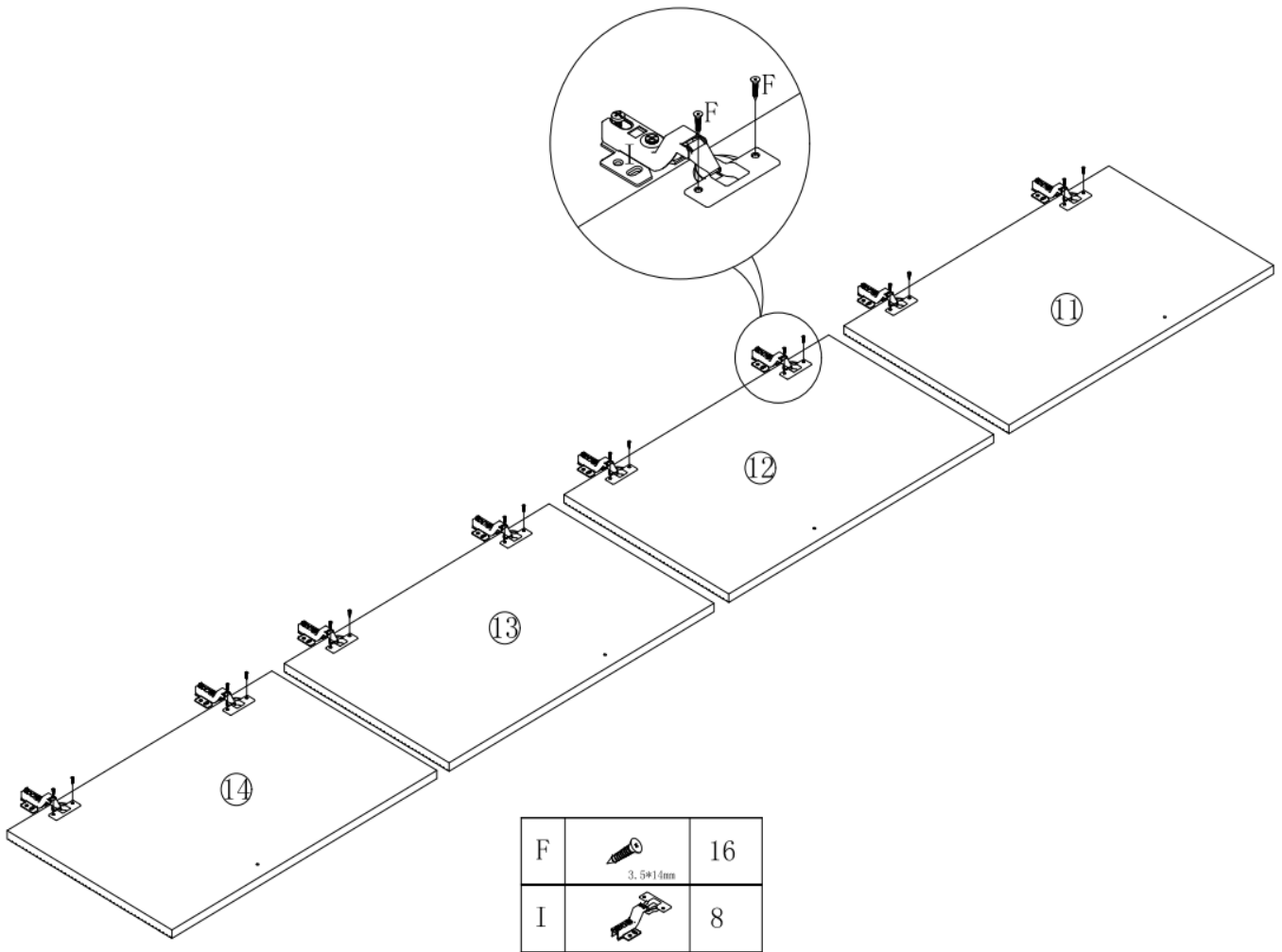

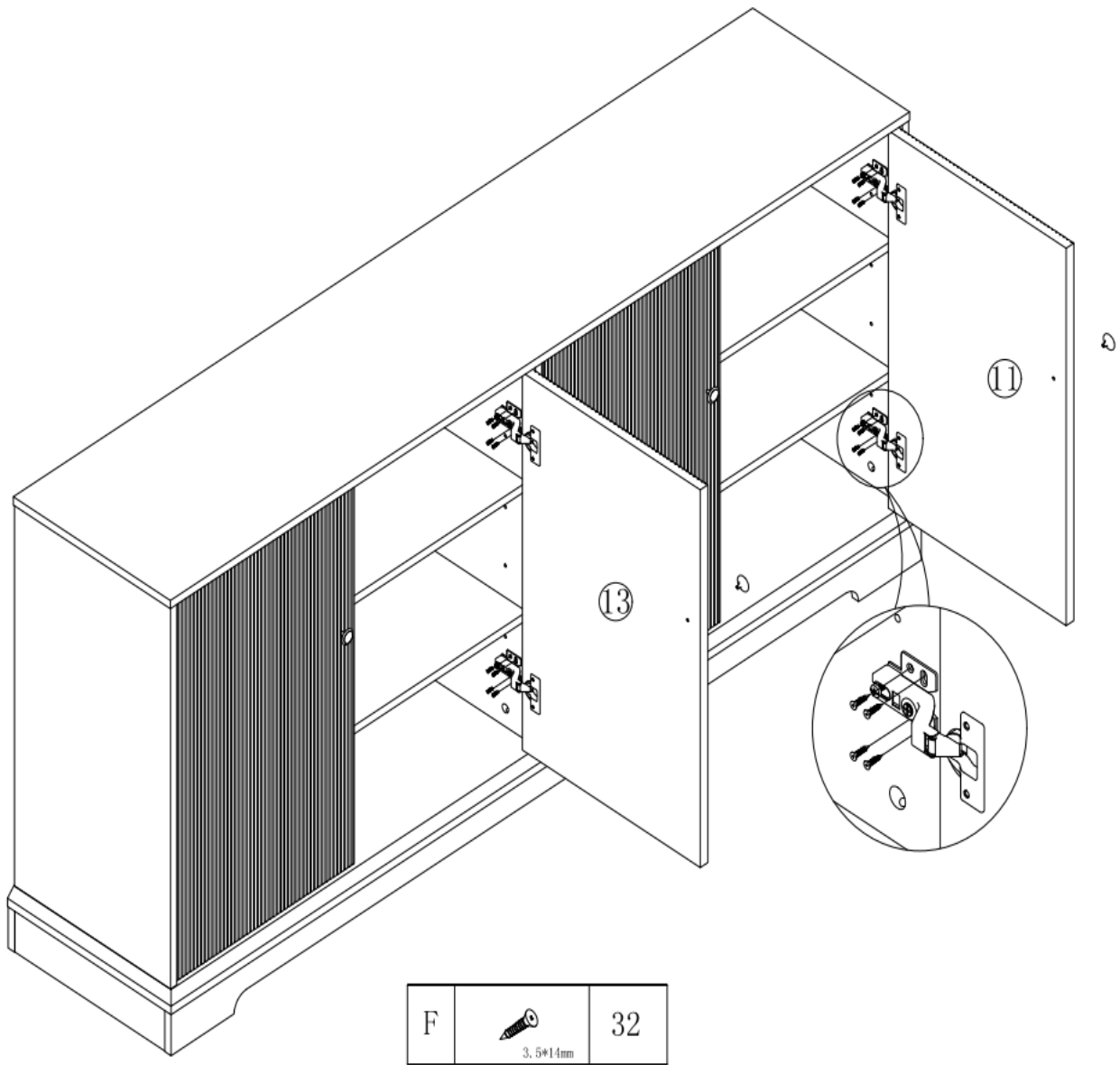

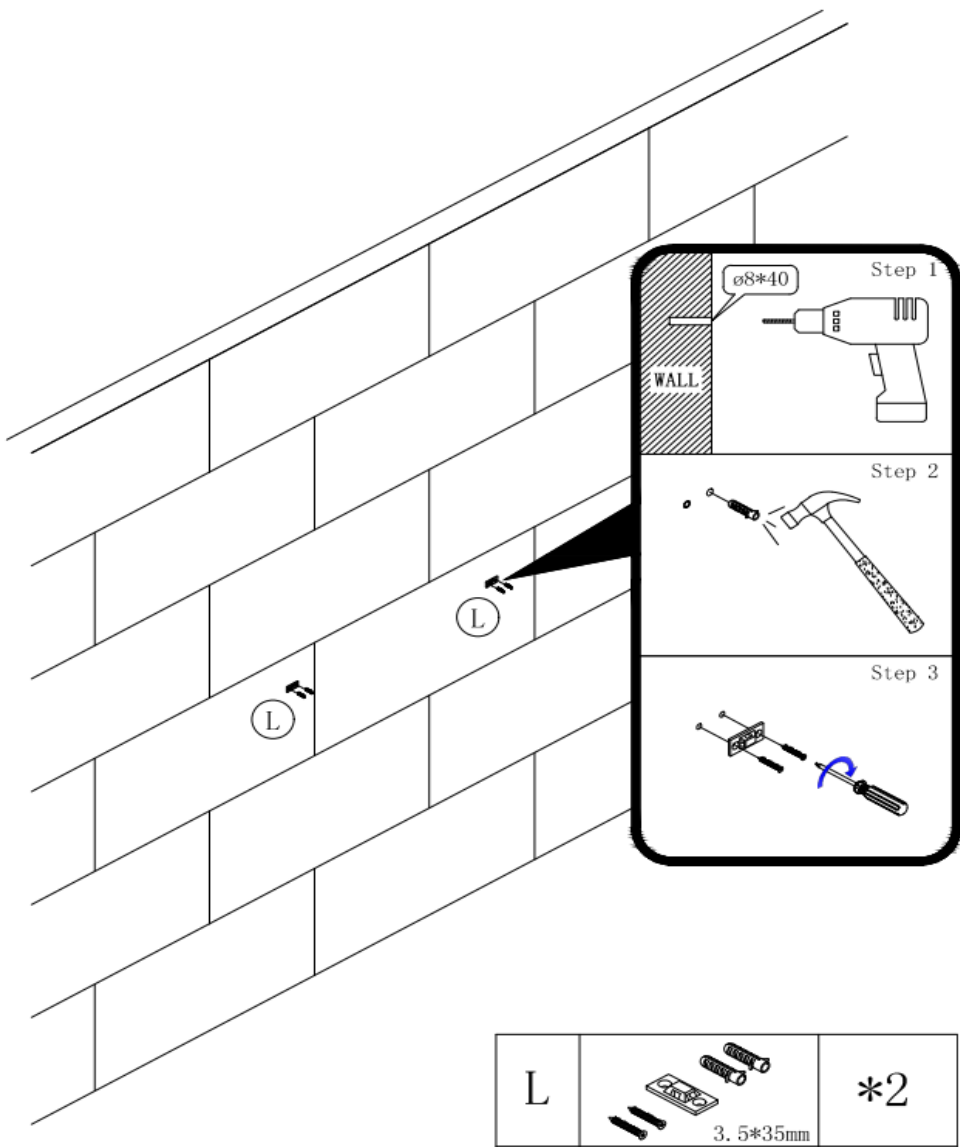

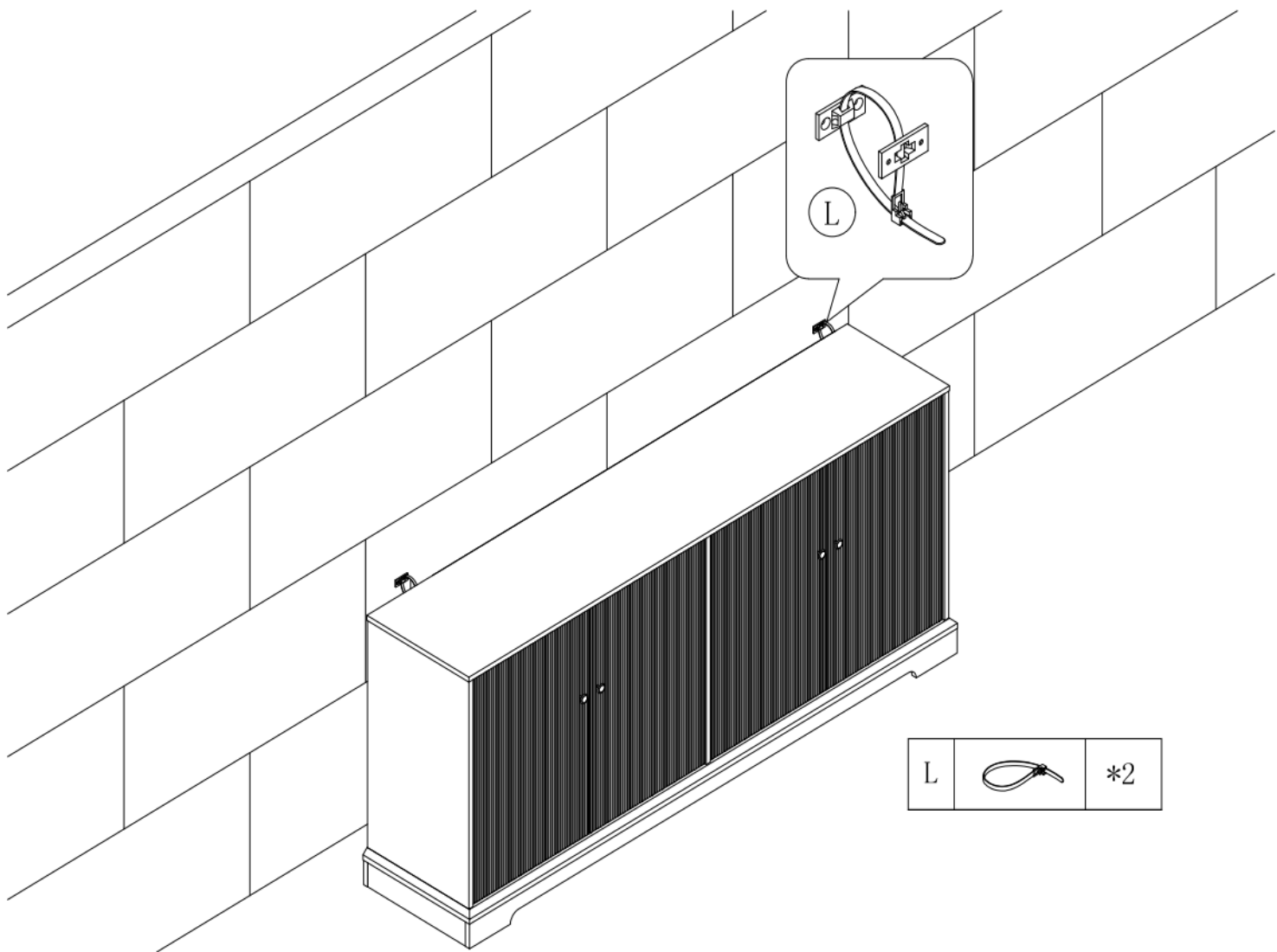



L		*2
---	---------------------------------------------------------------------------------------	----

PLEASE DO NOT RETURN TO STORE



Please do not return this product to the retailer!
We are able to assist you in ANY way!

If you find that you have any trouble with assembly or missing or damaged parts please contact the seller.