



ACHTUNG! CAUTION! ATTENTION! ATTENCION!

Beim Aufbau dieses Möbelstücks liegt die alleinige Verantwortung bei der Person, die diesen Aufbau durchführt. Alle Bauteile samt Zubehör müssen bitte genauestens nach Montageanleitung zusammengeführt werden.

It is the responsibility of the persons assembling the furniture to properly install all components and hardware as specified in these instructions. Please follow strictly the order of assembly shown in these instructions!

Il est de la responsabilité des personnes qui montent le meuble d'installer correctement tous les composants et la quincaillerie, comme mentionné dans les instructions de montage. Veuillez suivre strictement l'ordre d'assemblage des instructions de montage!

Son responsables las personas que montan el mueble de instalar correctamente todos los componentes y la quincaillería tal como se menciona en las instrucciones de montaje. Rogamos sigan estrictamente el orden de ensambladura de las instrucciones de montaje!

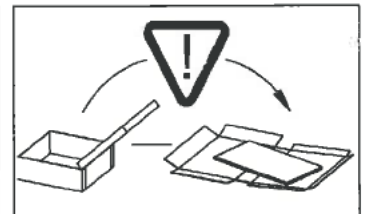
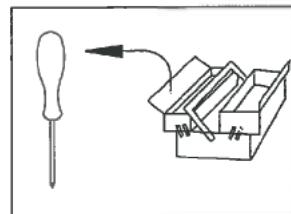
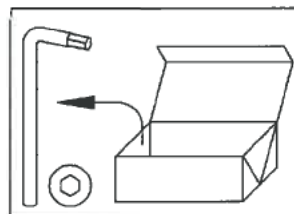
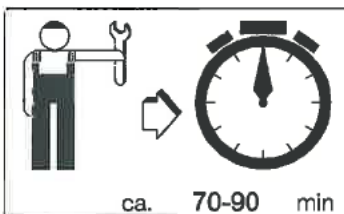
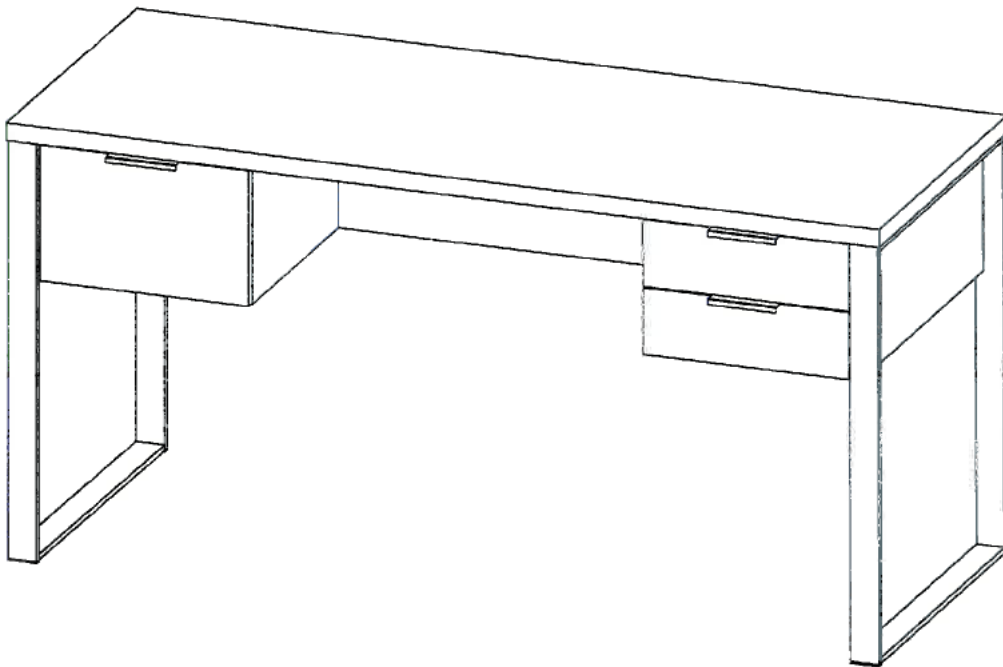

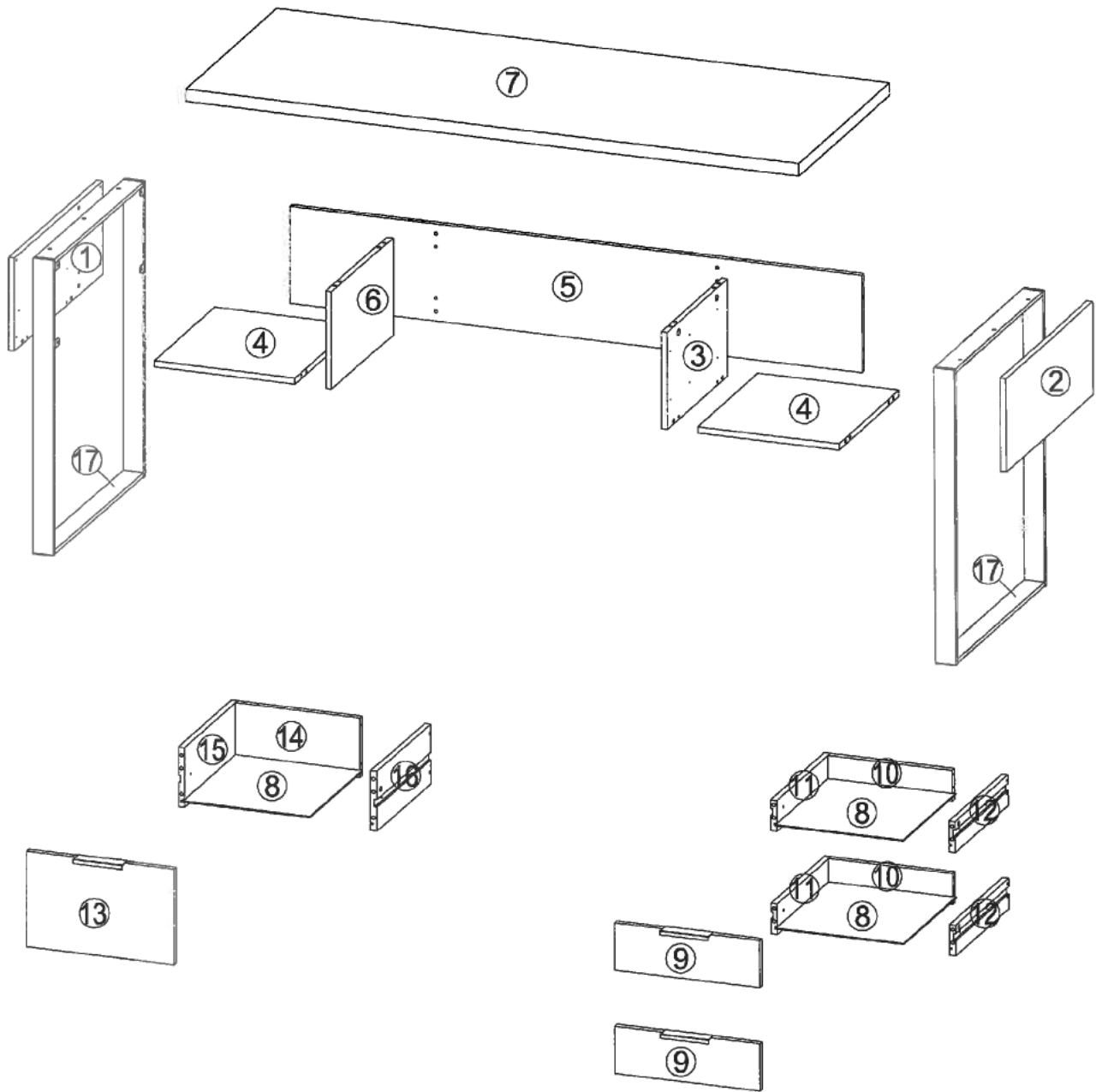

BOX 1

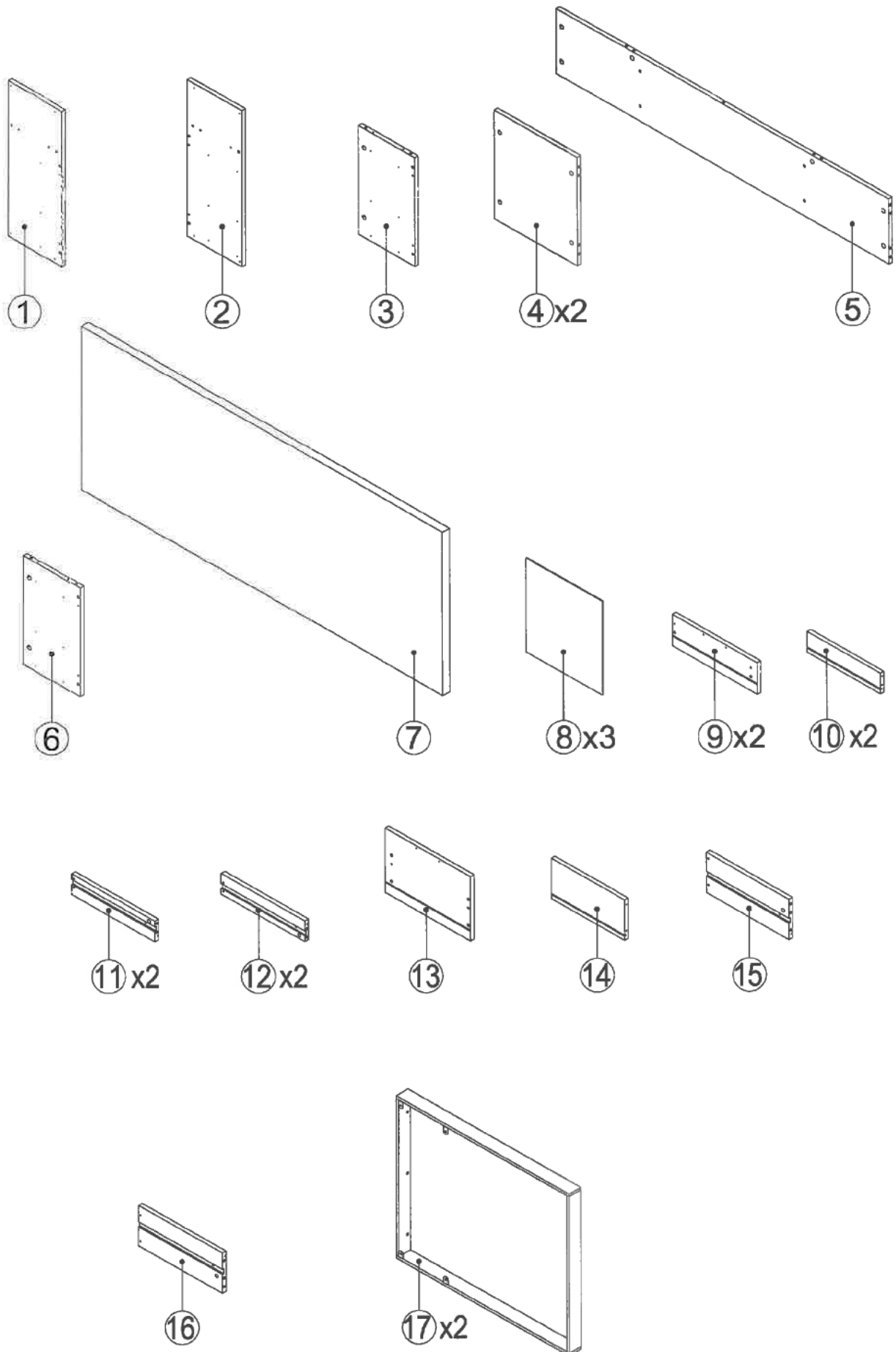









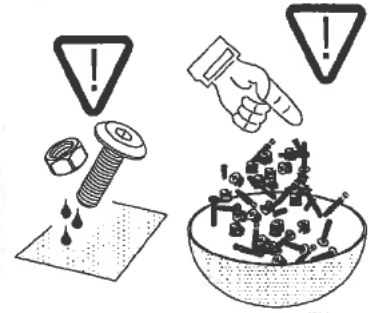



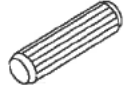



An den Beschlägen kann Fett und Schmutz haften ! Vor der Montage für eine schmutzunempfindliche Unterlage sorgen !

Some metal fittings might be coated with a slight film of grease and dirt, therefore please use dirt resistant material on the floor prior installation.

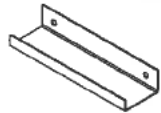

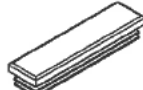

Certains pièces de quincaillerie peuvent comporter un léger film salissant. Merci d'en tenir compte lors du montage en protégeant préalablement votre sol !

Una parte de la tornillería puede tener una capa de grasa. Le rogamos ponga atención a posibles manchas sobre el suelo en el momento del montaje





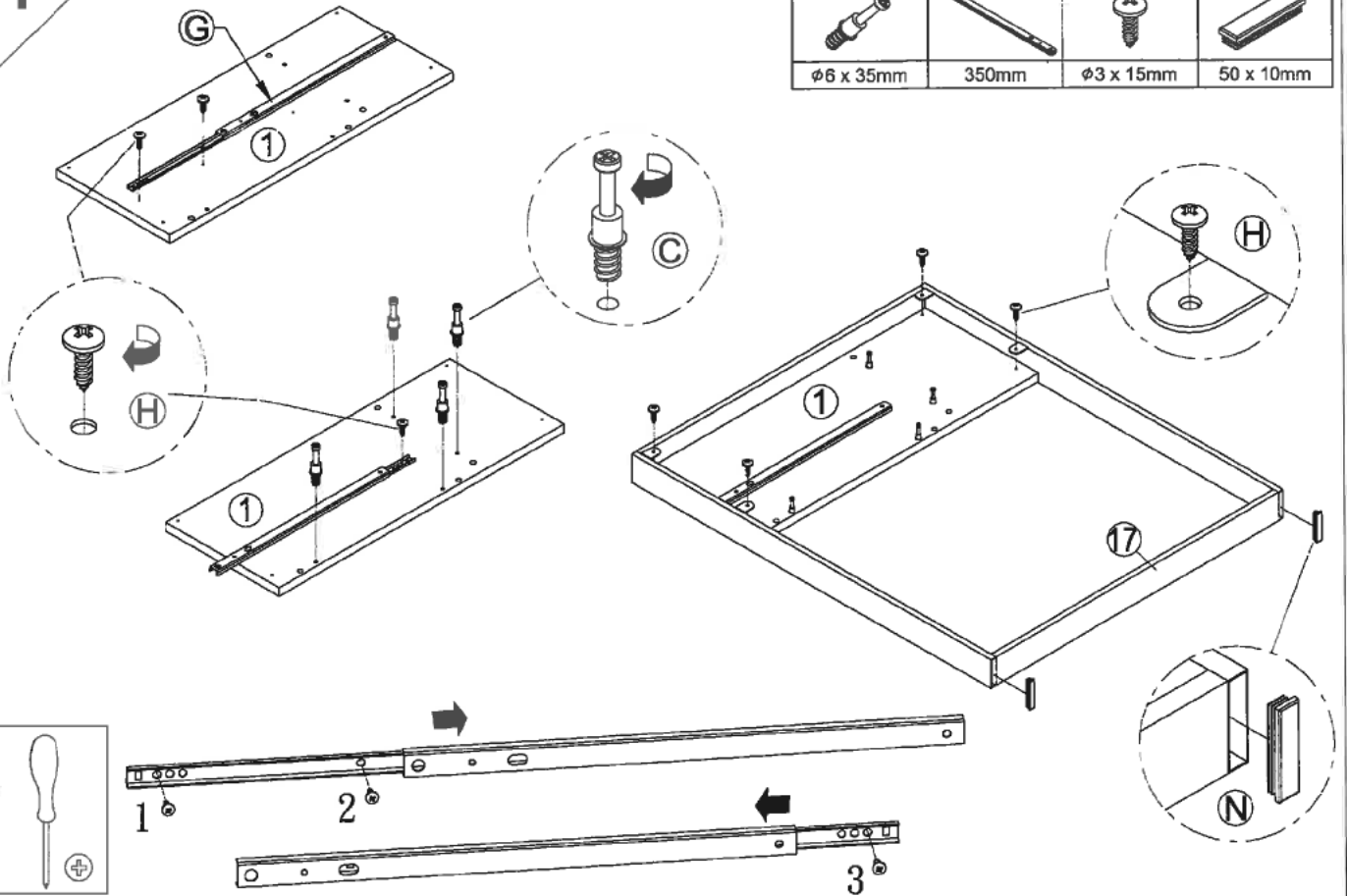

A x 1	B x 31	C x 24	D x 18	E x 4	F x 12
					
LEIM / GLUE	∅8 x 30mm	∅6 x 35mm	∅15mm	42mm	∅4.2 x 35mm
G x 6	H x 32	I x 6	J x 3	K x 6	L x 6
					
350mm	∅3 x 15mm	M4 x 15mm	120mm	∅12mm	M6 x 28mm
M x 1	N x 4	O			
					
M4	50 x 10mm	∅20mm			

1

C x 4	G x 1	H x 7	N x 2
			
∅6 x 35mm	350mm	∅3 x 15mm	50 x 10mm





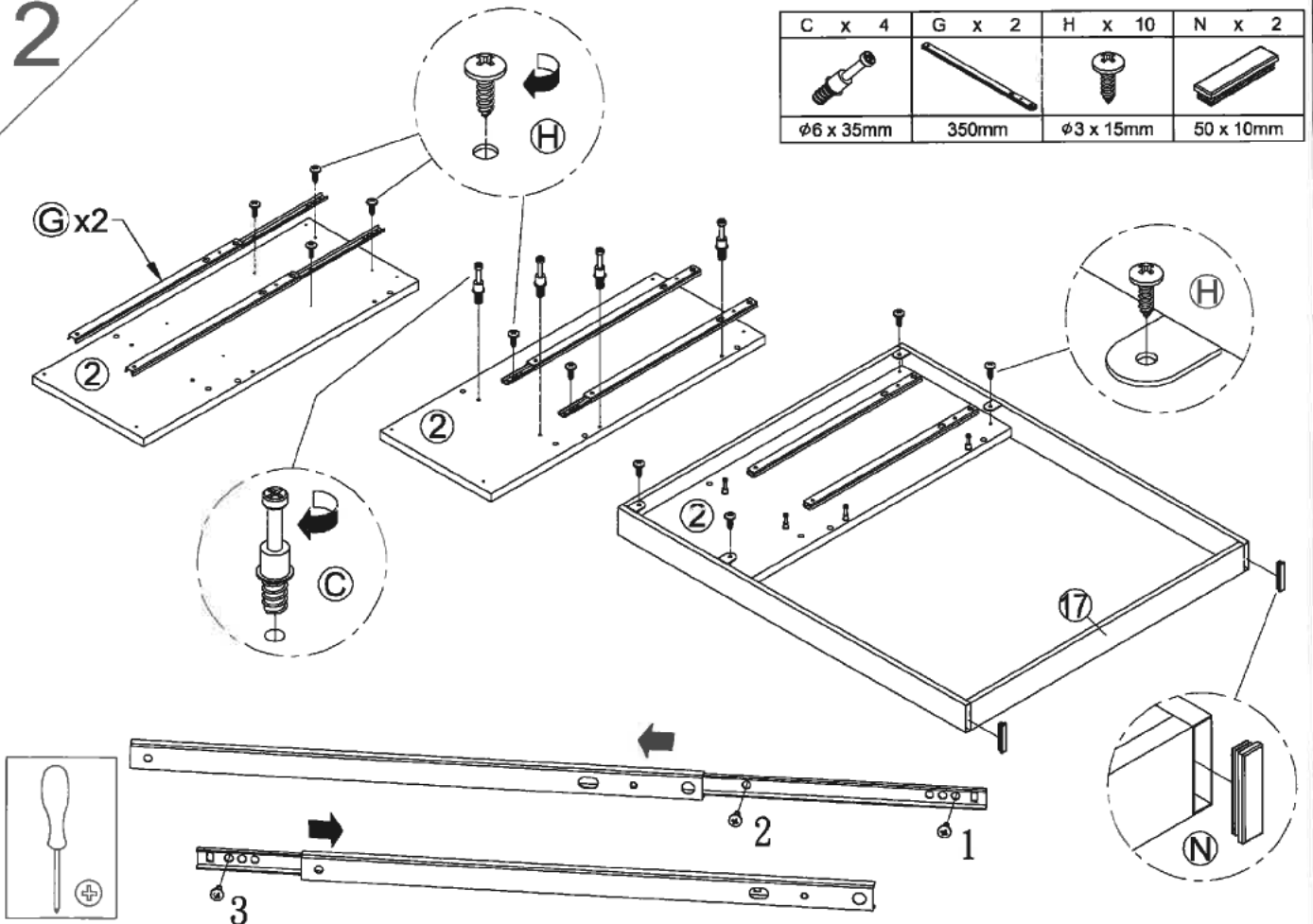

2

C x 4	G x 2	H x 10	N x 2
			
∅6 x 35mm	350mm	∅3 x 15mm	50 x 10mm



3



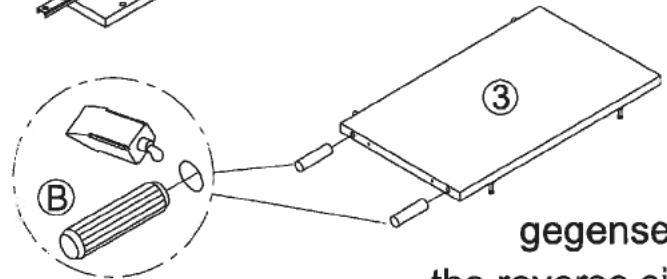
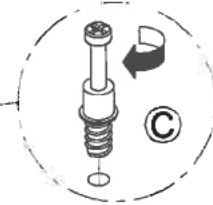
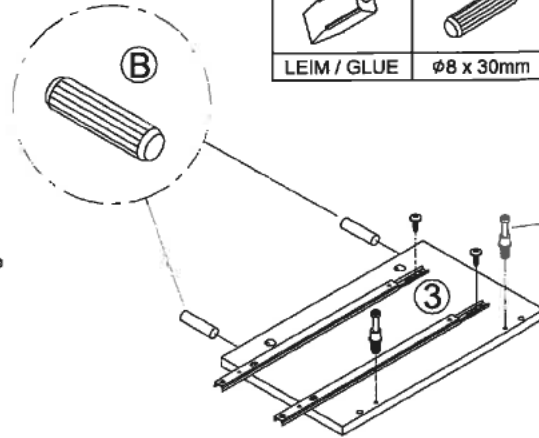
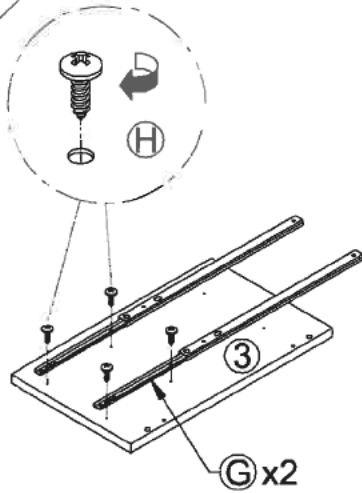

A	B x 4	C x 2	G x 2	H x 6
				
LEIM / GLUE	∅8 x 30mm	∅6 x 35mm	350mm	∅3 x 15mm

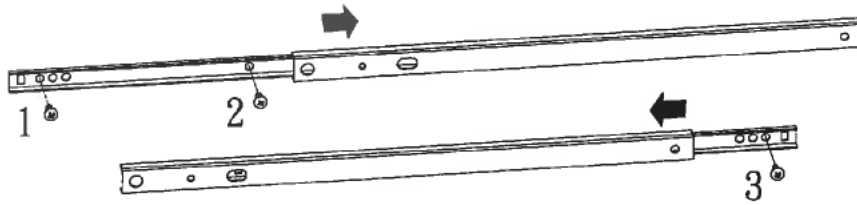
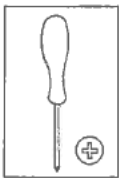

gegenseite
the reverse side



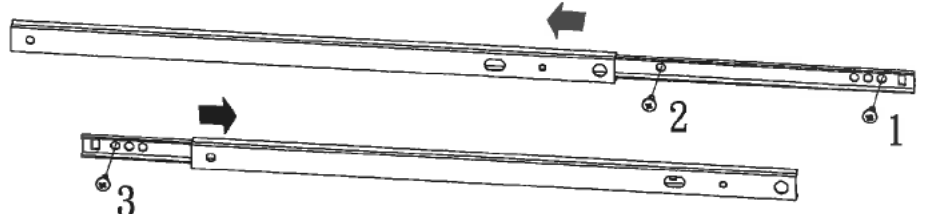
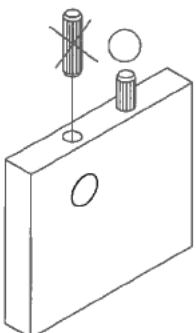
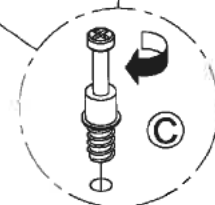
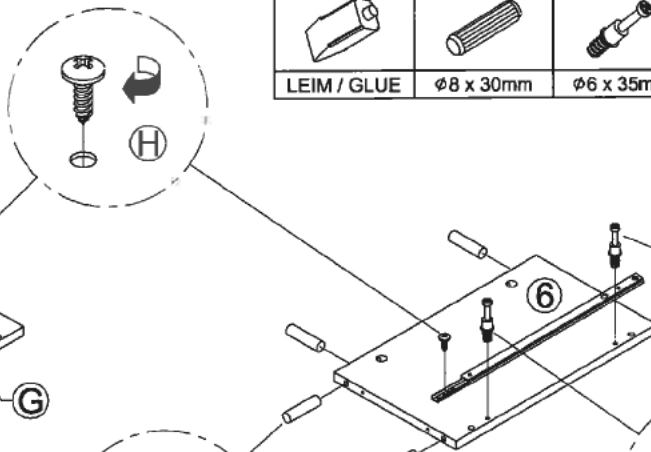
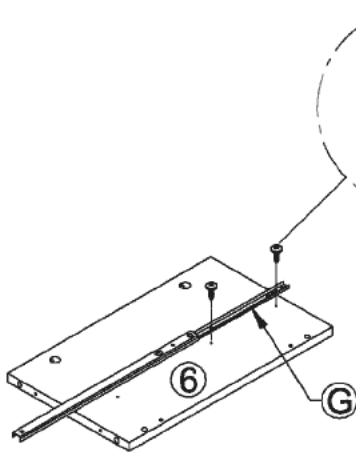

4

A	B x 4	C x 2	G x 1	H x 3
				
LEIM / GLUE	∅8 x 30mm	∅6 x 35mm	350mm	∅3 x 15mm





5

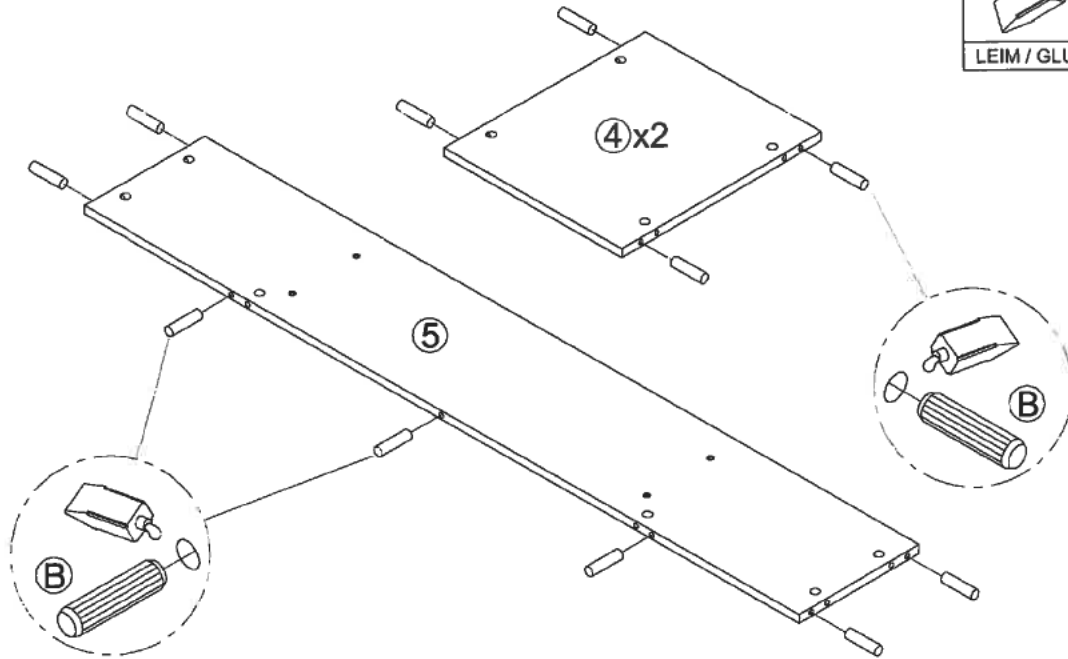

A	B x 15
	
LEIM / GLUE	∅8 x 30mm

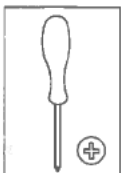
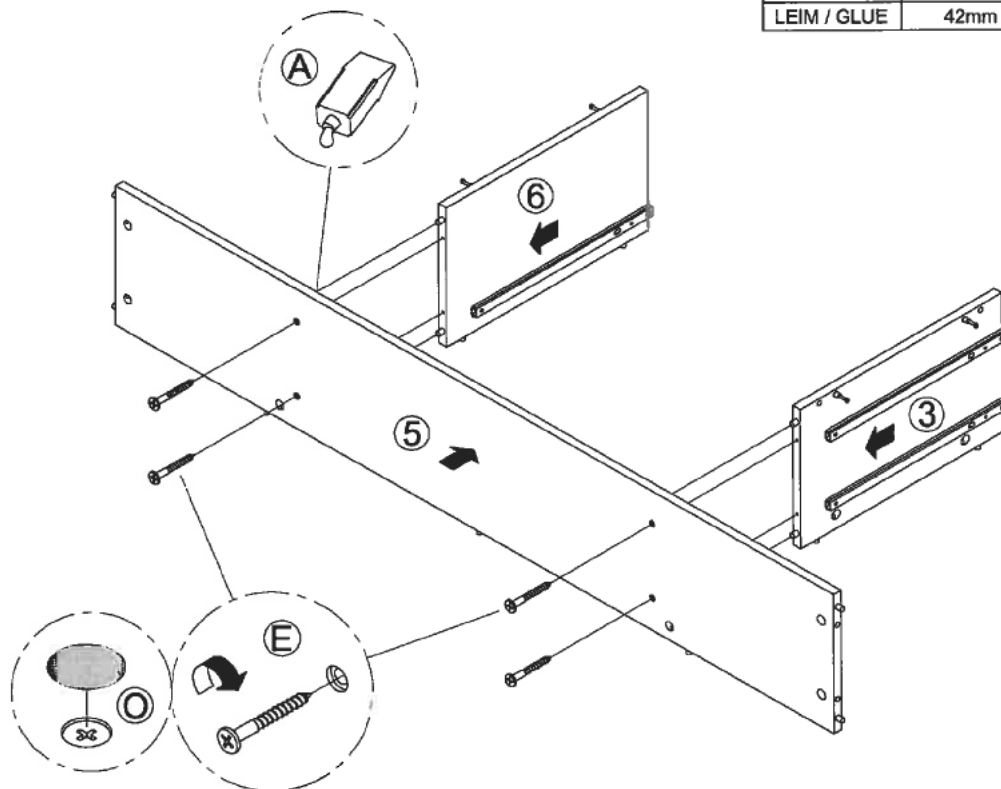

6

A	E x 4	O x 4
		
LEIM / GLUE	42mm	∅20mm



A	D x 12	O x 12
		
LEIM / GLUE	Ø15mm	Ø20mm

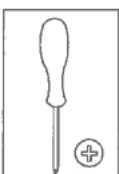
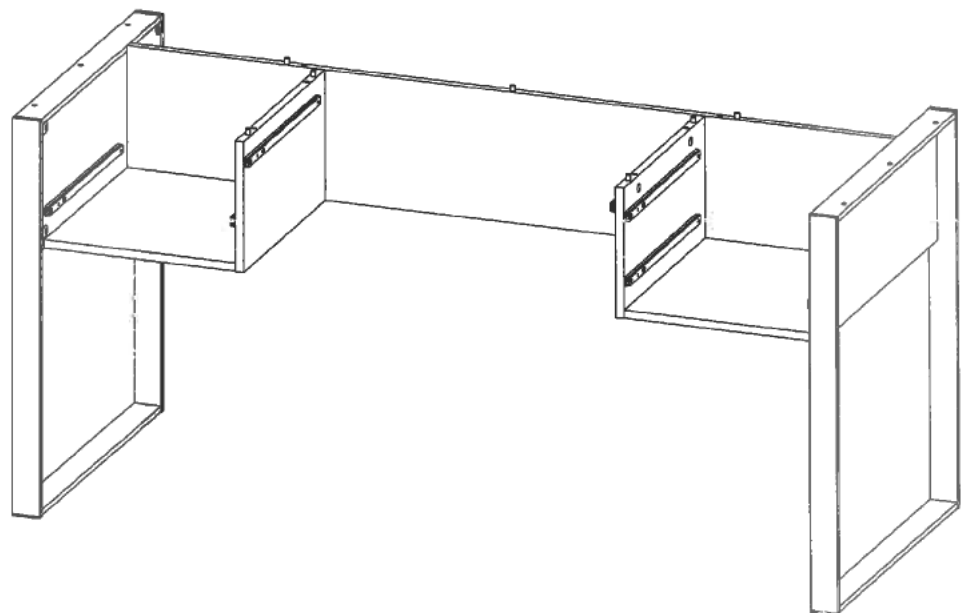
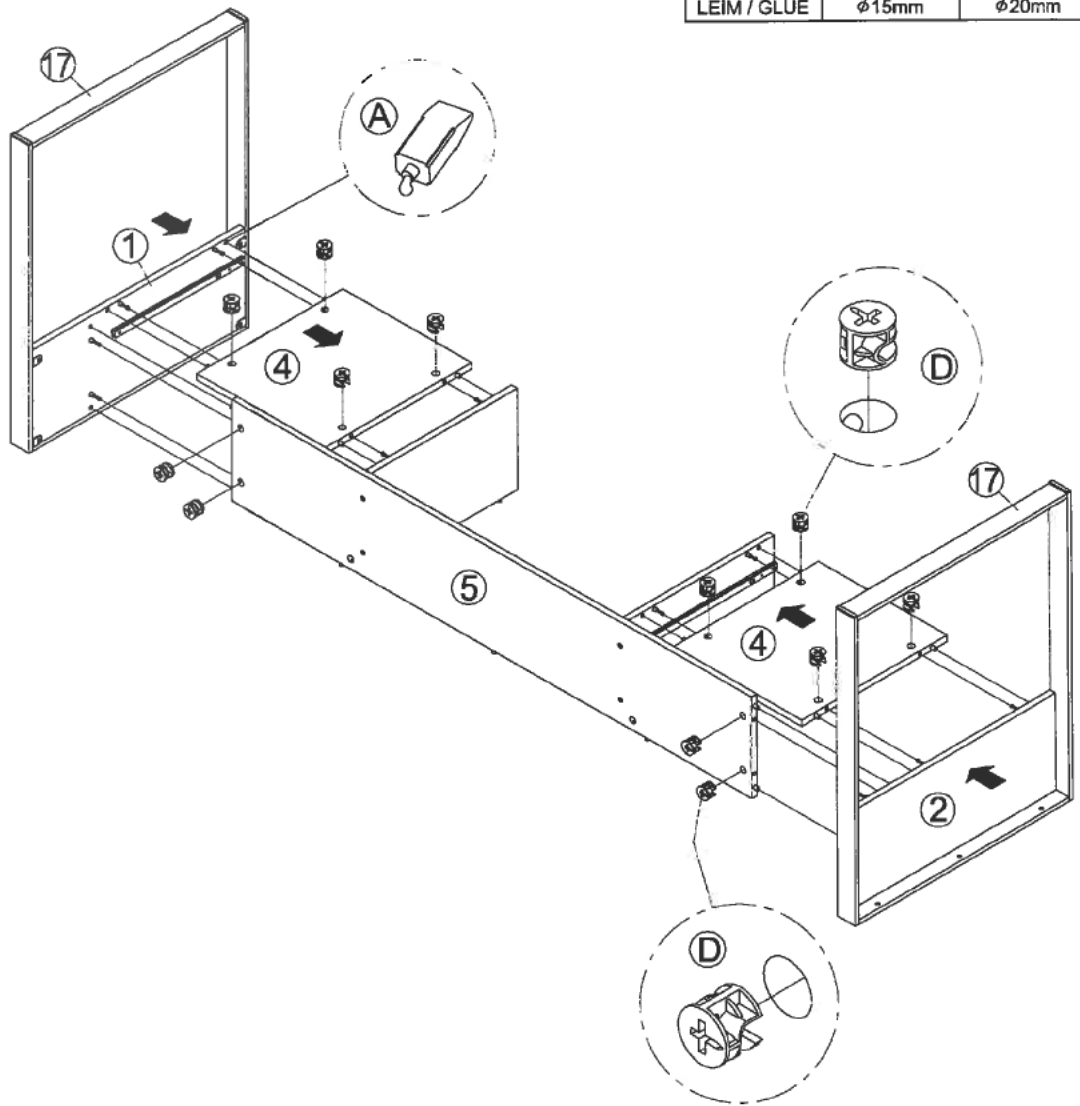
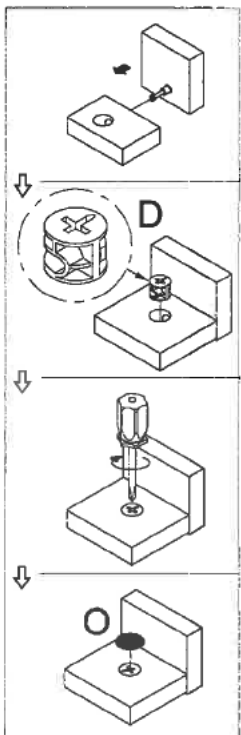



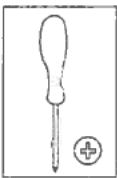
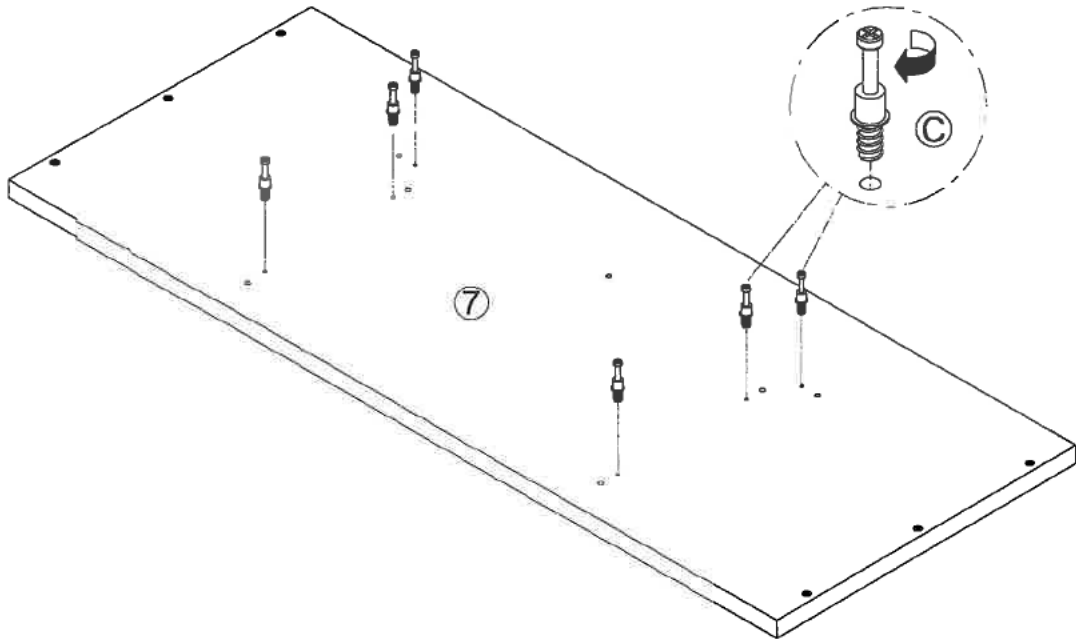

8

9 / 13

C	x	6
		
Ø6 x 35mm		







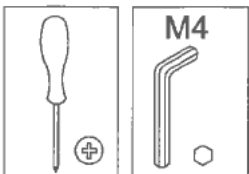
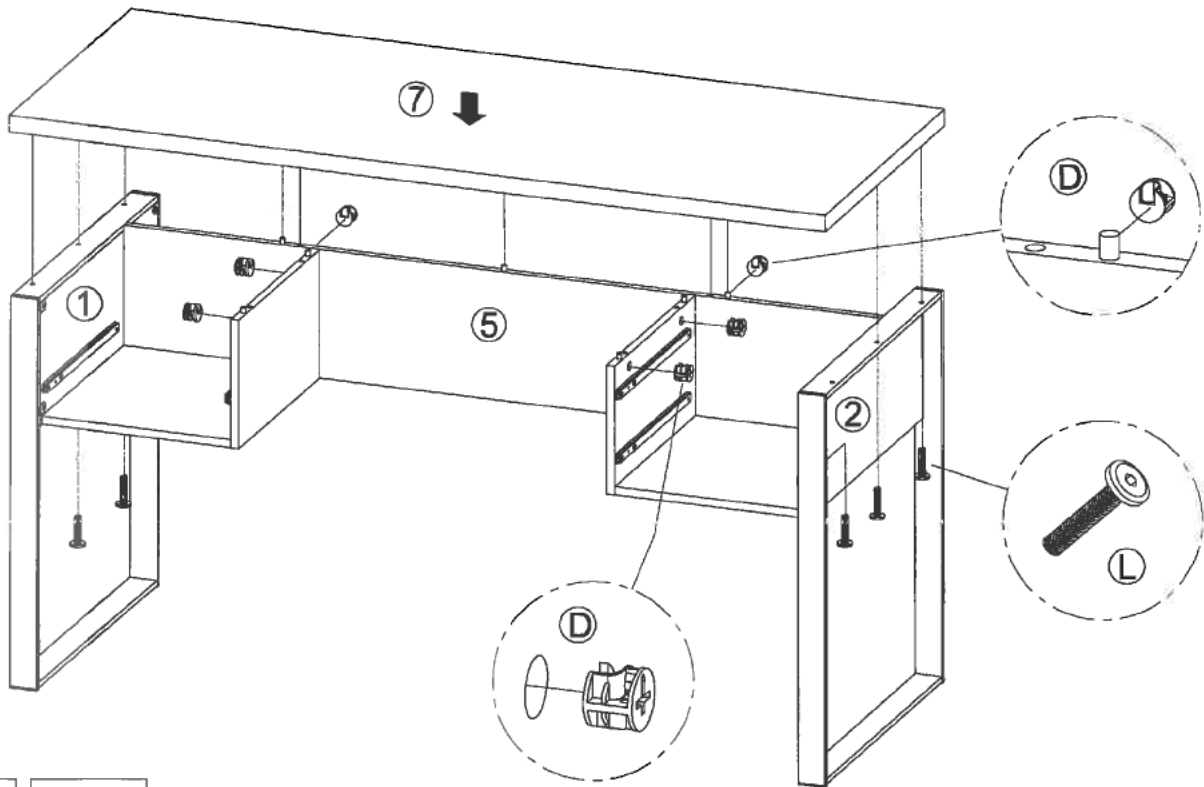

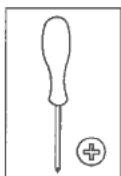
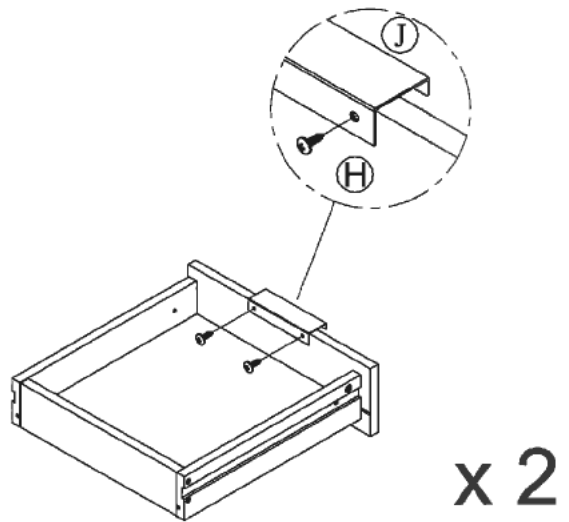
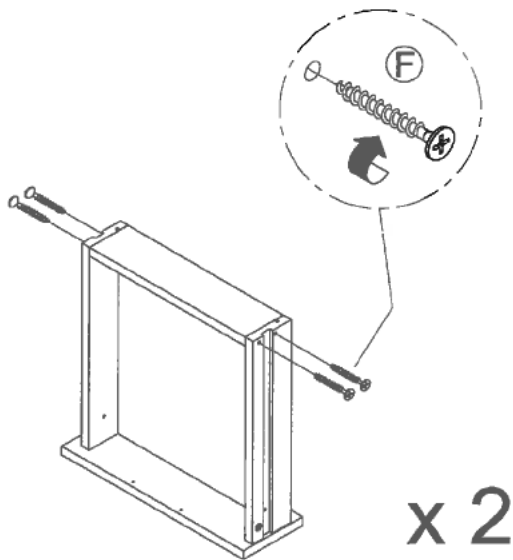
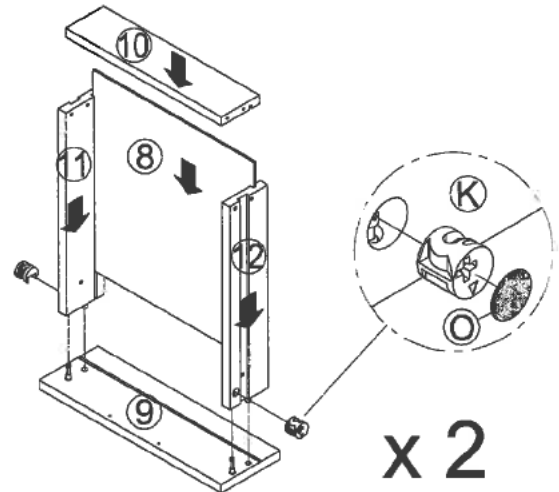
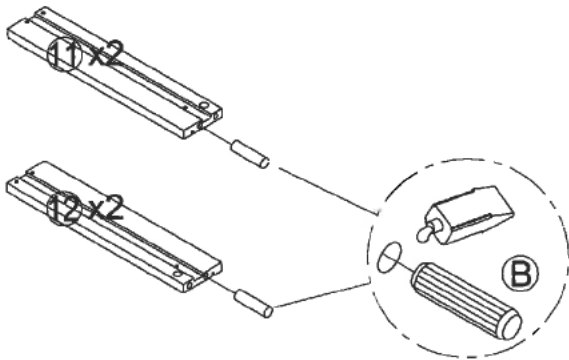
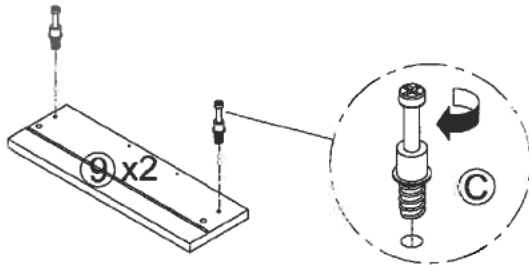

9

A	D x 6	L x 6	M x 1	O x 6
				
LEIM / GLUE	Ø15mm	M6 x 28mm	M4	Ø20mm



A	B x 4	C x 4	F x 8	H x 4	J x 2	K x 4	O x 4
LEIM / GLUE	∅8 x 30mm	∅6 x 35mm	∅4.2 x 35mm	∅3 x 15mm	120mm	∅12mm	∅20mm



A	B x 4	C x 2	F x 4	H x 2	J x 1	K x 2	O x 2
							
LEIM / GLUE	ø8 x 30mm	ø6 x 35mm	ø4.2 x 35mm	ø3 x 15mm	120mm	ø12mm	ø20mm

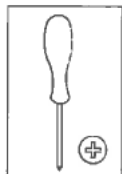
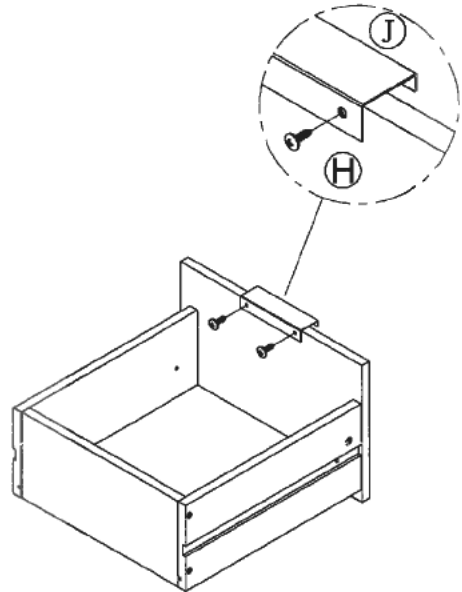
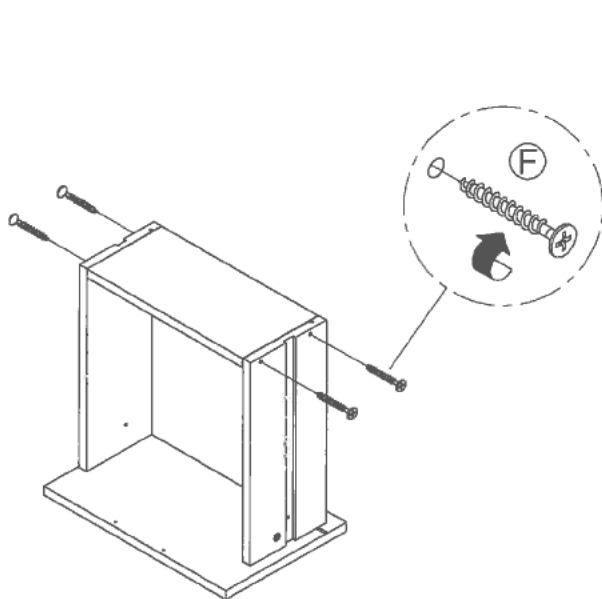
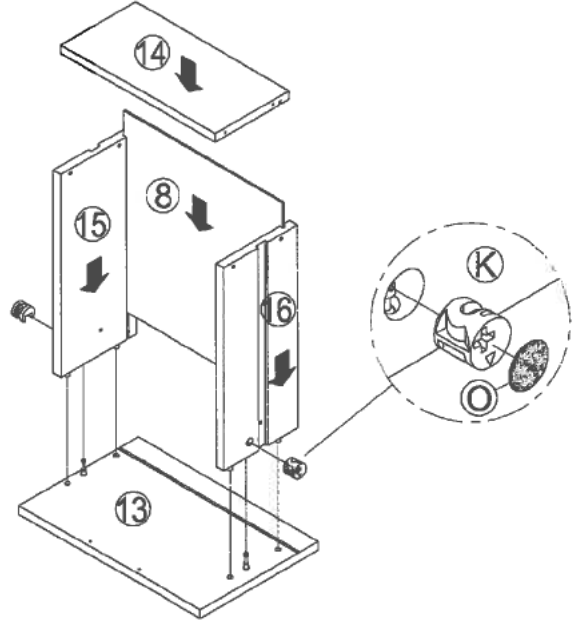
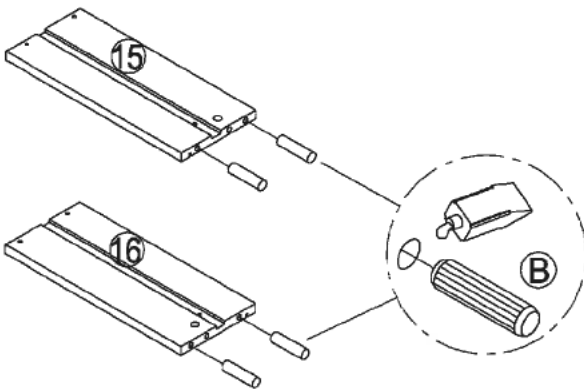
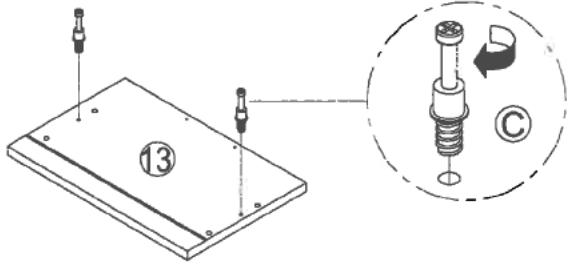

12

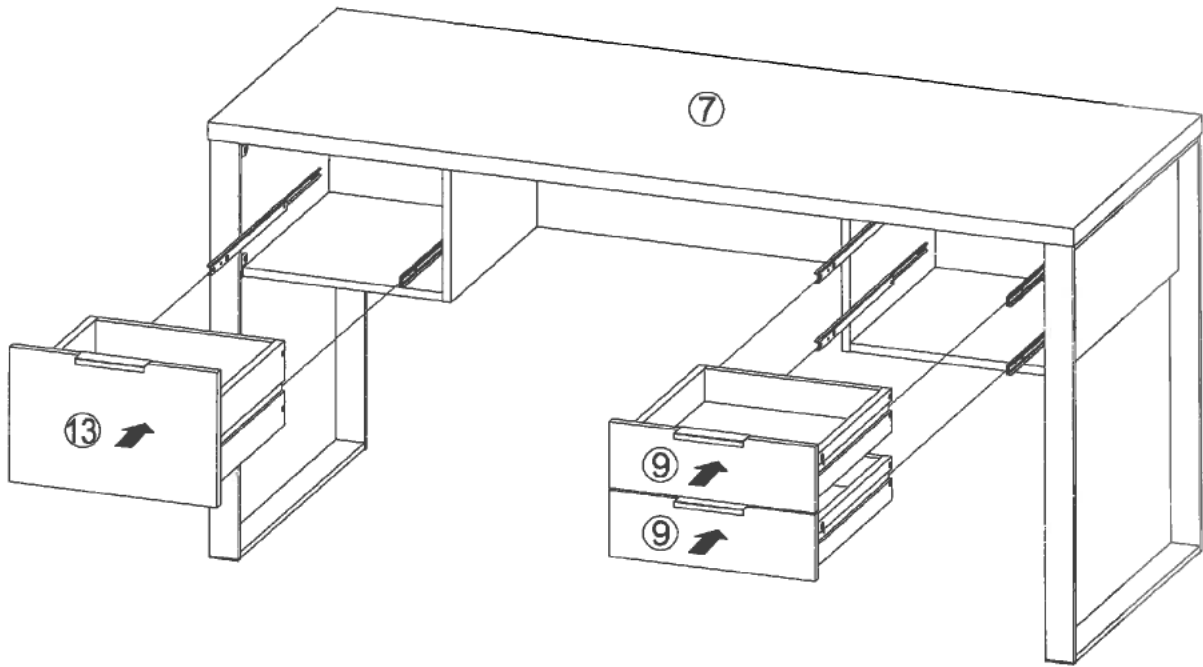

13

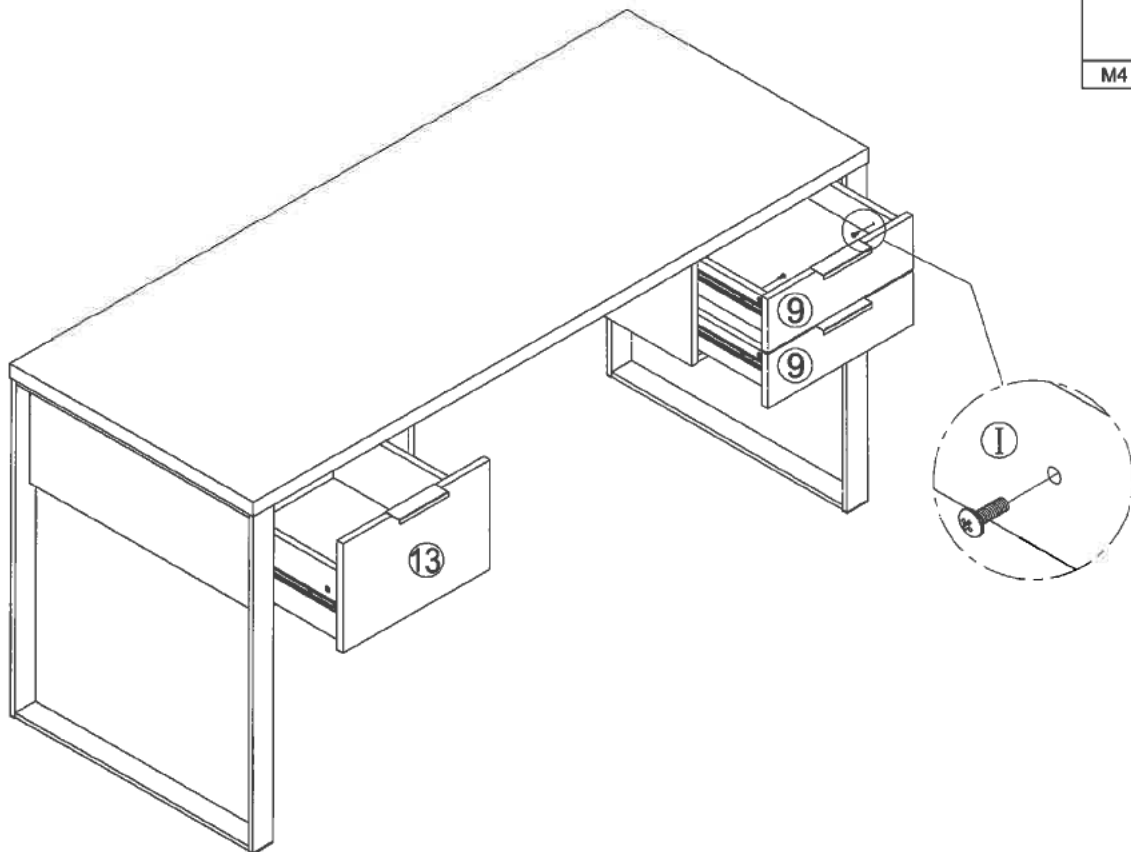

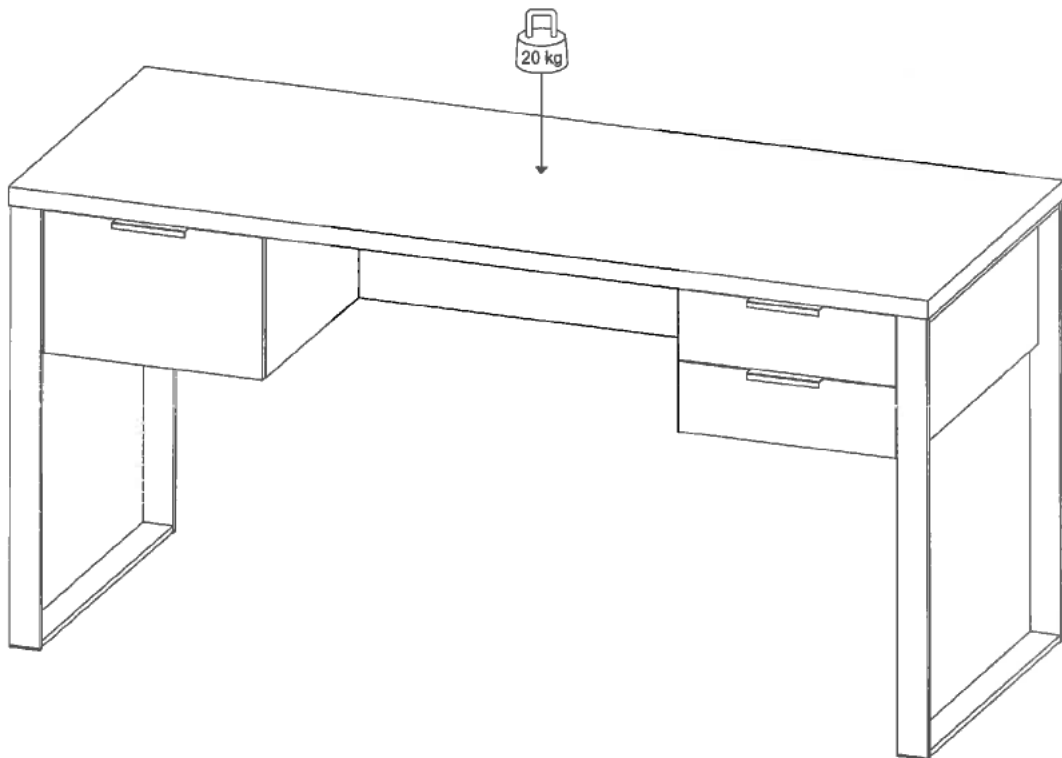
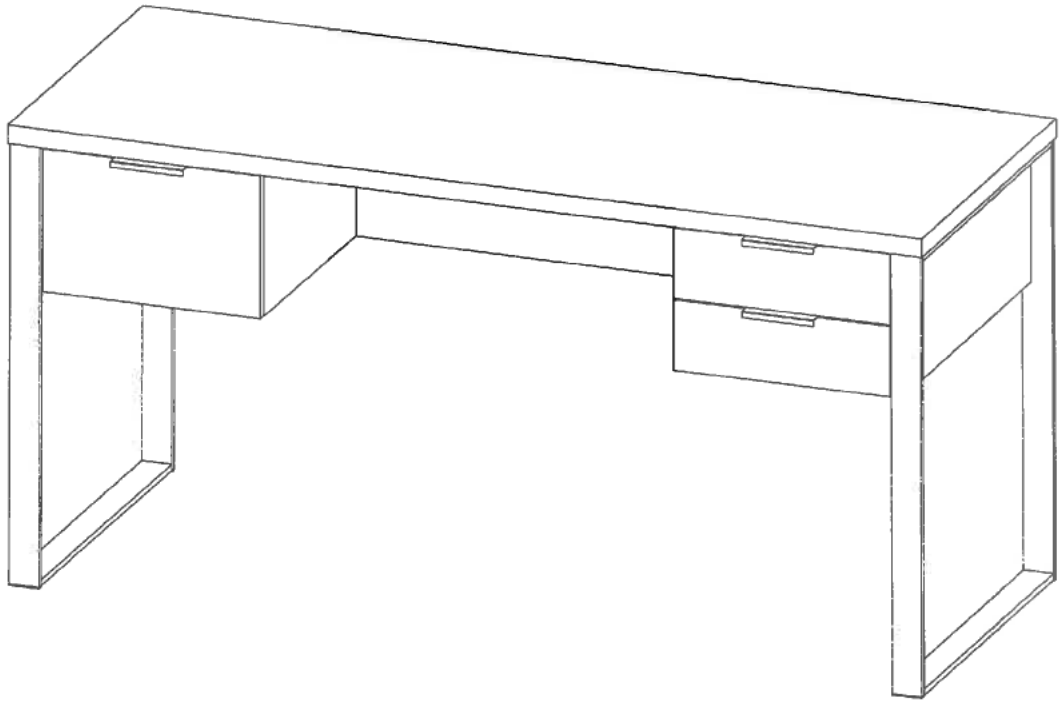



Karton
Box
Carton
Cartón









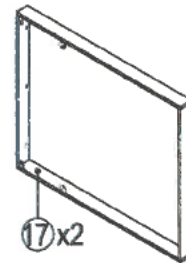
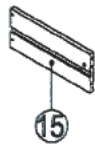
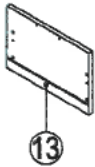
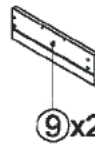
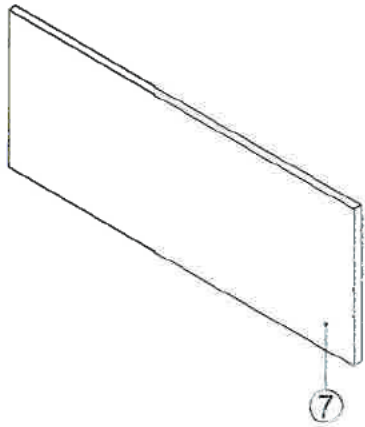
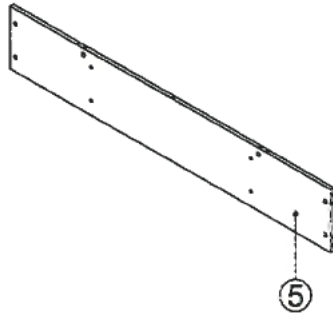
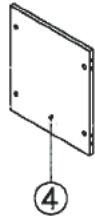





EL SERVICIO CARTA

SERVICE CARD

LE SERVICE CARTE

SERVICEKARTE

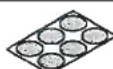

A  LEIM / GLUE	B  ø8 x 30mm	C  ø6 x 35mm	D  ø15mm	E  42mm	F  ø4.2 x 35mm	G  350mm	H  ø3 x 15mm
I  M4 x 15mm	J  120mm	K  ø12mm	L  M6 x 28mm	M  M4	N  50 x 10mm	O  ø20mm	

Firma/Company/Société/Sociedad/
Herr,Frau/Mr,Mrs/M,Sr/Mme,Sra:

Z. Hd. von/Att. to/
A l'attention de/A la atención de:

Tel.-Nr./Phone/
Tel.Nº/Tel.Nº:

Fax:

Modell/Model/
Modèle/Modelo:

gemaakt bei/bought at/
acheté chez/comprado en:

Beanstandung/Reason of recl./Réclamation/Reclamación:
(Bemerkungen/Notice/Remarques/Propuesta de mejora)

Straße/Street/
Rue/Calle:

PLZ,Ort/Code, City/Code postal,
Ville/Código postal, ciudad:

Datum/Date/
Date/Fecha:

Unterschrift/Signature/
Signature/Firma:

Farbe/Colour/Coloris/Color:
(unbedingt angeben/very important/
obligatoire/obligatorio)

Serial-Nr. / Serial no. / Référence / N° de serie:

DEUTSCH

D

Sehr geehrter Kunde,
es freut uns, dass Sie sich für eines unserer Qualitätsprodukte entschieden haben. Sollten Sie trotz eingehender Kontrollen Beanstandungen haben, bitten wir Sie, die Servicekarte auszufüllen. Kennzeichnen Sie nicht vorhandene oder defekte Teile auf der Servicekarte durch Ankreuzen. Bitte senden oder faxen Sie uns die Servicekarte zurück, damit wir Ihre Beanstandungen überprüfen und bearbeiten können. Selbstverständlich können Sie uns auch per Telefon oder per E-Mail erreichen. Bitte teilen Sie uns ebenfalls die Seriennummer von diesem Schreiben mit. Sollten Sie sonstige Hinweise oder Verbesserungsvorschläge haben, wären wir für Ihren Kommentar dankbar. Wir hoffen, dass Sie bei Zufriedenheit unsere Produkte weiterempfehlen werden. Vielen Dank,

ENGLISH

GB

Dear Customer,
Thank you for choosing one of our quality products. All our products are subject to strict quality controls. If you have a complaint despite thorough checks, we ask you to fill in this service card. Mark missing or defective parts with a cross. Please send or fax this service card to us so that we can check and deal with your complaint as soon as possible. You are welcome to send your comments and suggestions. Please feel free to recommend our products to other persons. Thank you for your cooperation,

FRANCAIS

F

Cher Client,
Nous nous réjouissons de votre décision de choisir notre produit. Si vous devez nous adresser une réclamation en dépit de nos contrôles approfondis, nous vous demandons de bien vouloir remplir la carte de service. Indiquez les pièces manquantes ou défectueuses en mettant une croix. Nous vous prions de nous renvoyer la carte de service par la poste ou par fax afin que nous puissions vérifier vos réclamations et y donner suite. Vous pouvez bien sûr nous joindre par téléphone ou par e-mail. Veuillez nous communiquer aussi le numéro de série de cette lettre. Si vous aviez d'autres remarques ou propositions d'amélioration, nous vous serions reconnaissants de vos commentaires. Nous espérons en cas de satisfaction que vous recommanderez notre produit. Merci beaucoup, la

ESPAÑOL

E

Estimado Cliente,
Nos complace que usted haya optado por nuestro producto. Si a pesar de los constantes controles tuviera reclamaciones, le rogamos rellenar esta tarjeta de servicio. No marque con cruces las piezas que falten o defectuosas. Envíenos por correo o por fax la tarjeta de servicio para controlar sus reclamaciones y poder tramitarlas. También puede usted tomar contacto con nosotros por teléfono o por mail. Sírvase comunicarnos también el número de serie de esta carta. Si tuviera más advertencias o propuestas de mejora, les agradeceríamos nos mandara sus comentarios eventuales. Esperamos en caso de satisfacción que recomendara nuestro producto. Muchas gracias, la Sociedad