

INSTALLATION MANUAL



Scan for
Installation video

Model : FCD0070_00
Support:ServiceTeam86@outlook.com



*You will need:

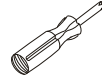

Phillips screwdriver

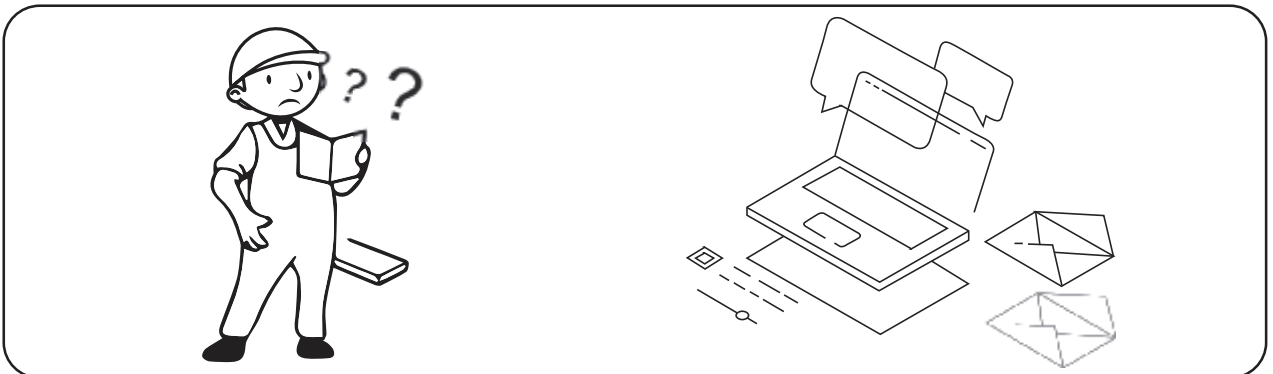
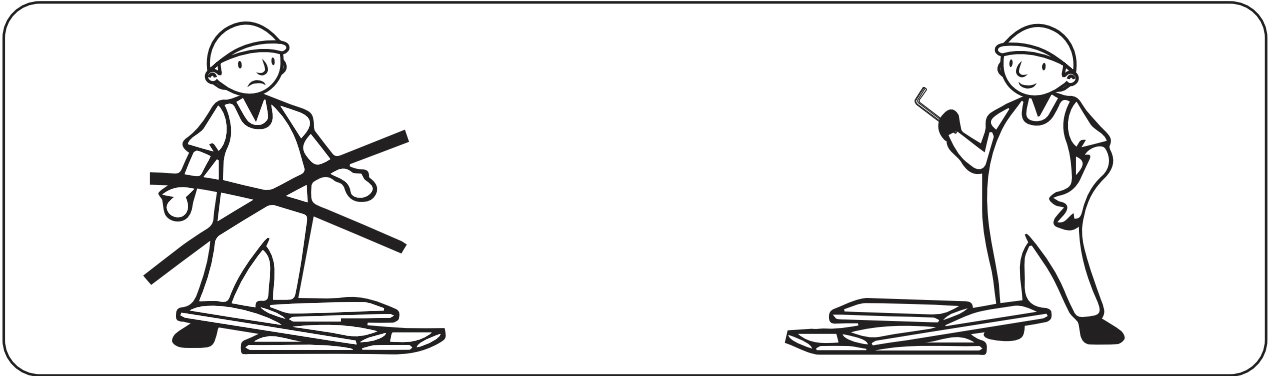

PARTS

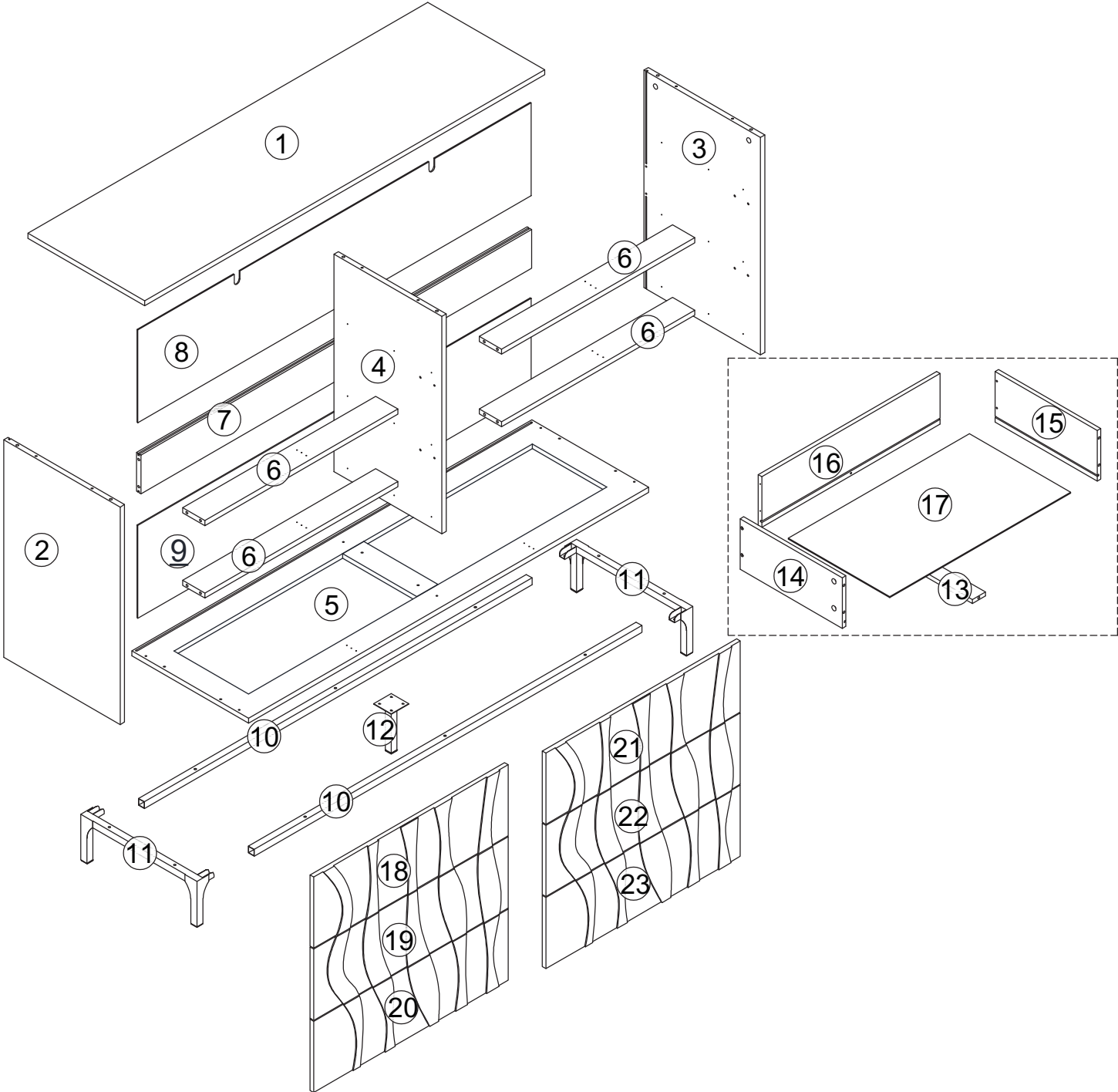

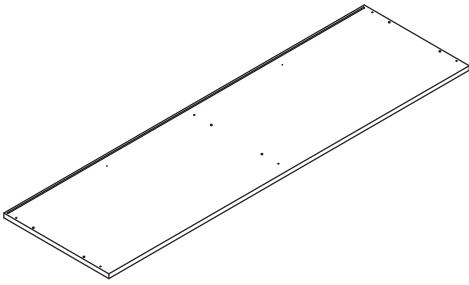

① x 1PC

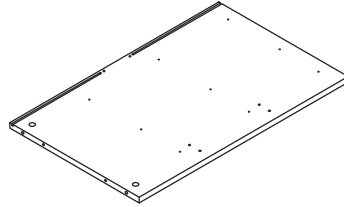

② x 1PC

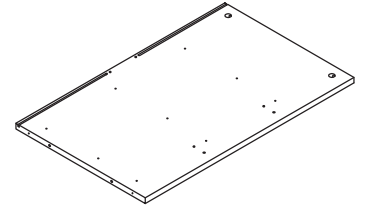

③ x 1PC

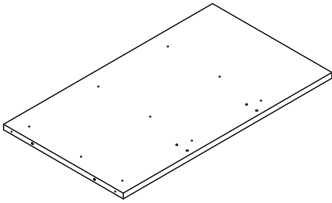

④ x 1PC

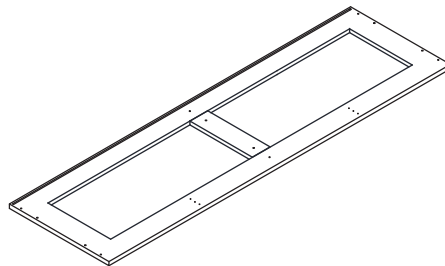

⑤ x 1PC

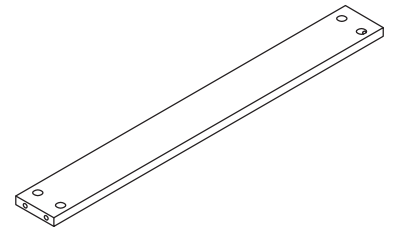

⑥ x 4PCS

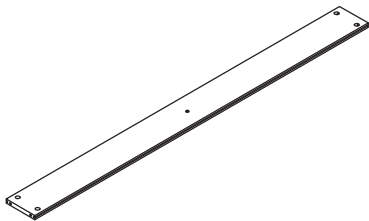

⑦ x 1PC

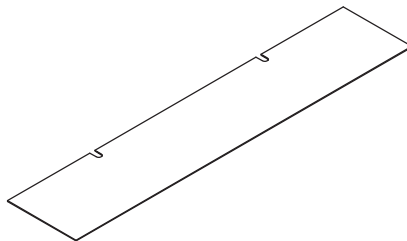

⑧ x 1PC

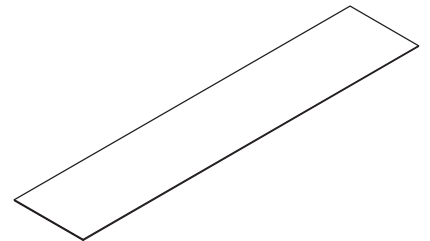

⑨ x 1PC

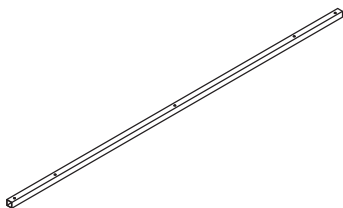

⑩ x 2PCS

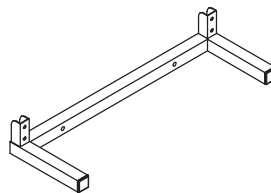

⑪ x 2PCS

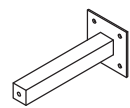

⑫ x 1PC

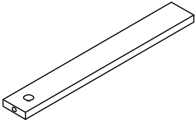

13 x 6PCS

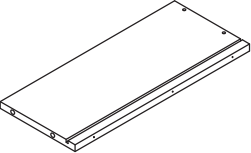

14 x 6PCS

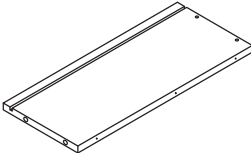

15 x 6PCS

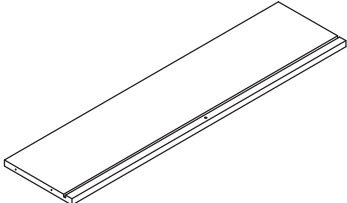

16 x 6PCS

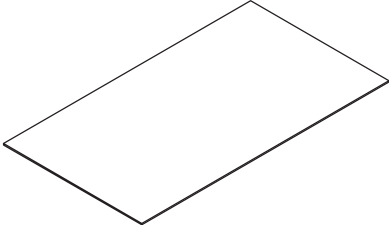

17 x 6PCS

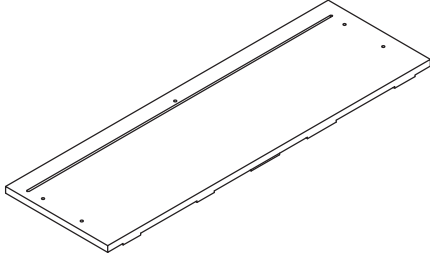

18 x 1PC

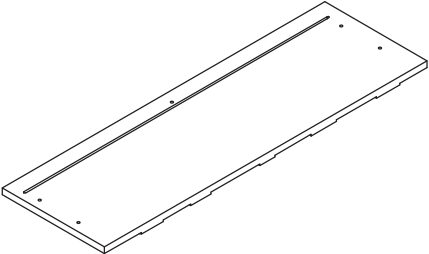

19 x 1PC

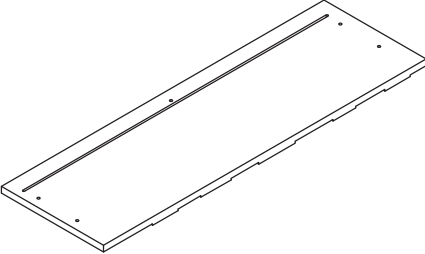

20 x 1PC

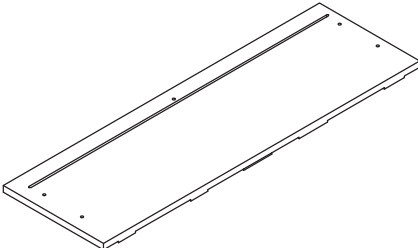

21 x 1PC

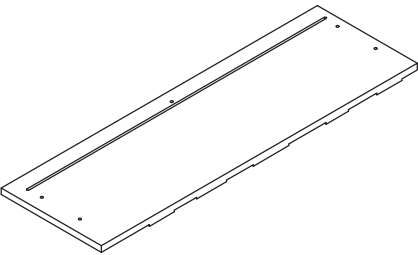

22 x 1PC

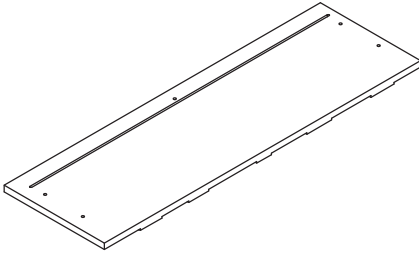

23 x 1PC

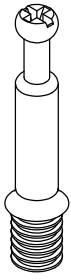

M6x35



M15x10

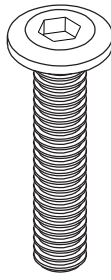

M6x30

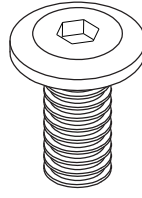

M6x14



M6x30

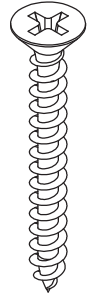

M4x35

A x48 +4 spare B x56 +4 spare C x10 +1 spare D x4 +1 spare E x14 +3 spare F x37 +3 spare



M3.5x12



M3x14



I x1

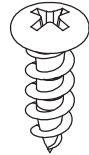

M4x14

J x6

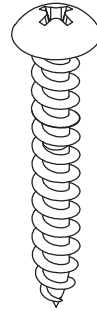

M4x40

K x2



L x6



Px4

G x90 +10 spare H x8 +1 spare

Scale 1:1



M x2



N x2

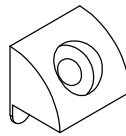

O x8 +1 spare

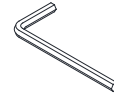

Q x1



R x48 +4 spare



L=300mm
CL x6



L=300mm
CR x6





L=300mm
DL x6



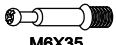

L=300mm
DR x6

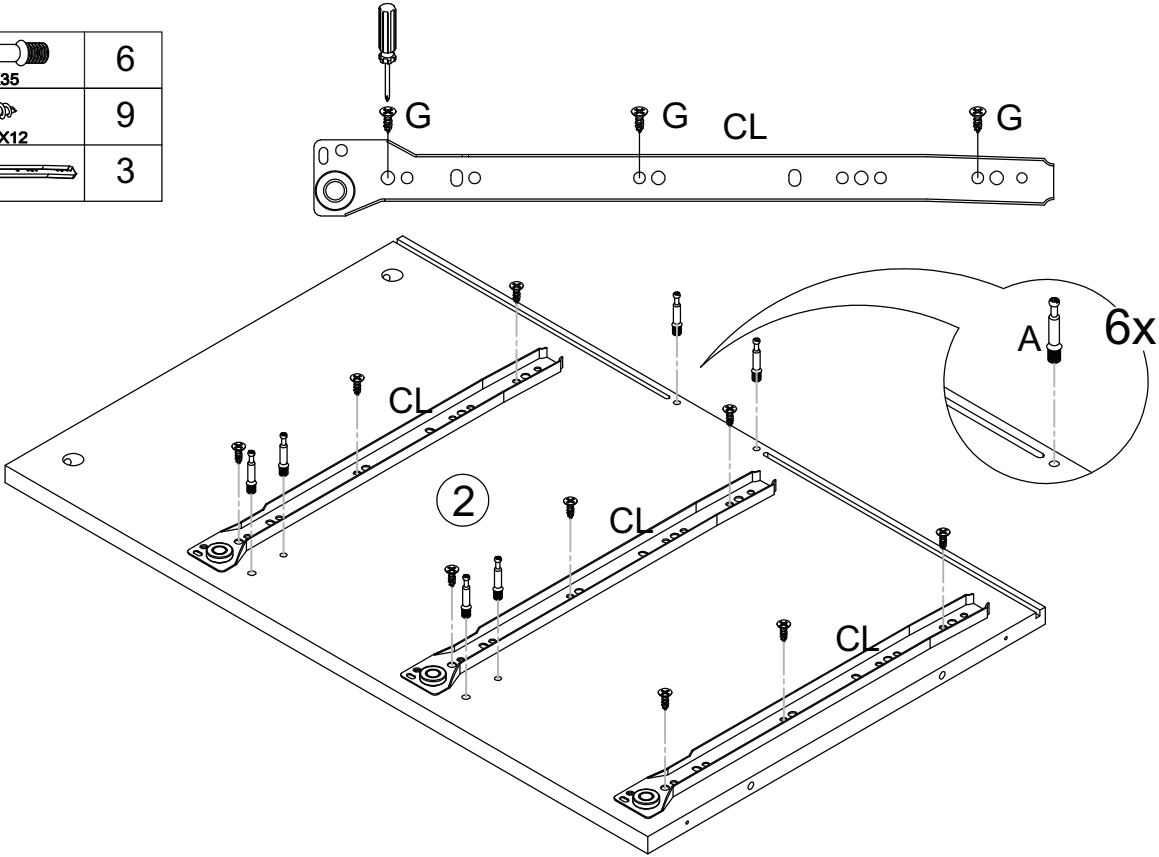

Note: Some screws include extra pieces for your convenience. Please keep them for future use.

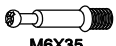
A	 M6X35	6
G	 M3.5X12	9
CL		3



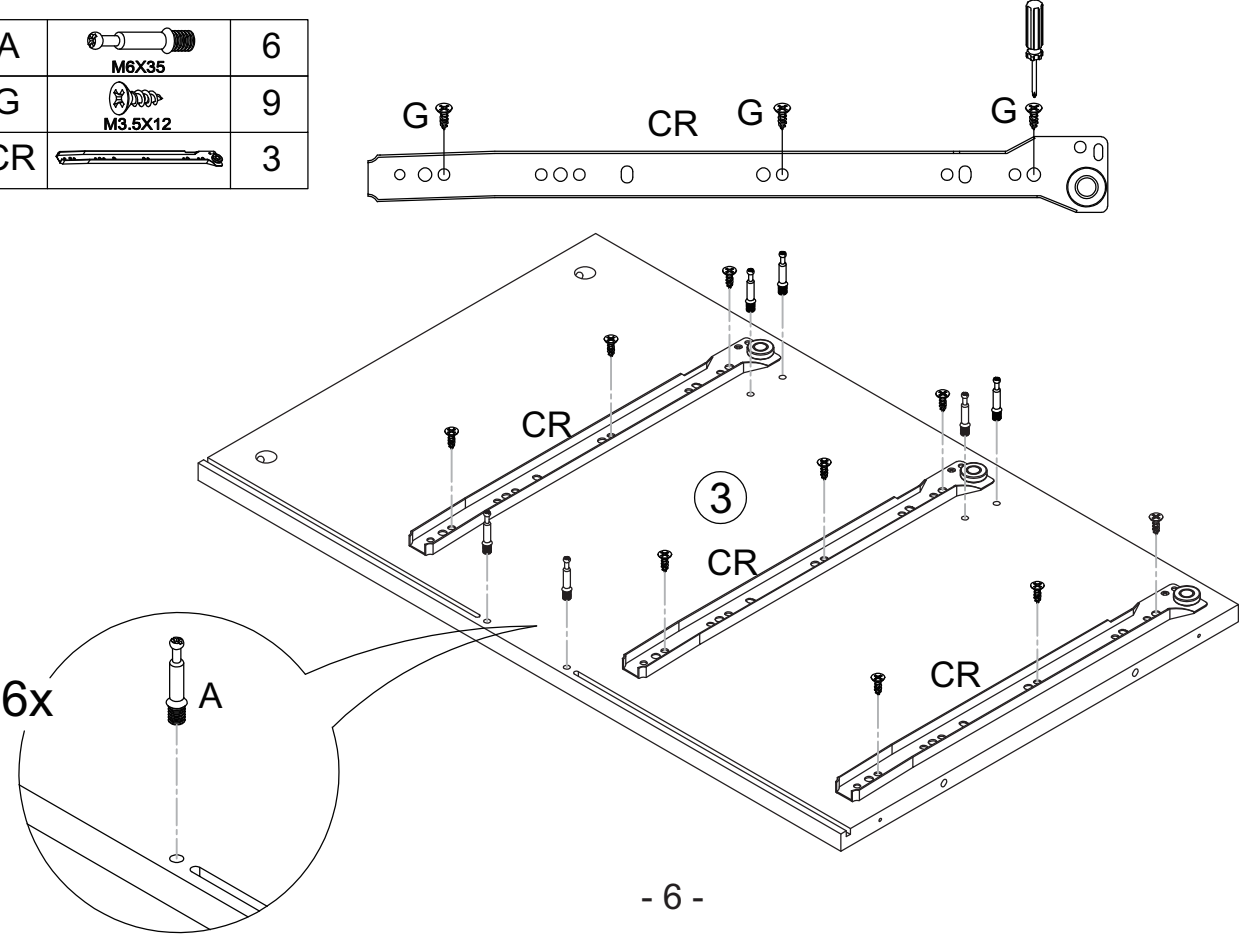

A	 M6X35	6
G	 M3.5X12	9
CR		3

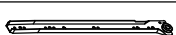

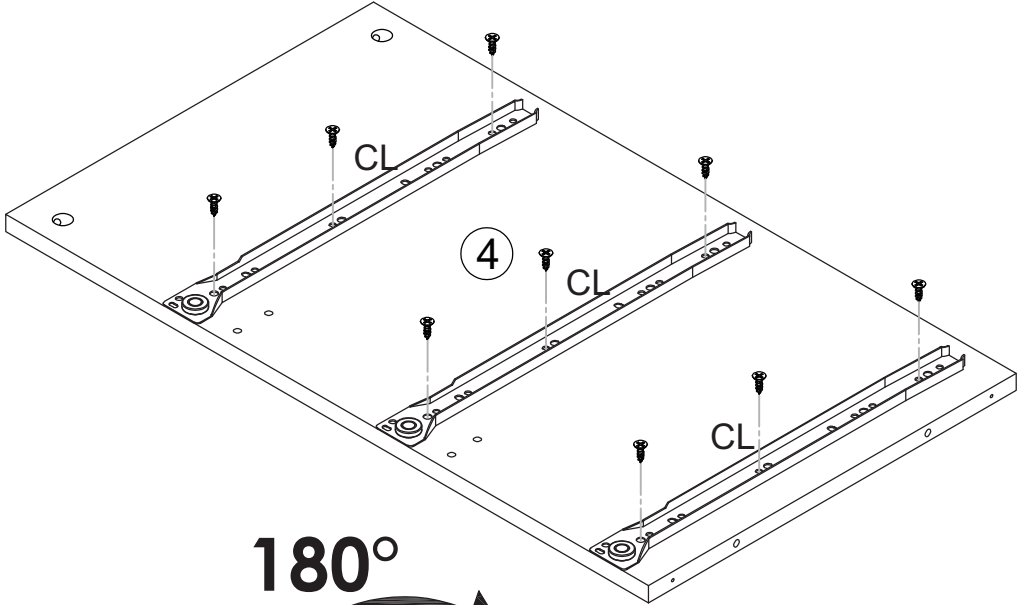
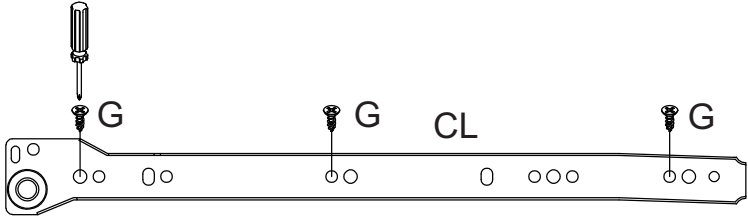
G	 M3.5X12	18
CL		3
CR		3

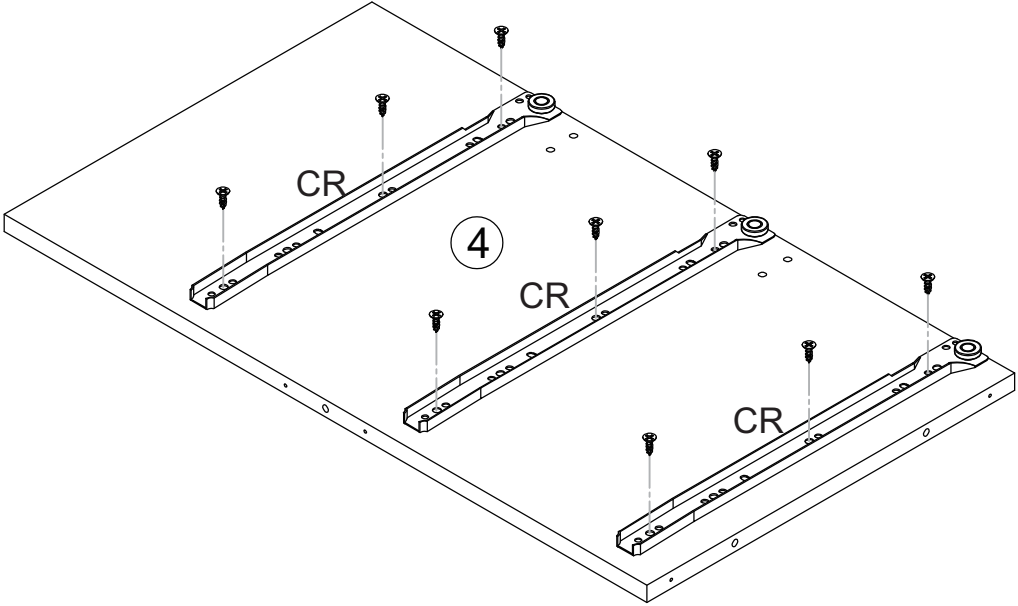
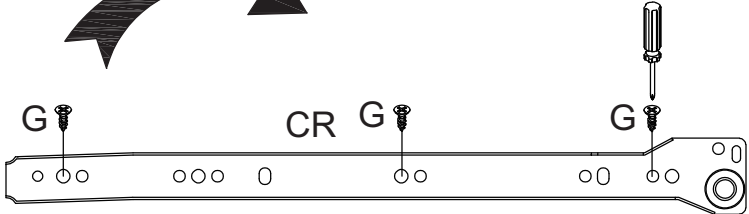

180°

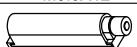

G	 M3.5X12	12
L		4

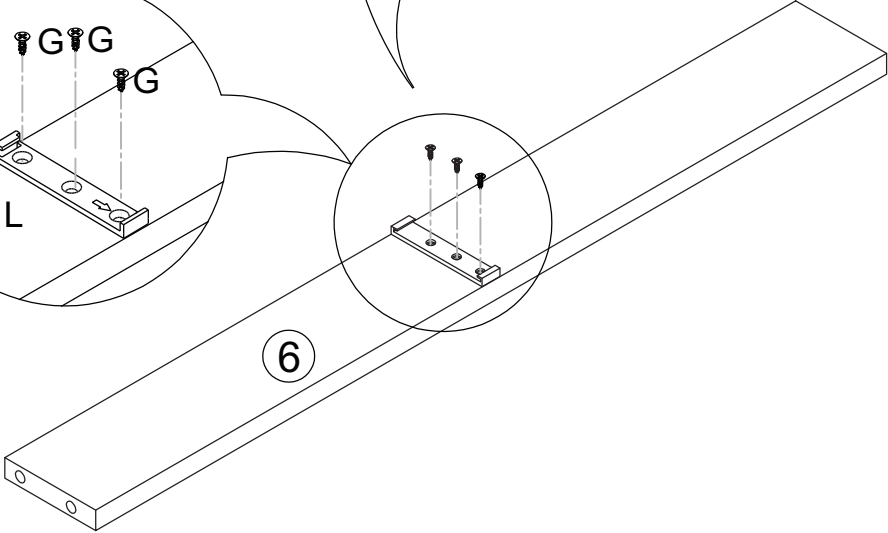
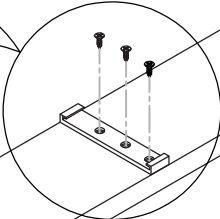
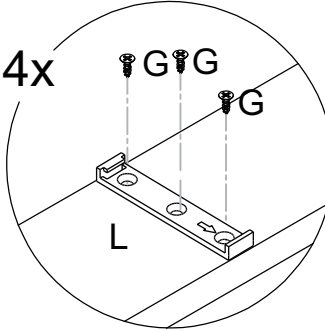
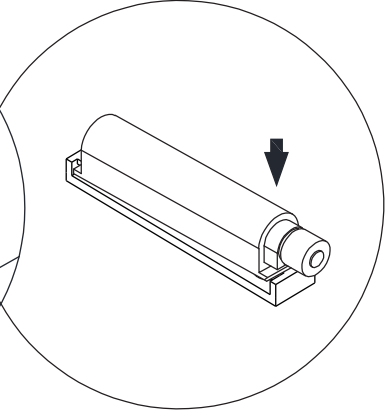
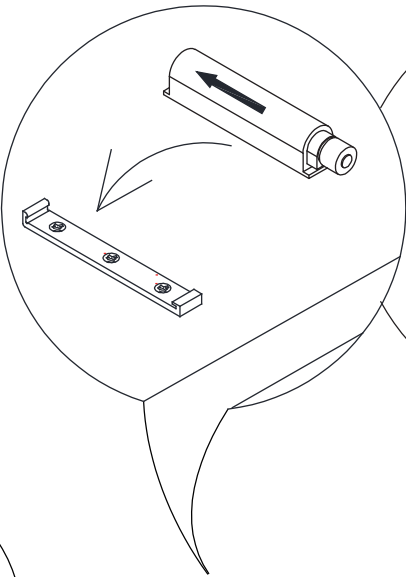
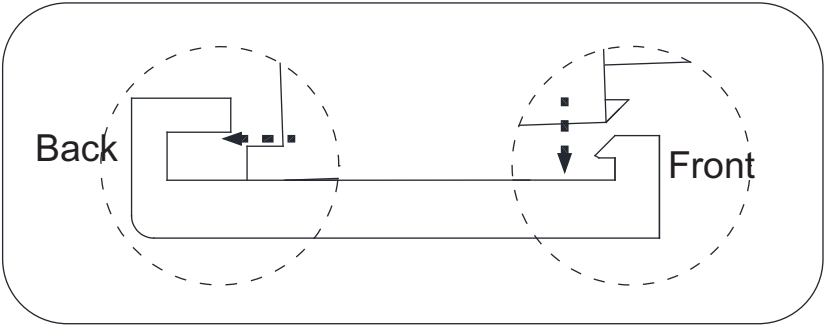

4x

B	 $\varnothing 15 \times 10$	4
P		4

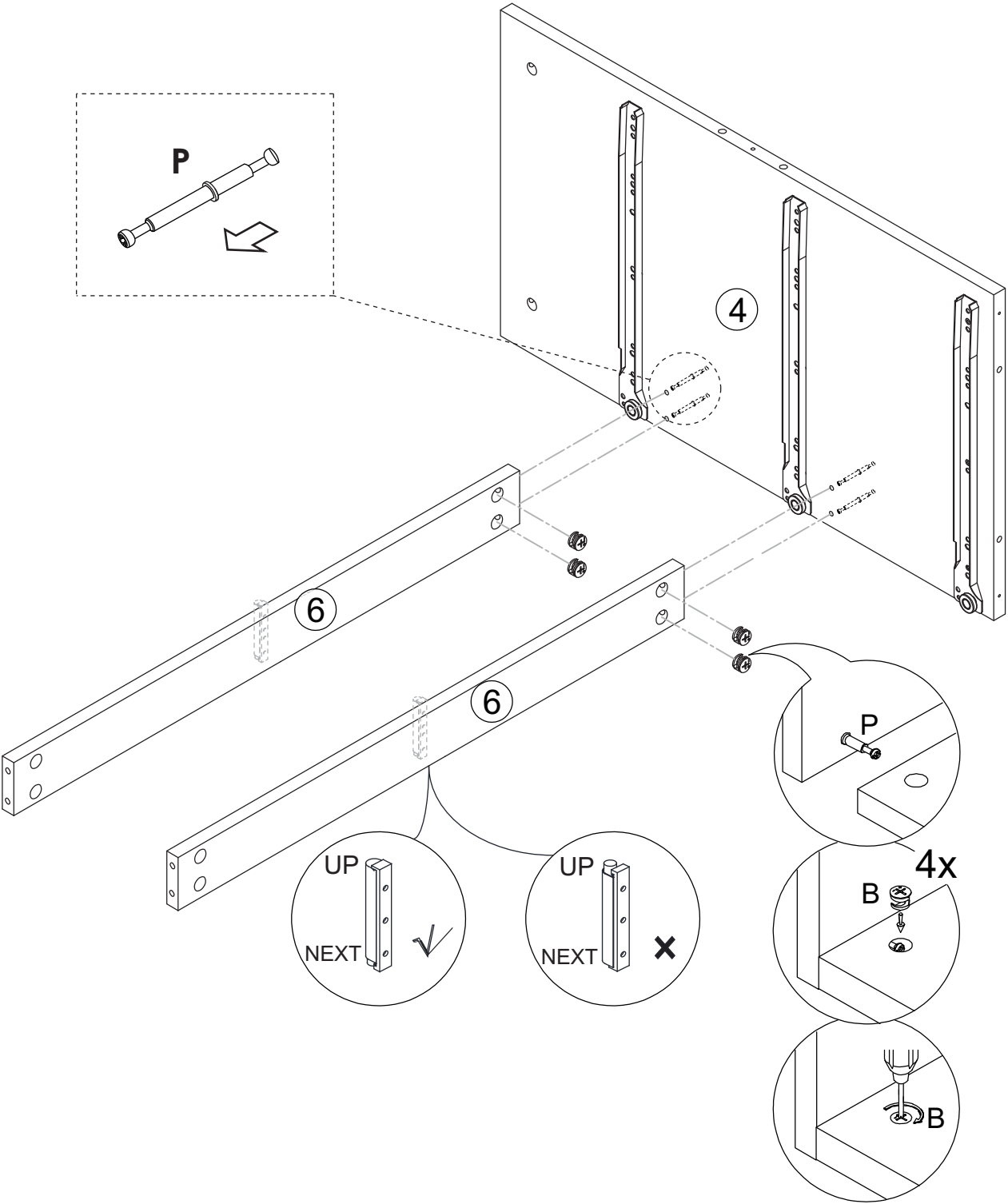

Insert the long bolt from the rear of Plate No.④, align it with the hole in the direction indicated in the diagram, and ensure careful handling to avoid impact or scratching.

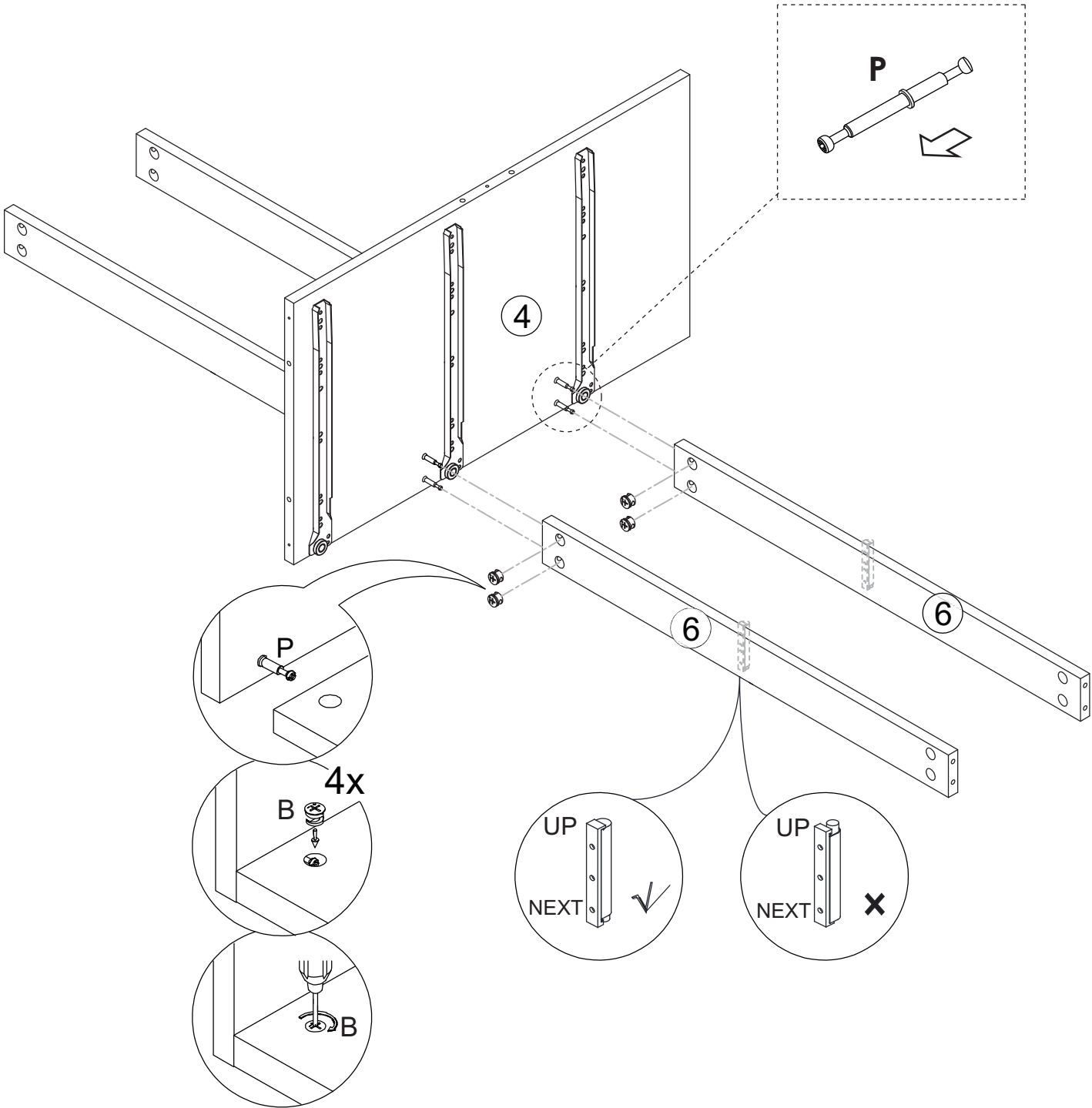

B	 Ø15X10	4
---	--	---

Mount the short bolt on the side of Plate No. ④ without the cam, and secure it in place.



E	 Ø6X30	2
F	 M4X35	1

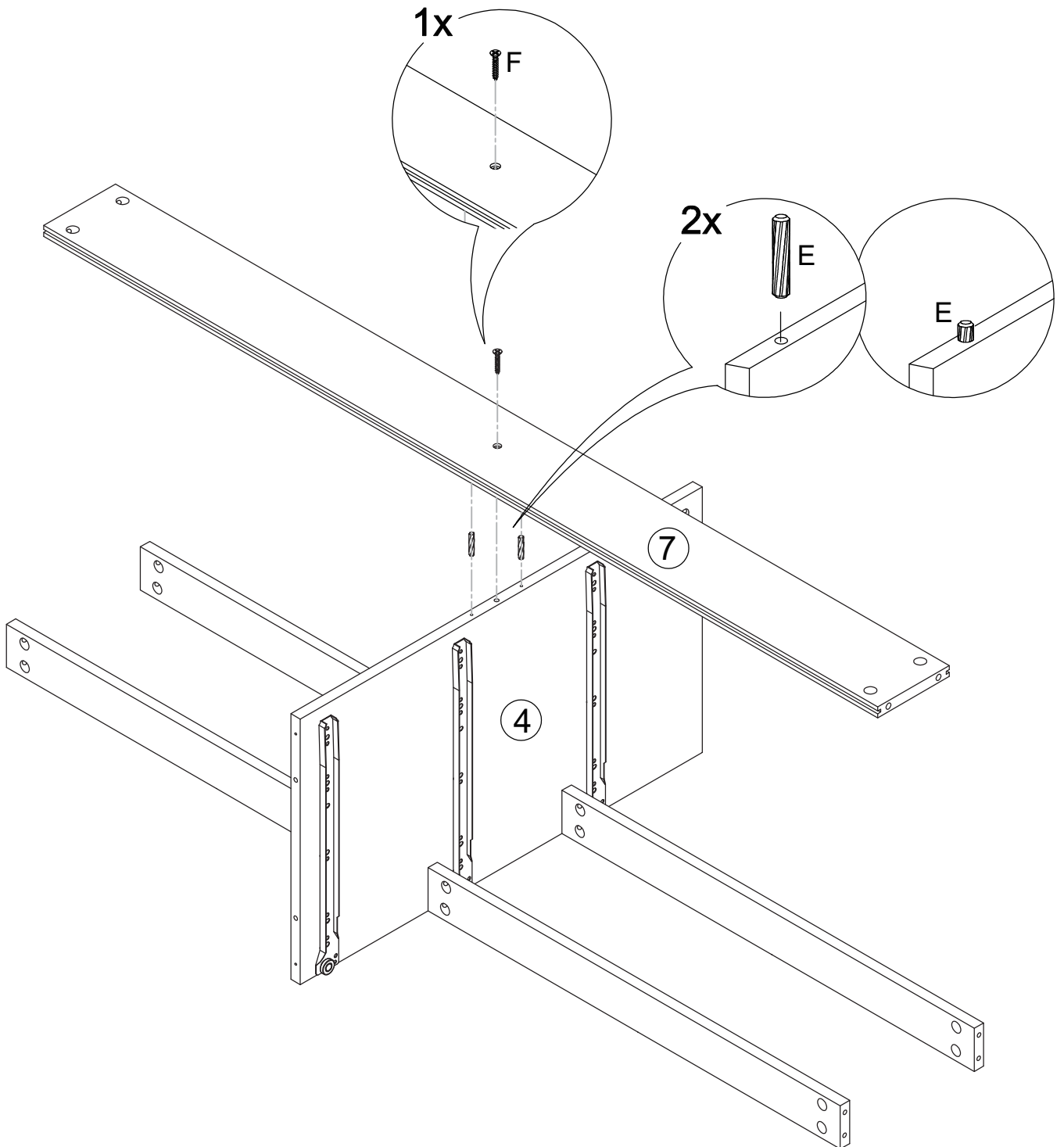

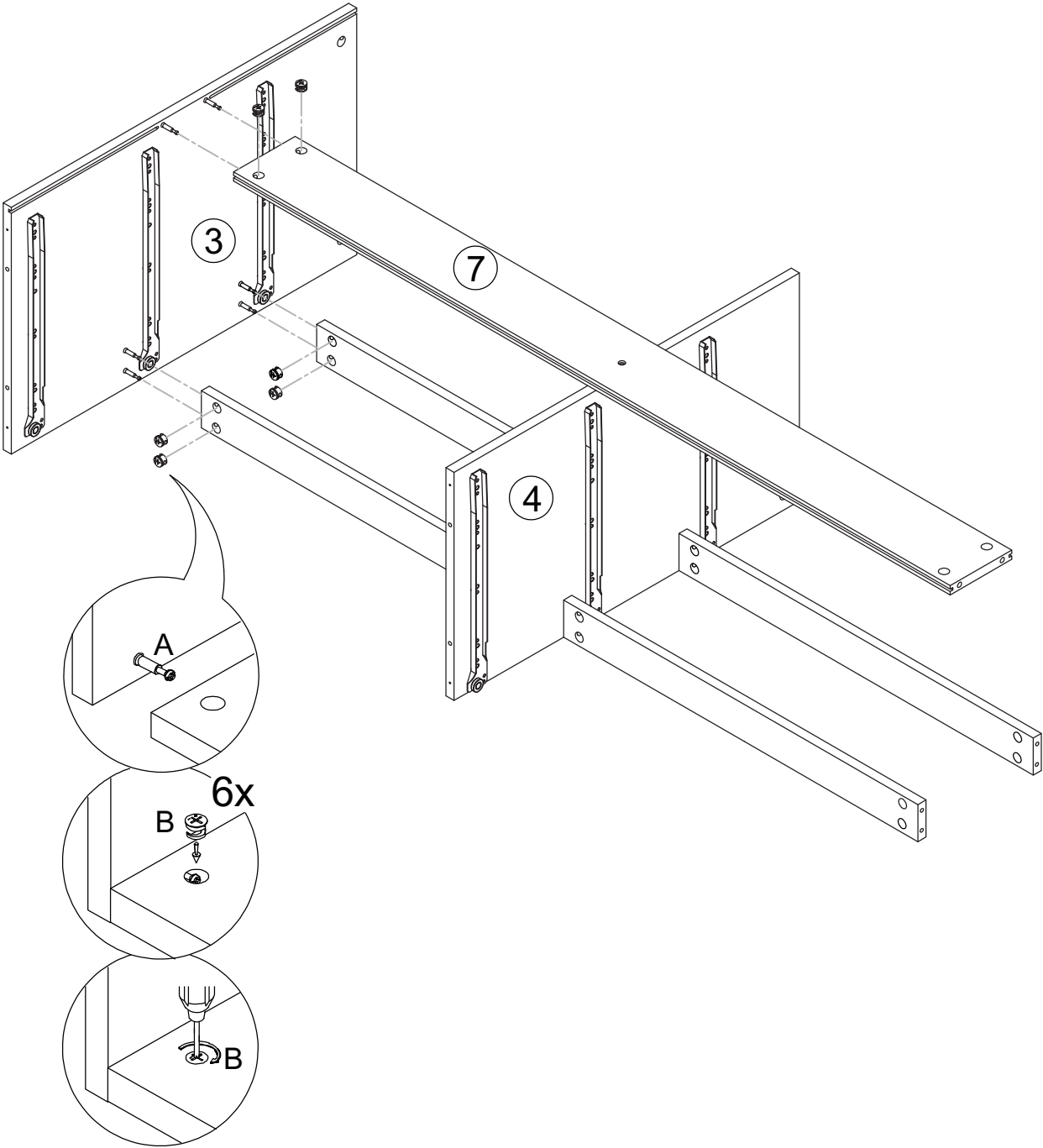

B	 Ø15X10	6
---	---	---

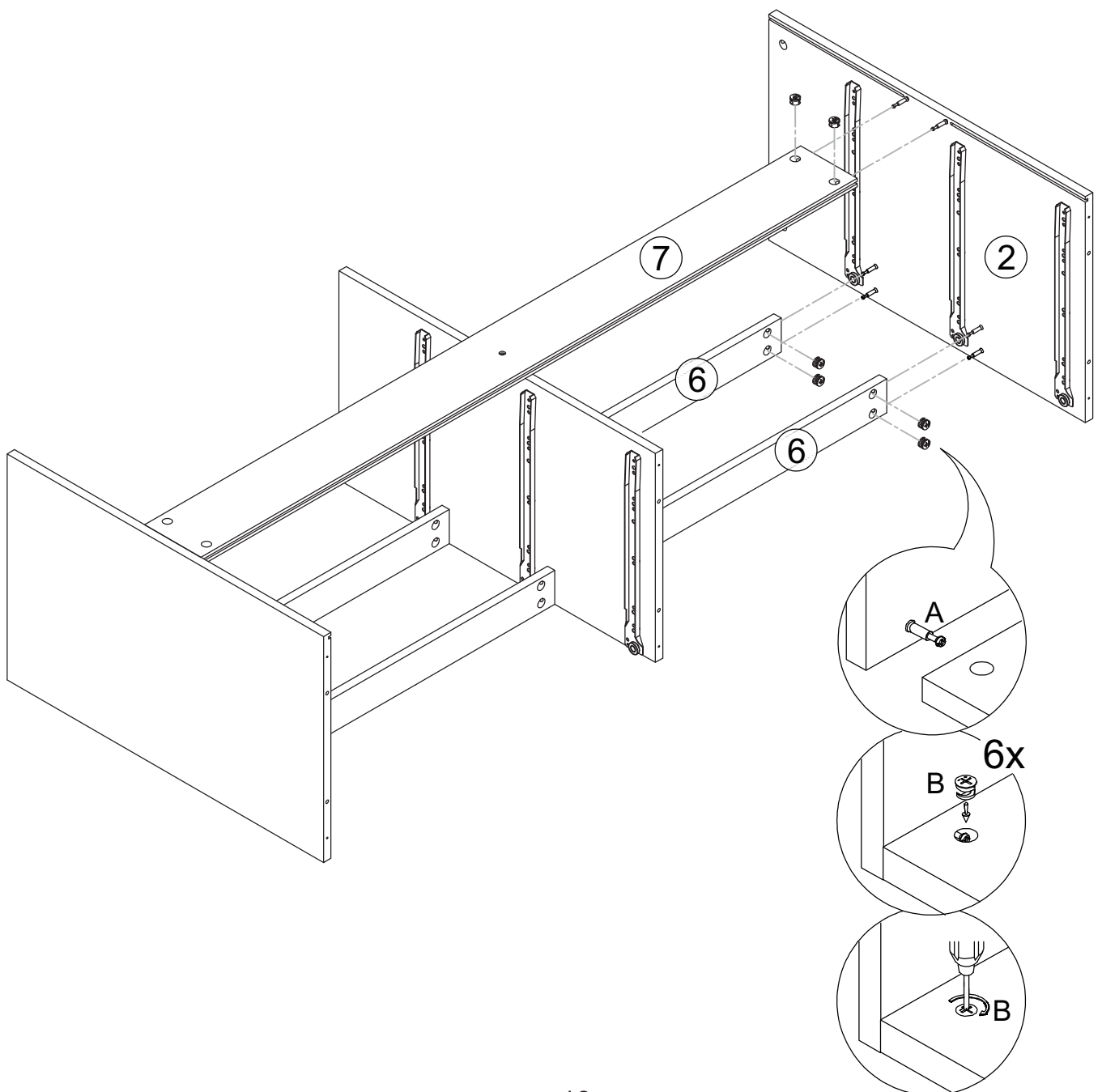

B	 Ø15X10	6
---	---	---

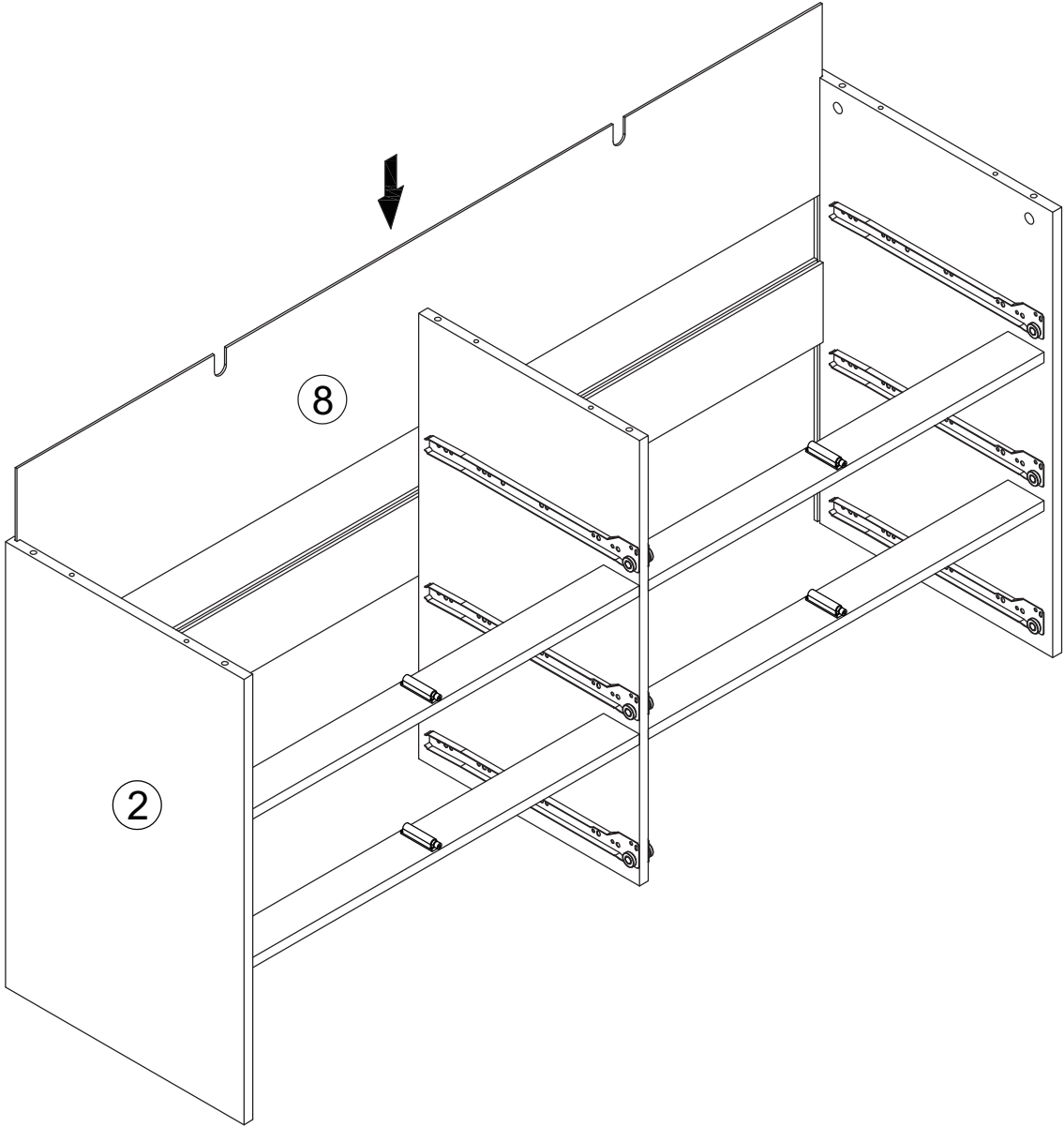

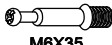



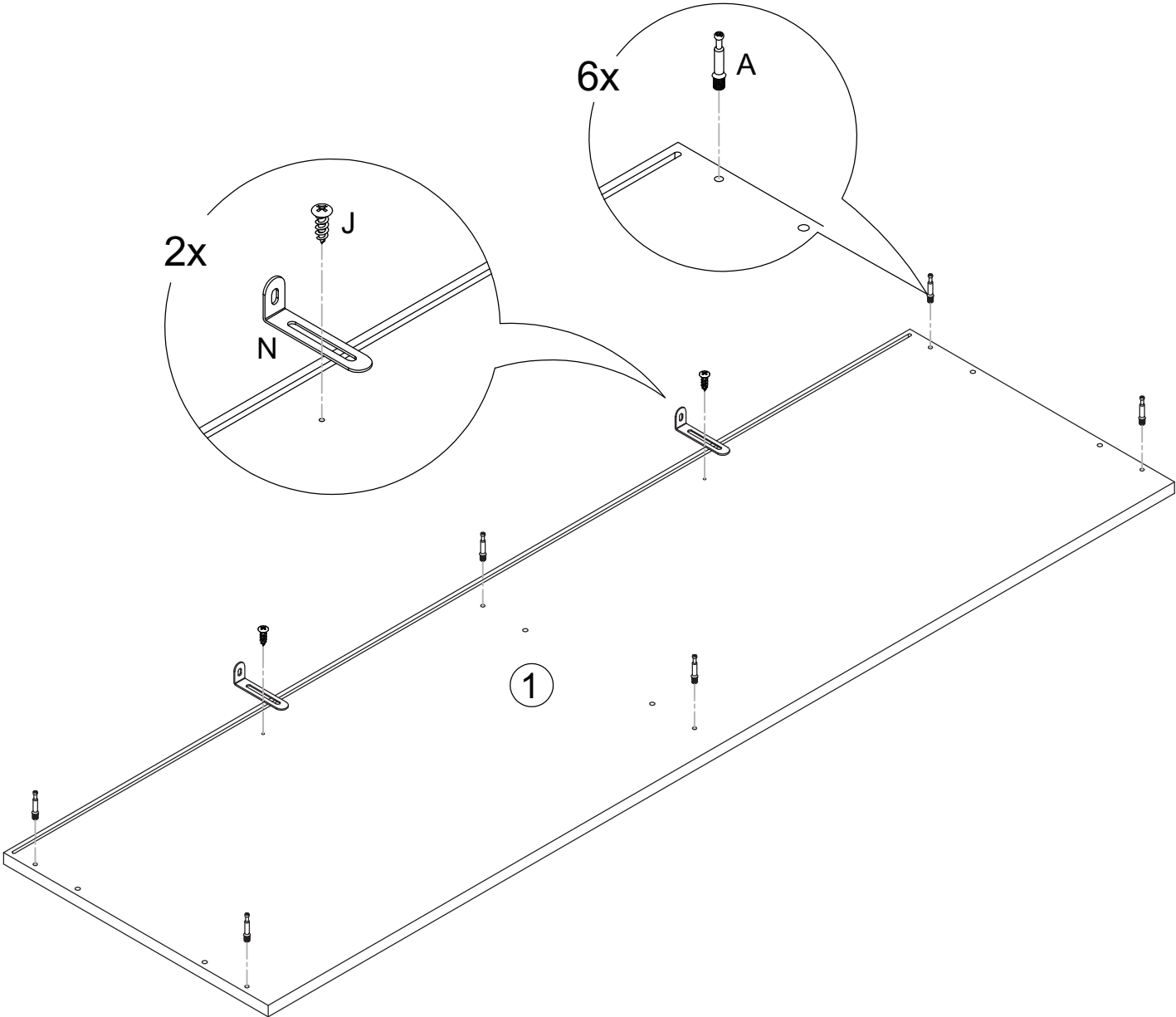

A	 M6X35	6
J	 M4X14	2
N		2

Lock the long side of the "N" L-shaped metal plate to the board with the "L" short screw



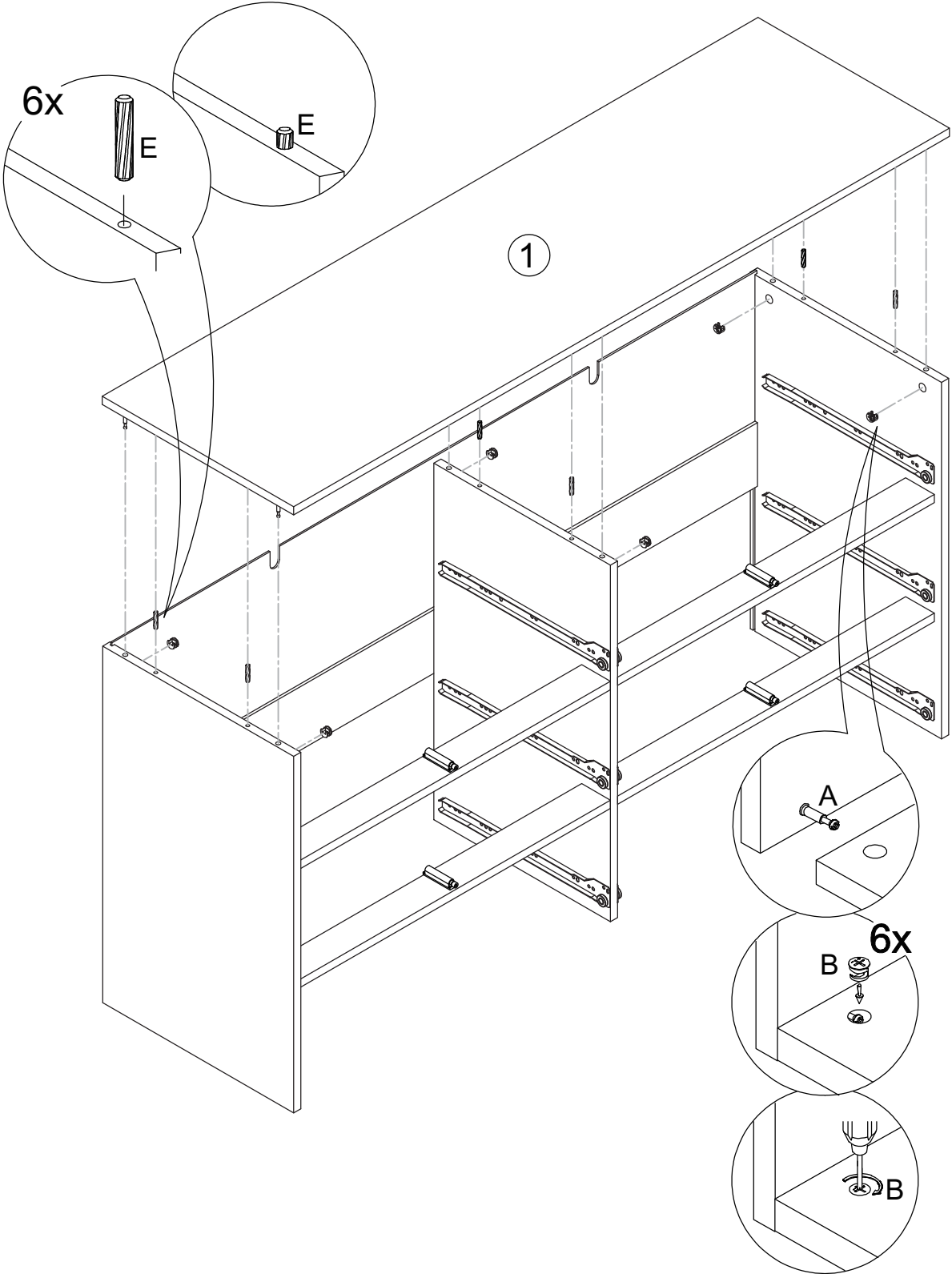

B	 Ø15X10	6
E	 Ø6X30	6

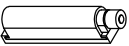

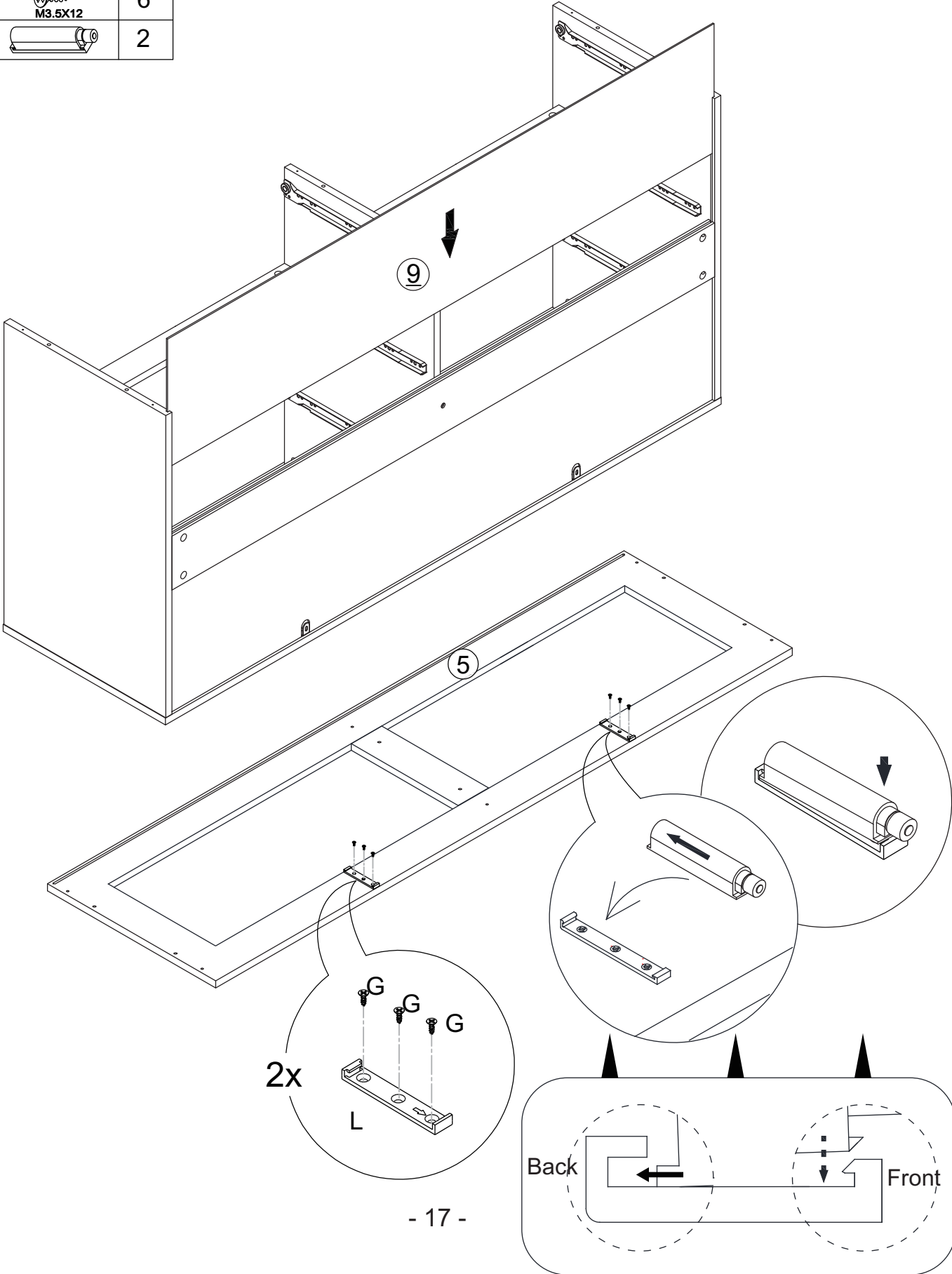
G	 M3.5X12	6
L		2





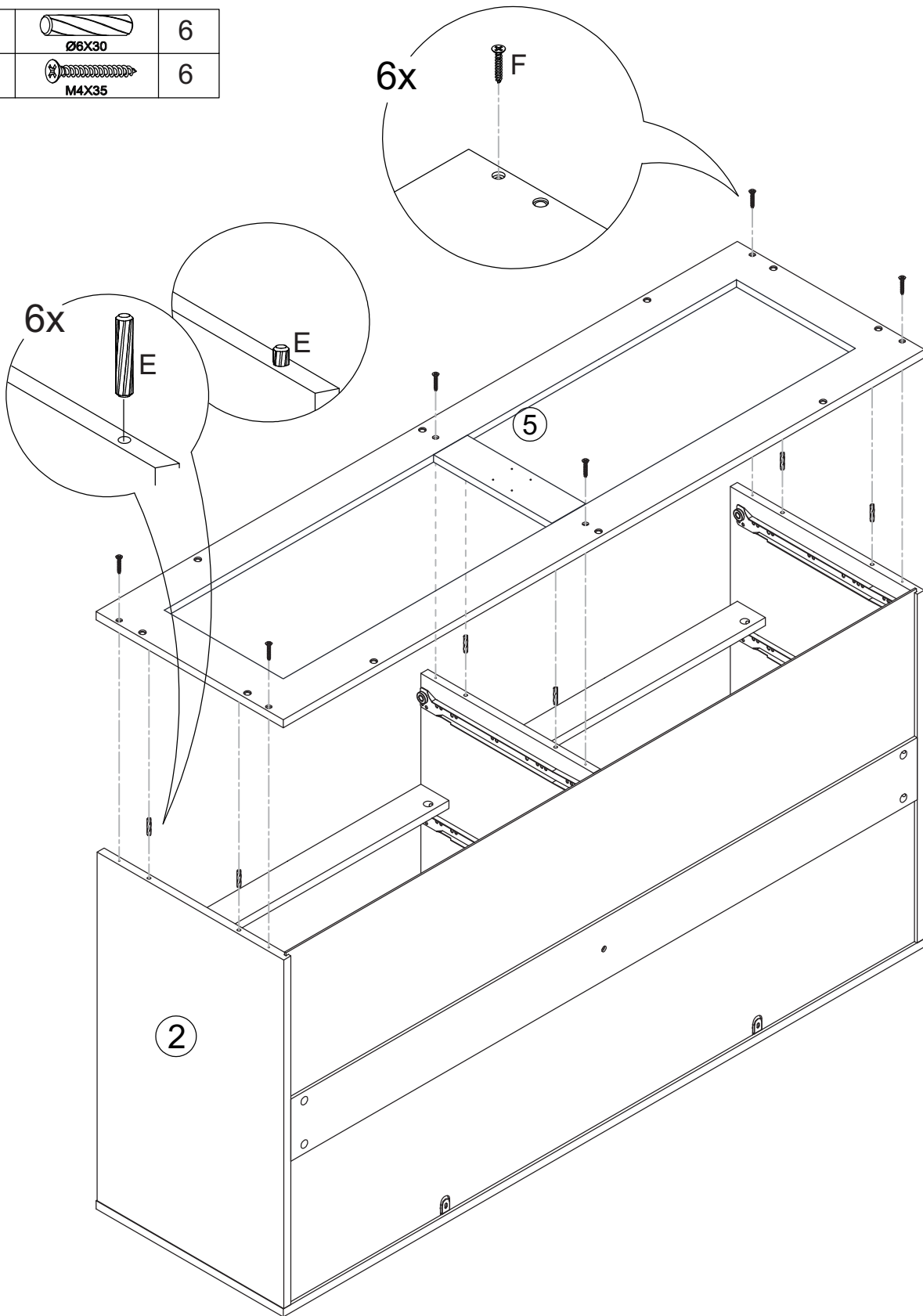

E	 Ø6X30	6
F	 M4X35	6

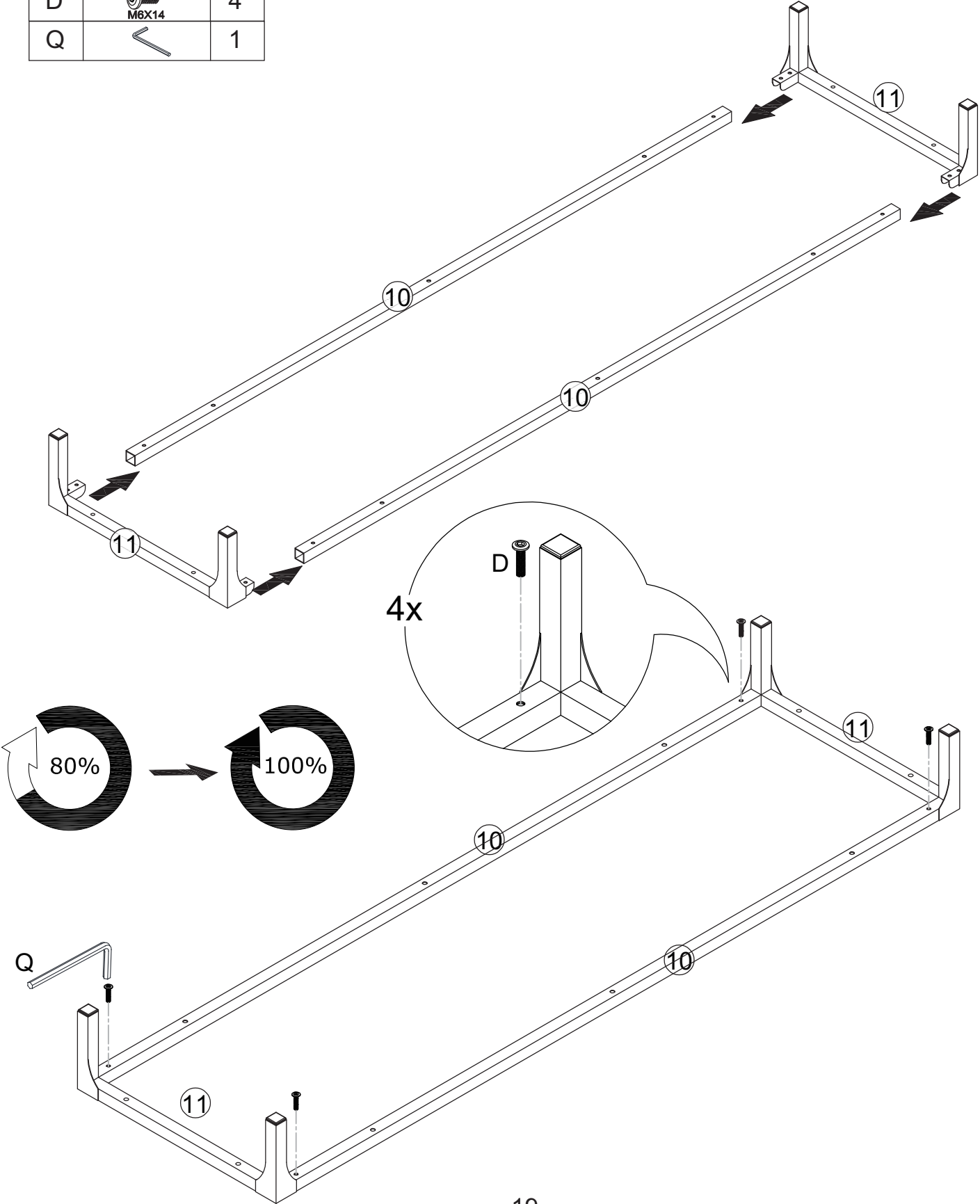



D	 M6x14	4
Q		1

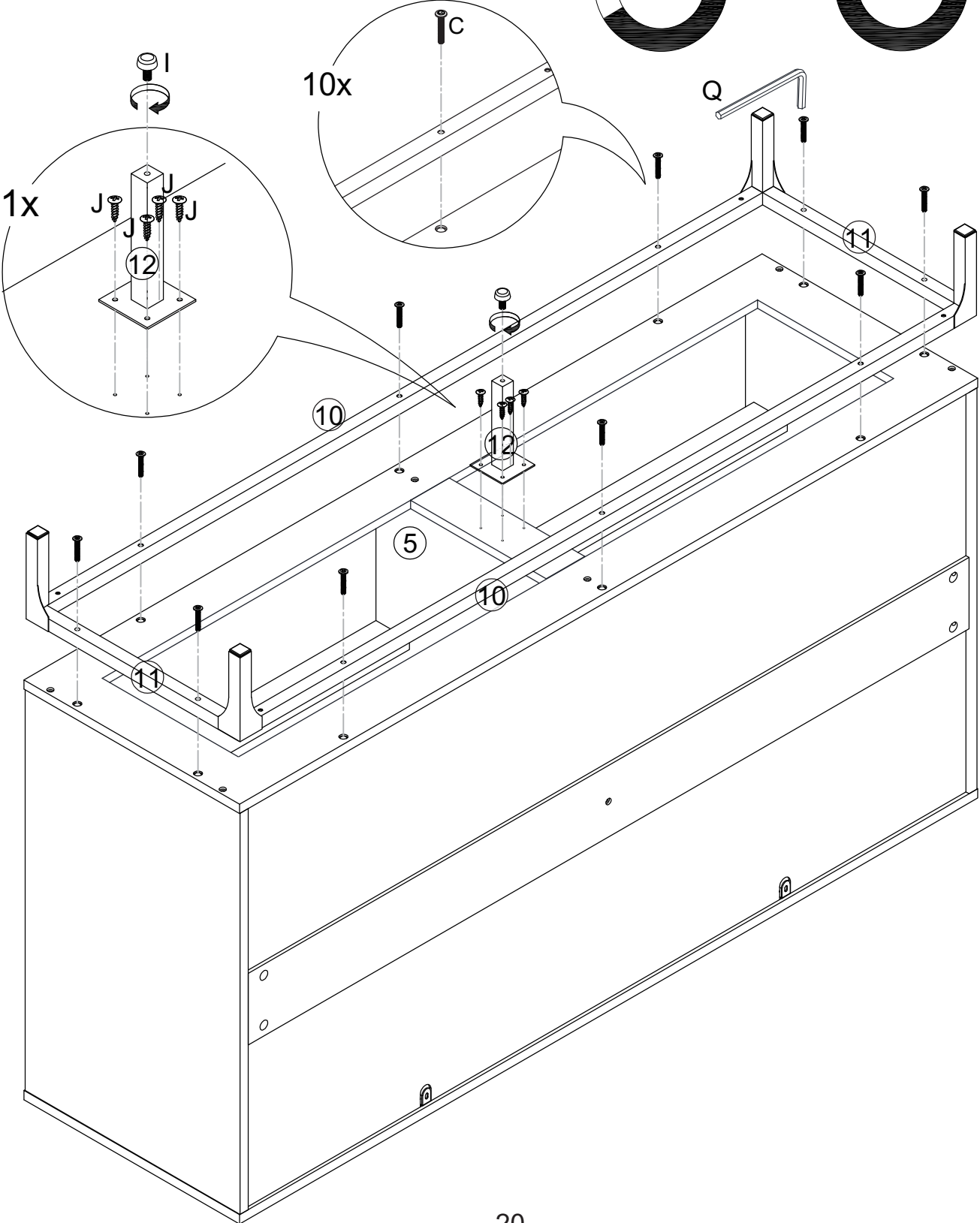
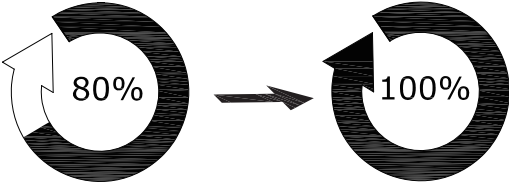

C	 M6X30	10	Q		1
J	 M4X14	4	I		1



H	 M3X14	8
O		8

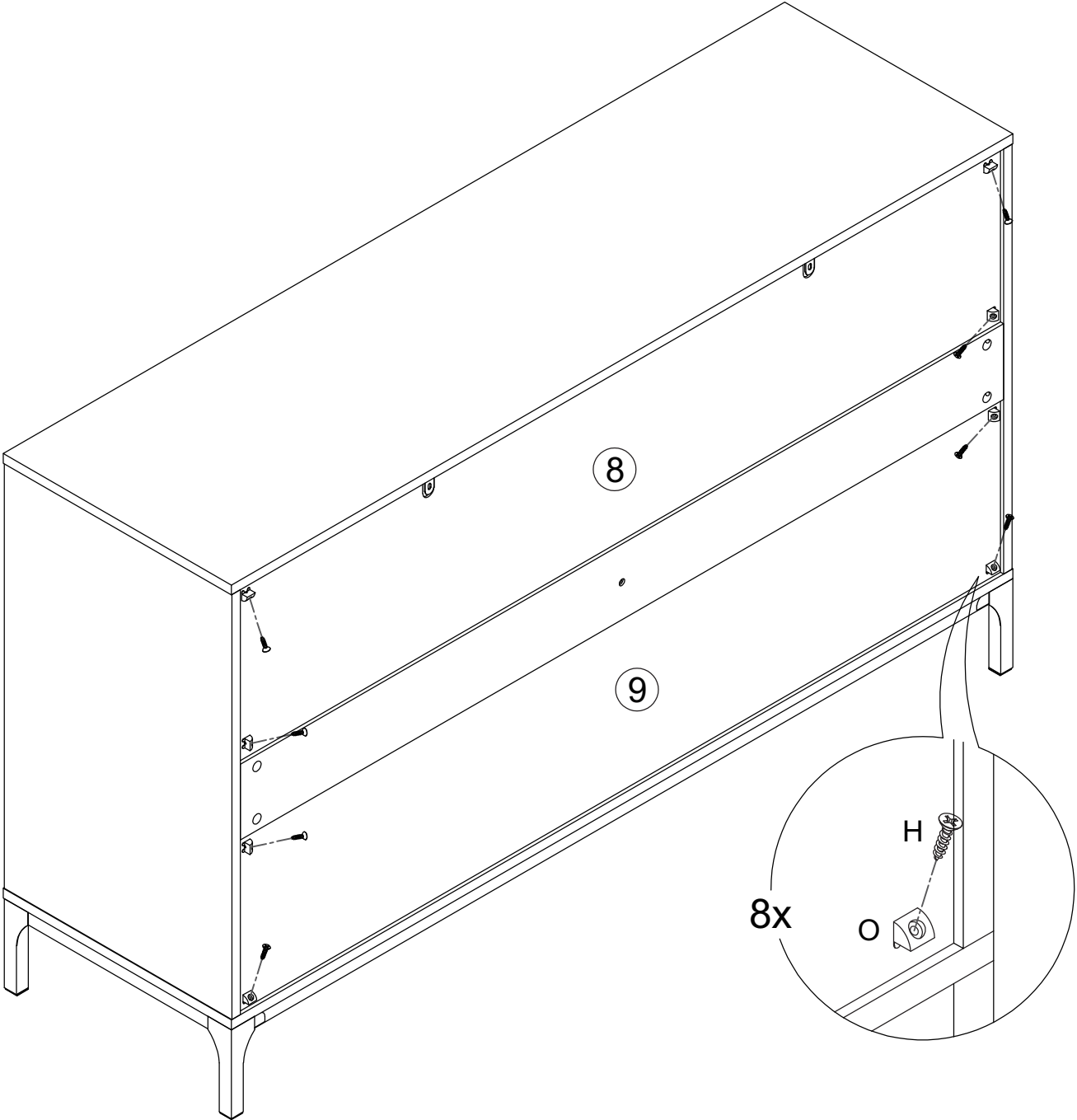

M		2
---	---	---

Drill 2 holes on the wall at the required position for anti-falling device installation.

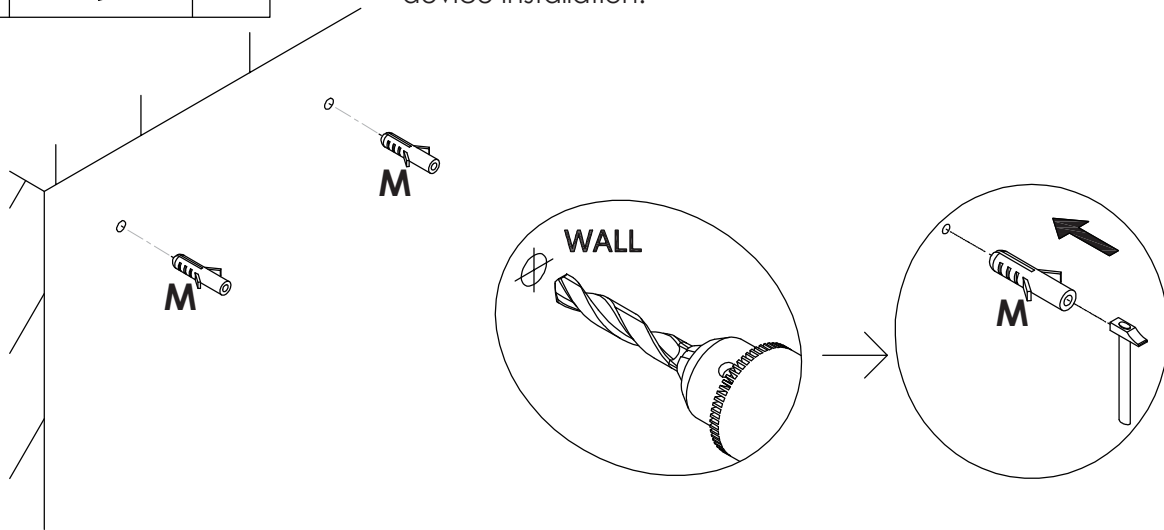

K	 M4X40	2
---	--	---

Move the cabinet to the required position, use the "K" long screw to fix the cabinet to the wall.

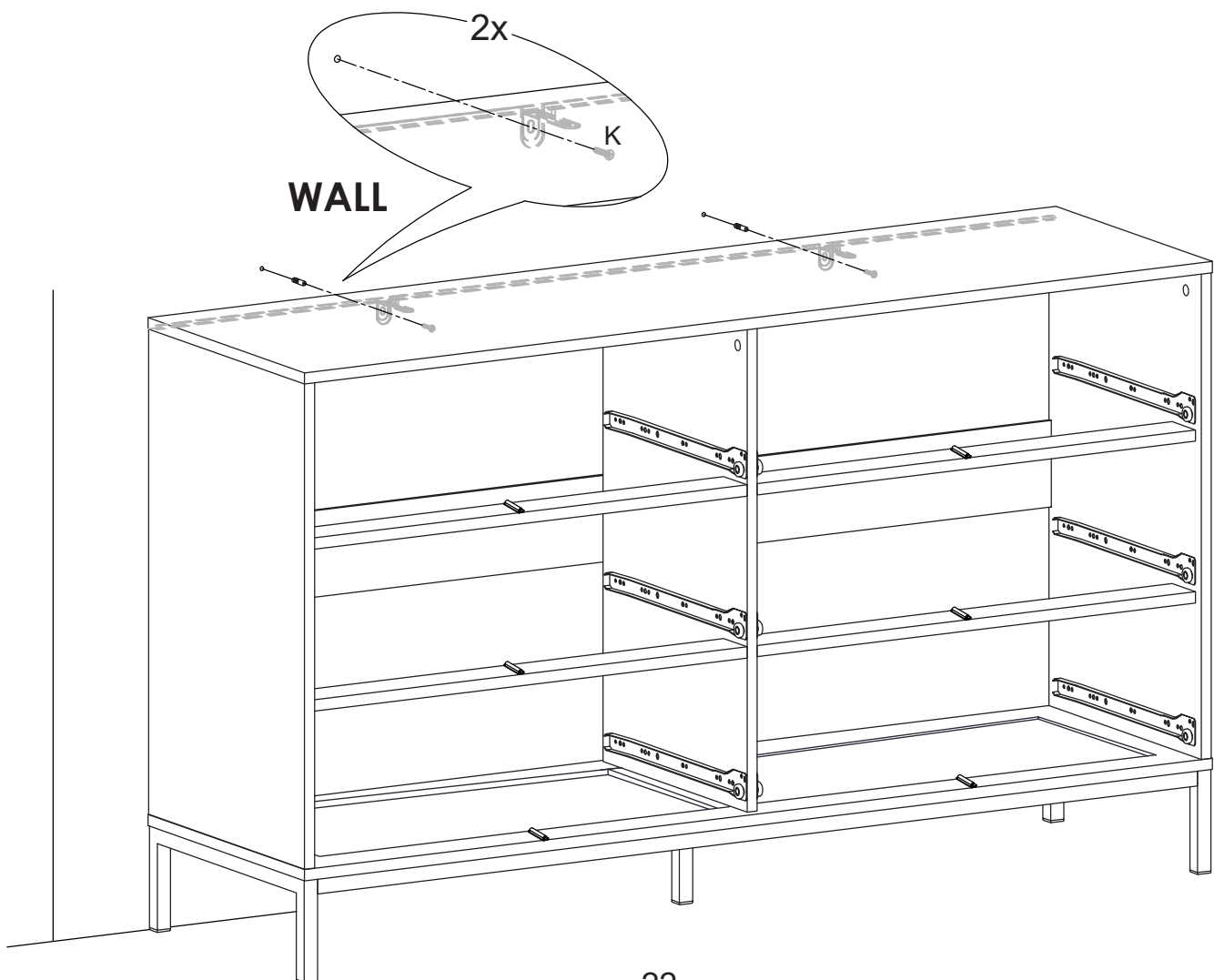

F	 M4X35	30
---	--	----

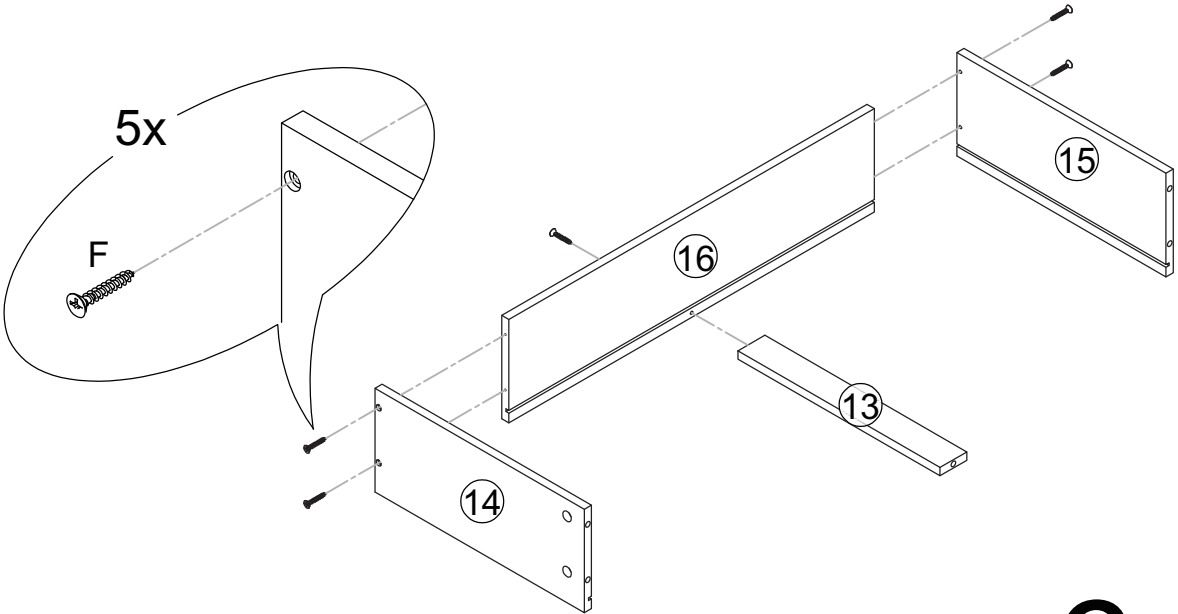

6x

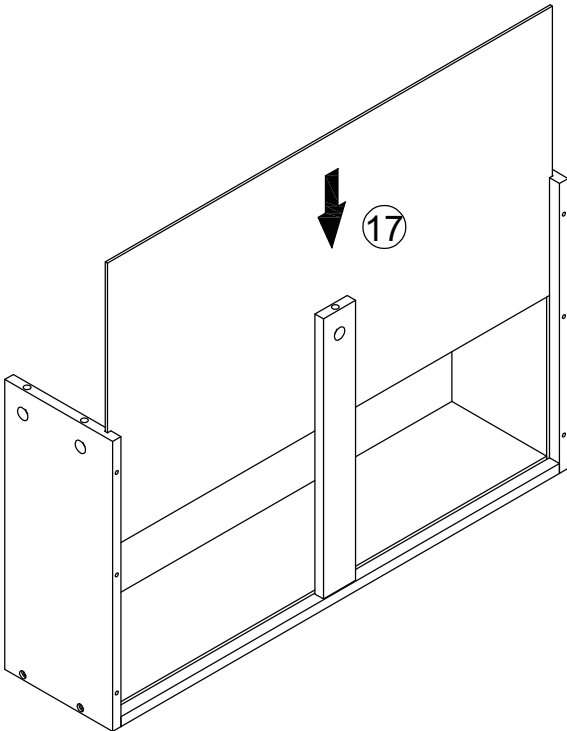



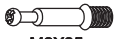

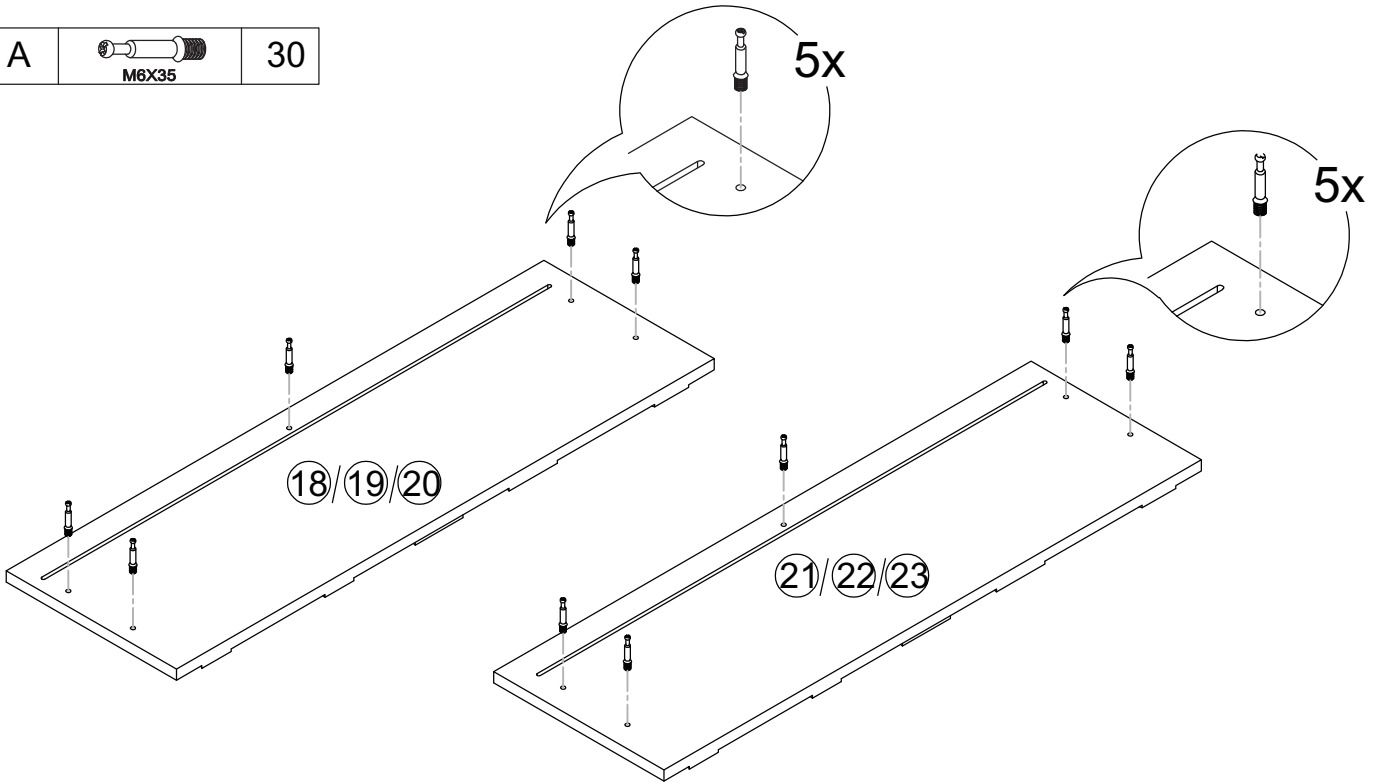
6x

A	 M6X35	30
---	--	----

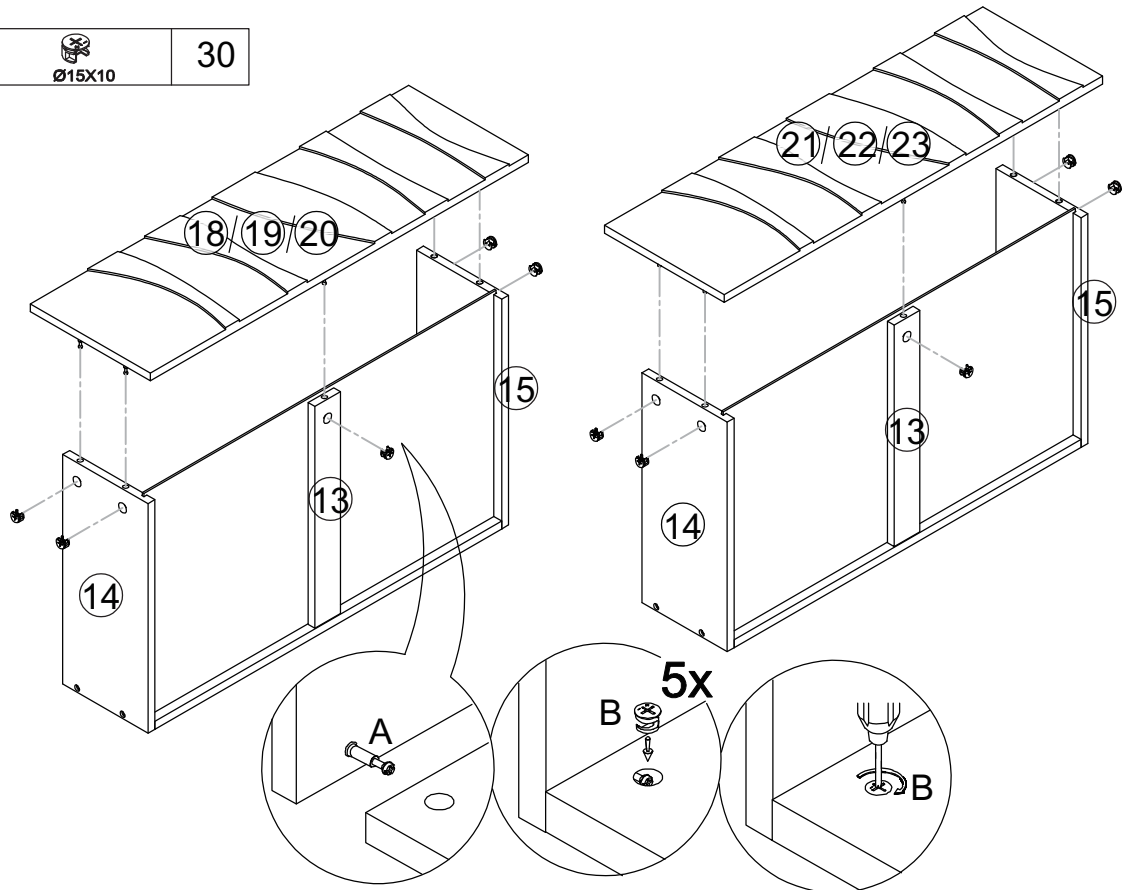



B	 Ø15X10	30
---	---	----

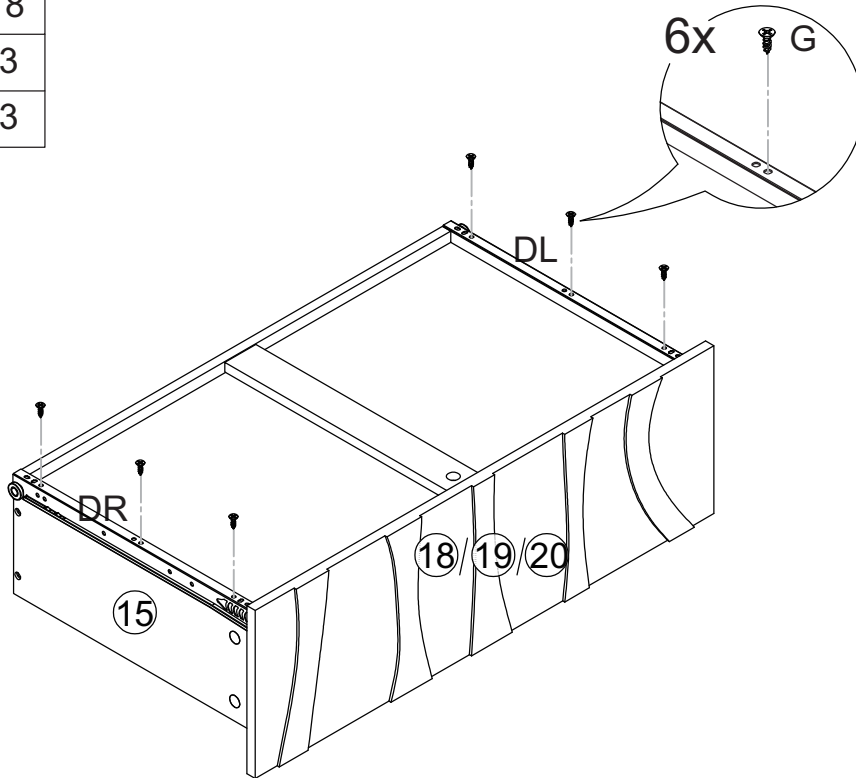

G	 M3.5X12	18
DL		3
DR		3



G	 M3.5X12	18
DL		3
DR		3

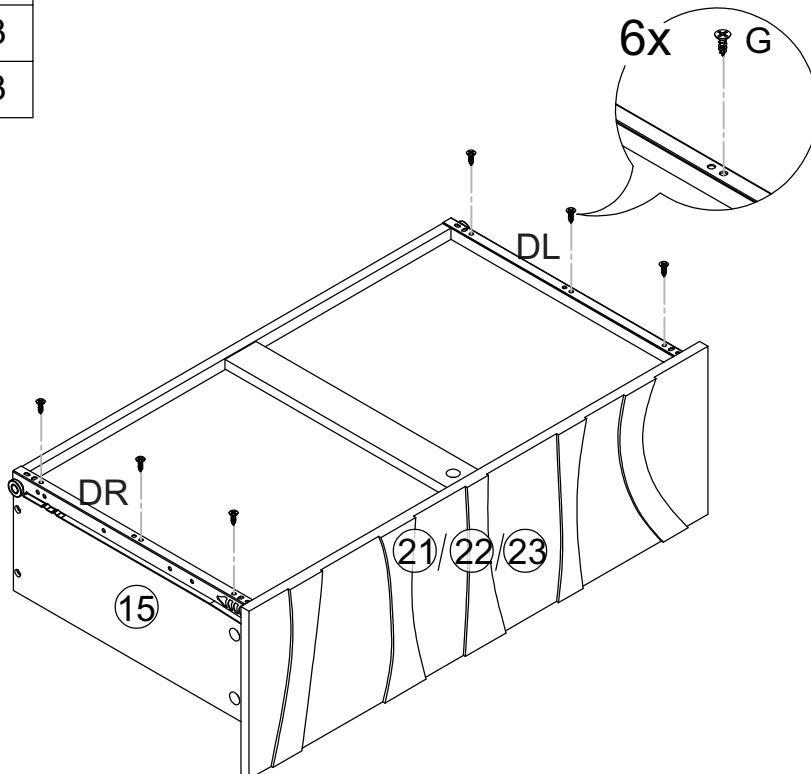

R		48
---	---	----

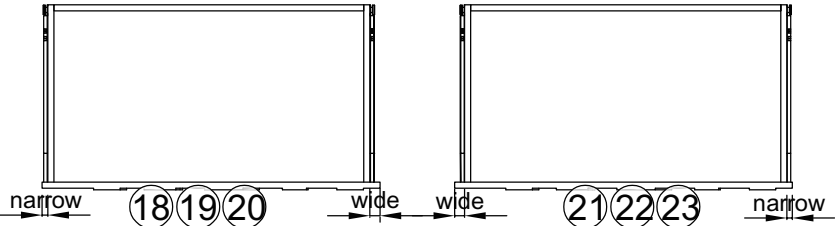
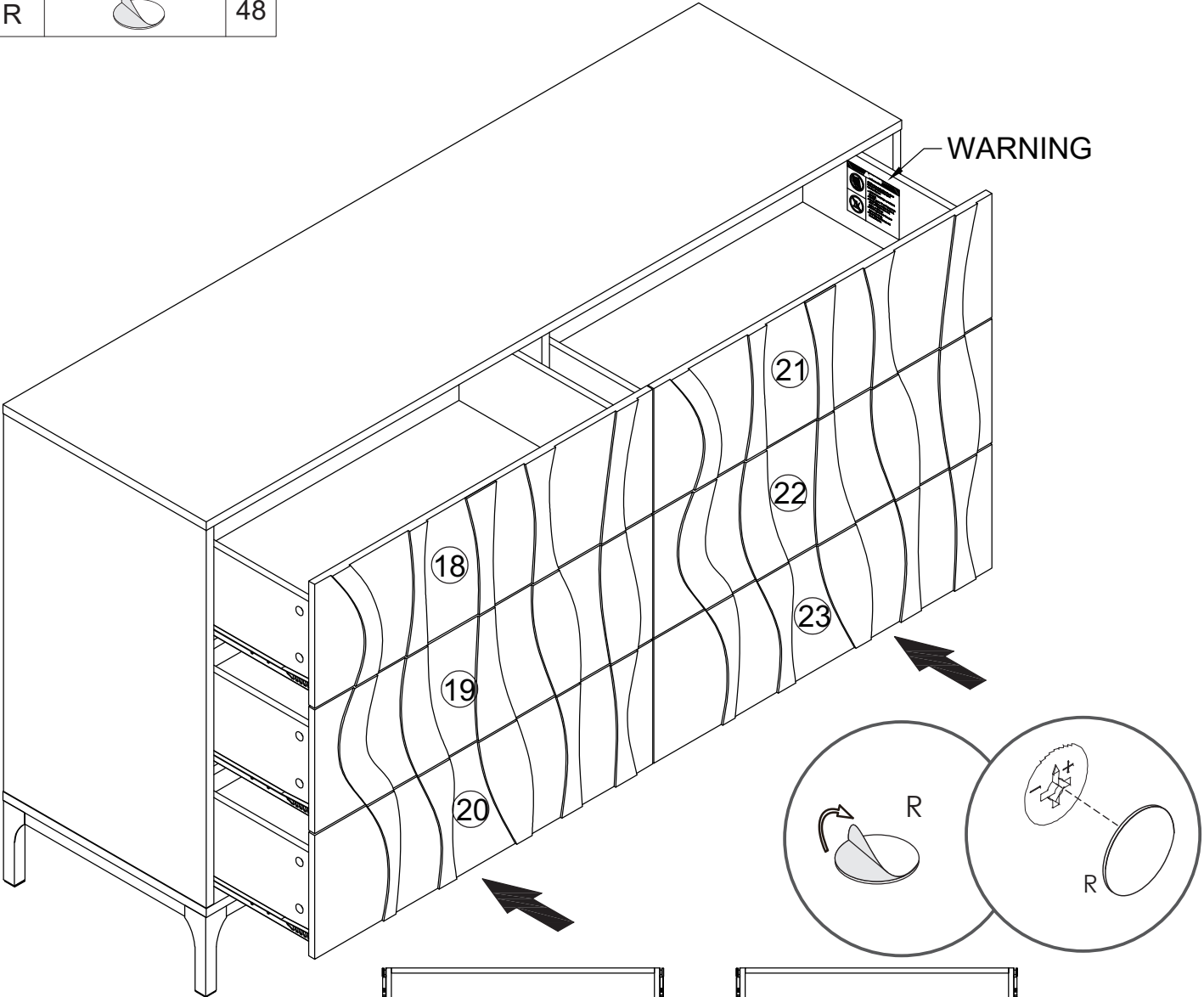

Please identify #13 #19 #20 and #21 #22 #23. Make sure 13 #19 #20 are for left drawer and #21 #22 #23 are for right drawer.

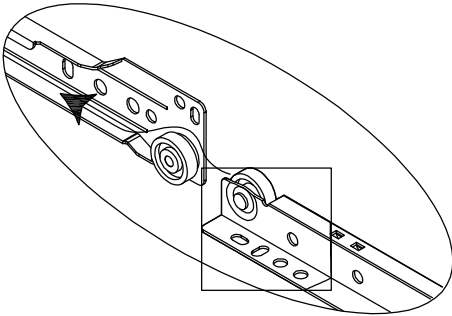
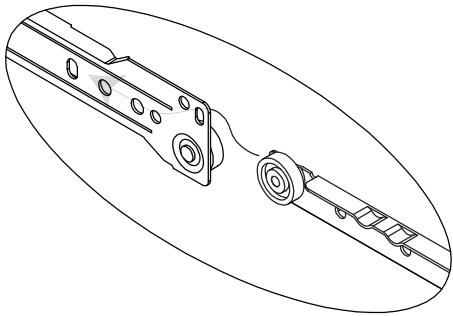

⚠ WARNING	
	<p>Children have died from furniture tipover. To reduce the risk of furniture tipover:</p> <ul style="list-style-type: none">- ALWAYS install Anti-tip device provided.- NEVER put a TV on this product.- NEVER allow children to stand, climb or hang on drawers, doors, or shelves.- NEVER open more than one drawer at a time.- Place heaviest items in the lowest drawers.
	<p style="text-align: center;">This is a permanent label. Do not remove!</p>

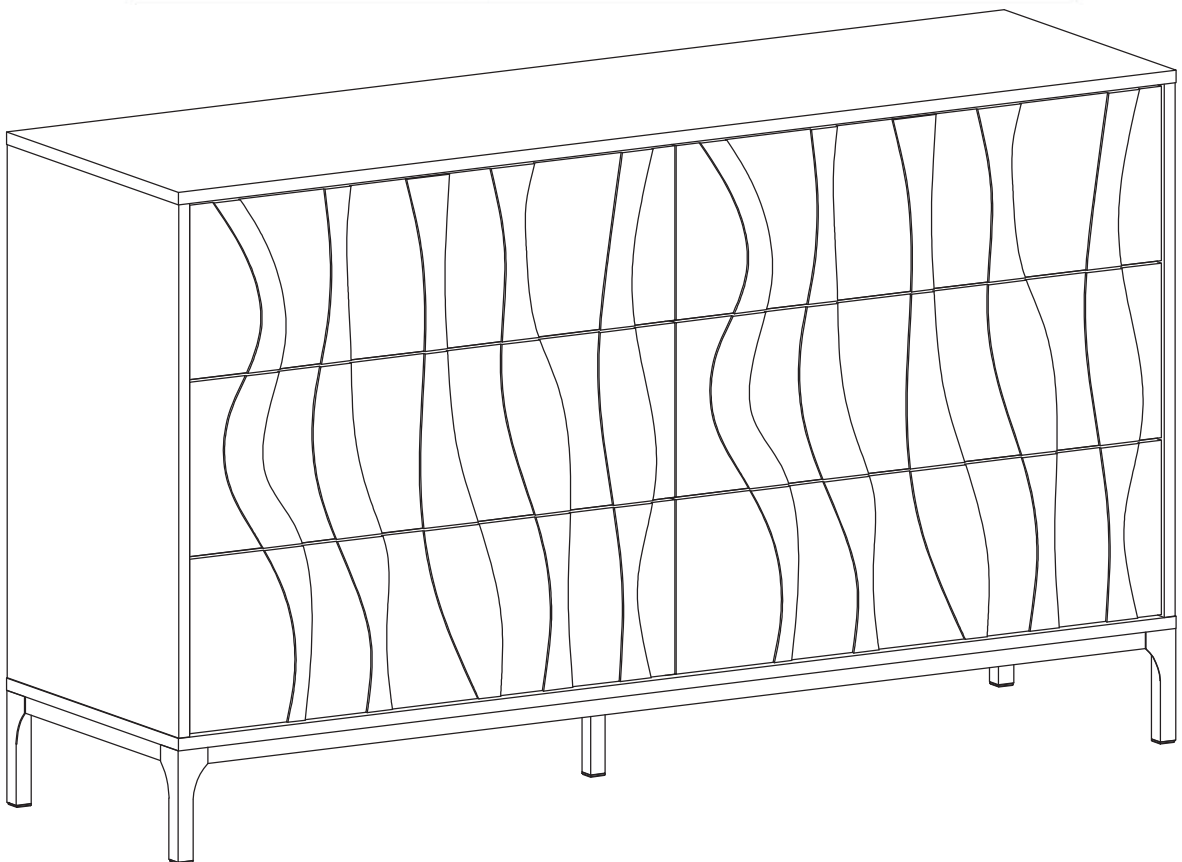

SAFETY FIRST, STYLE ALWAYS

Thank you for choosing our products. To ensure safety and performance, please follow these instructions:

- **Assembly:** Carefully follow instructions and tighten all parts.
- **Intended Use:** Use furniture as intended and adhere to weight limits.
- **Handling:** Move gently and check for loose parts regularly.
- **Tipping:** Tall or unstable furniture may tip over if not secured, especially in homes with children or pets.
- **Overloading:** Exceeding weight limits can lead to collapse or damage.
- **Sharp Edges:** Handle furniture with sharp corners carefully, especially around children.

MAINTENANCE & CLEANING TIPS

- **Regular Cleaning:** Use a soft, dry cloth to wipe the surface of the furniture regularly. Avoid harsh chemical cleaners.
- **Protect from Sunlight:** Keep the furniture out of direct sunlight to prevent damage to the material and finish.

DON'T WORRY, WE'VE GOT YOUR BACK.

We don't just sell furniture — we're here for the long haul! If you run into any issues due to manufacturing defects or material problems, we offer a 1-year warranty. That means we'll replace any faulty parts for free - no hassle.

Email: ServiceTeam86@outlook.com