

INSTRUCTION MANUAL

MANUEL D'INSTRUCTIONS MANUAL DE INSTRUCCIONES



UNDERMOUNT SINKS UNDERMOUNT SINKS UNDERMOUNT SINKS

HELPFUL TOOLS

For safety and ease of installation, the use of these helpful tools is recommended.

OUTILS UTILES

Pour des raisons de sécurité et de facilité d'installation, l'utilisation de ces outils utiles est recommandée.

HERRAMIENTAS ÚTILES

Por seguridad y facilidad de instalación, se recomienda el uso de estas útiles herramientas.

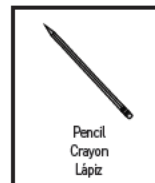

For warranty or additional information, contact:

US Customers

U.S.A.
houseofrohl.com/support
1-800-777-9762

QUEBEC / MARITIMES / WESTERN CANADA
QUÉBEC / MARITIMES / OUEST CANADIEN
QUEBEC / MARITIMOS / CANADA OCCIDENTAL
houseofrohl.ca/support
1-866-473-8442

Canadian Customers

ONTARIO
houseofrohl.ca/support
1-800-287-5354

4

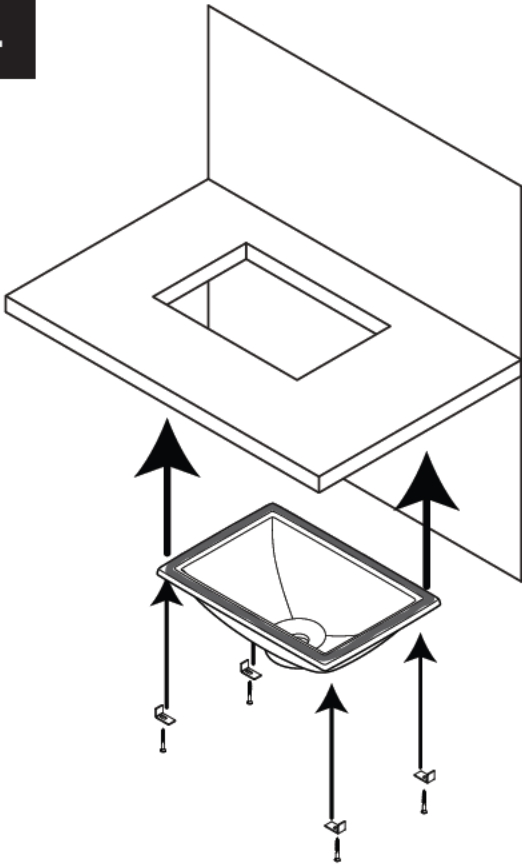

Bathroom Silicone (Not Supplied)
 Bathroom Silicone (Not Supplied)
 Bathroom Silicone (Not Supplied)

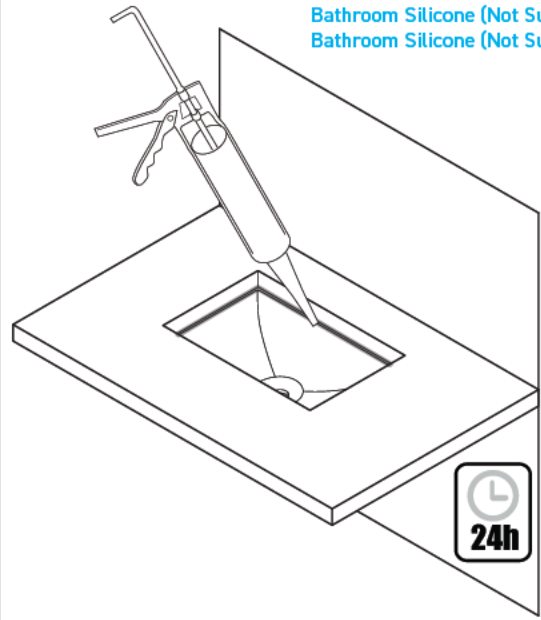

5

Wait 24 hours for the sealant to dry before use.
 Wait 24 hours for the sealant to dry before use.
 Wait 24 hours for the sealant to dry before use.

Timber Counter Installation
 Timber Counter Installation
 Timber Counter Installation

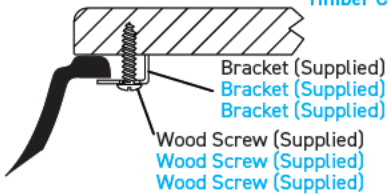

Bracket (Supplied)
 Bracket (Supplied)
 Bracket (Supplied)
 Wood Screw (Supplied)
 Wood Screw (Supplied)
 Wood Screw (Supplied)

Timber Counter Installation
 Timber Counter Installation
 Timber Counter Installation

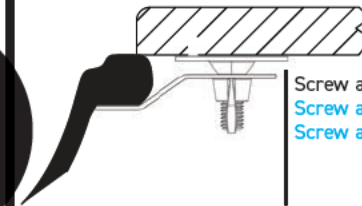

Screw and Wing Nut (Supplied)
 Screw and Wing Nut (Supplied)
 Screw and Wing Nut (Supplied)

OR

Stone/Marble etc. Installation
 Stone/Marble etc. Installation
 Stone/Marble etc. Installation

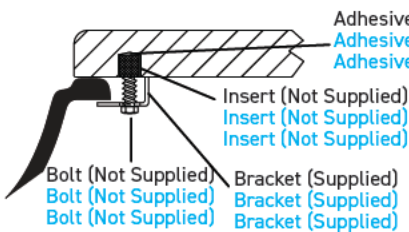

Adhesive (Not Supplied)
 Adhesive (Not Supplied)
 Adhesive (Not Supplied)
 Insert (Not Supplied)
 Insert (Not Supplied)
 Insert (Not Supplied)
 Bolt (Not Supplied)
 Bolt (Not Supplied)
 Bolt (Not Supplied)
 Bracket (Supplied)
 Bracket (Supplied)
 Bracket (Supplied)

Stone/Marble etc. Installation
 Stone/Marble etc. Installation
 Stone/Marble etc. Installation

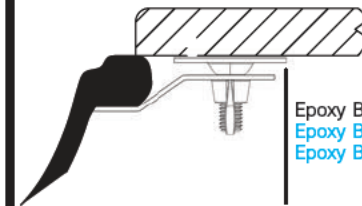

Epoxy Basin Adhesive (Not Supplied)
 Epoxy Basin Adhesive (Not Supplied)
 Epoxy Basin Adhesive (Not Supplied)

Once the sealant is applied, lift the sink up and press firmly on the underside to ensure there is a tight seal between the sink and counter. Based on the counter material, ensure you use the appropriate hardware as shown above to mount the sink in place.

Once the sealant is applied, lift the sink up and press firmly on the underside to ensure there is a tight seal between the sink and counter. Based on the counter material, ensure you use the appropriate hardware as shown above to mount the sink in place.

Once the sealant is applied, lift the sink up and press firmly on the underside to ensure there is a tight seal between the sink and counter. Based on the counter material, ensure you use the appropriate hardware as shown above to mount the sink in place.

