

# ASSEMBLY INSTRUCTIONS

## BRYCE DINING CHAIR

---

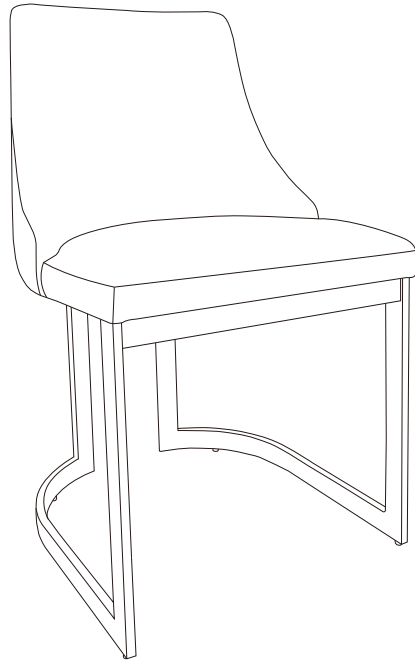

### Please read below before assembly:

- Assemble the product on a flat, soft surface such as a carpet or cloth to prevent scratching the finish.
- Do not discard any content until assembly is complete to avoid accidentally discarding small parts or hardware.
- Take out all parts and hardware from box.
- Failure to follow these instructions may cause the bolts to misalign during assembly.

### DISCLAIMERS:

- WHEN PROPERLY ASSEMBLED, THIS ITEM IS SAFE FOR INTENDED USE. SELLER IS NOT LIABLE FOR ANY DAMAGES RESULTING FROM ITEM BEING IMPROPERLY ASSEMBLED AFTER PURCHASE.
- BOLTS MAY LOOSEN DURING NORMAL EVERYDAY USE. THEY SHOULD BE INSPECTED AT LEAST EVERY 3 MONTHS AND RE-TIGHTEN AS NEEDED TO PREVENT DAMAGE OR INJURY, AND ENSURE STABILITY.

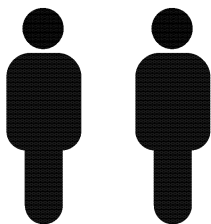

PEOPLE NEEDED

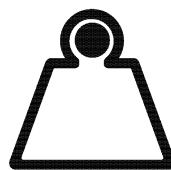





300  
lbs seat  
WEIGHT LIMIT





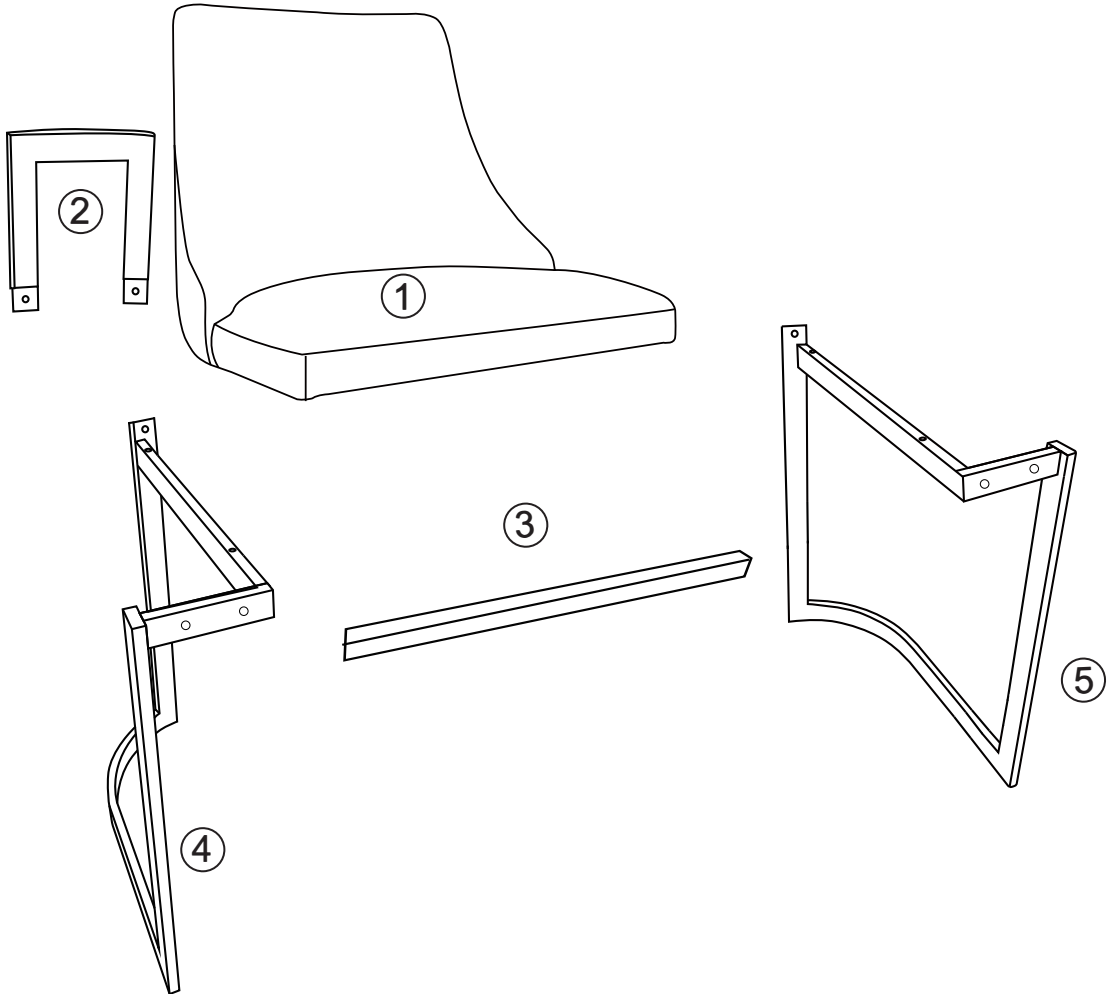

ESTIMATED TIME

# PARTS LIST

①	CHAIR TOP		1PC
②	BACK METAL FRAME		1PC
③	TOP STRETCHER		1PC
④	LEFT METAL FRAME		1PC
⑤	RIGHT METAL FRAME		1PC



# HARDWARE LIST



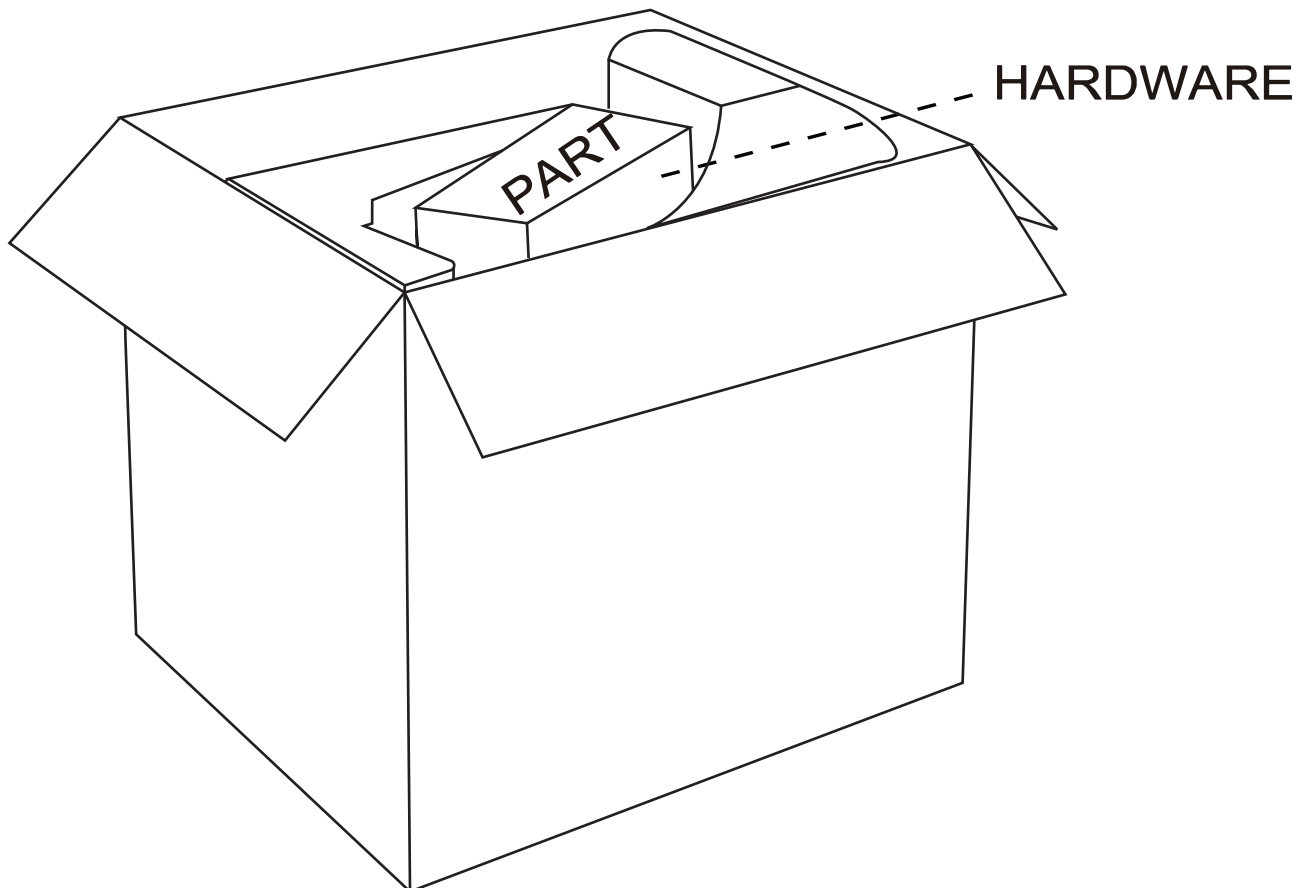

A	SHORT BOLT: Ø 1/4" x 5/8"		6 PCS
B	LONG BOLT: Ø 1/4" x 2-3/8"		4 PCS
C	LOCK WASHER: Ø 1/4"		2 PCS
D	FLAT WASHER: Ø 1/4"		2 PCS
E	ALLEN KEY		1 PC

## STEP 1

LOCATE PARTS AND HARDWARE PER BELOW DRAWING



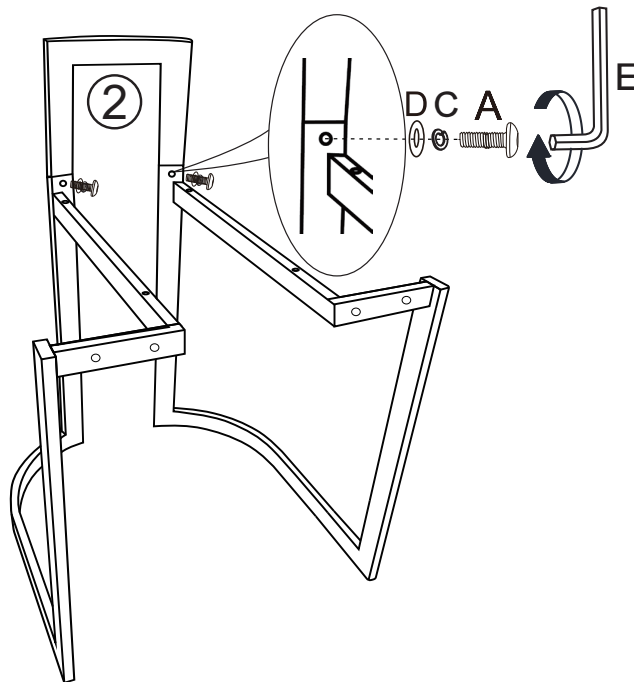
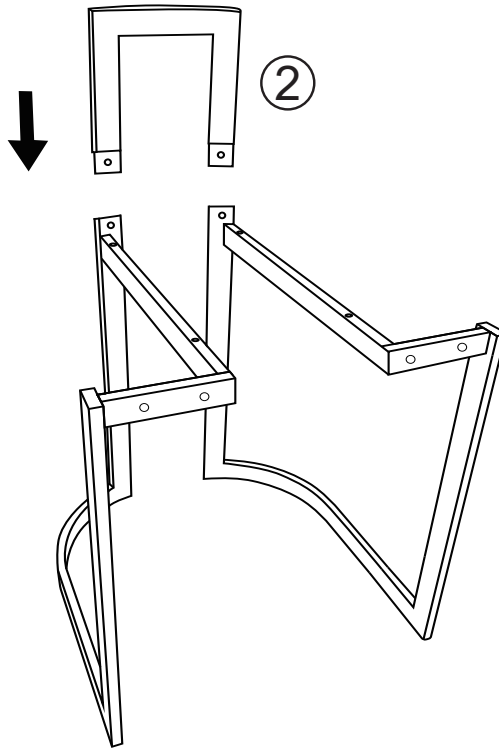

# STEP 2

A		2 PCS
C		2 PCS
D		2 PCS
E		1 PC



**PLEASE DO NOT FULLY TIGHTEN BOLTS**

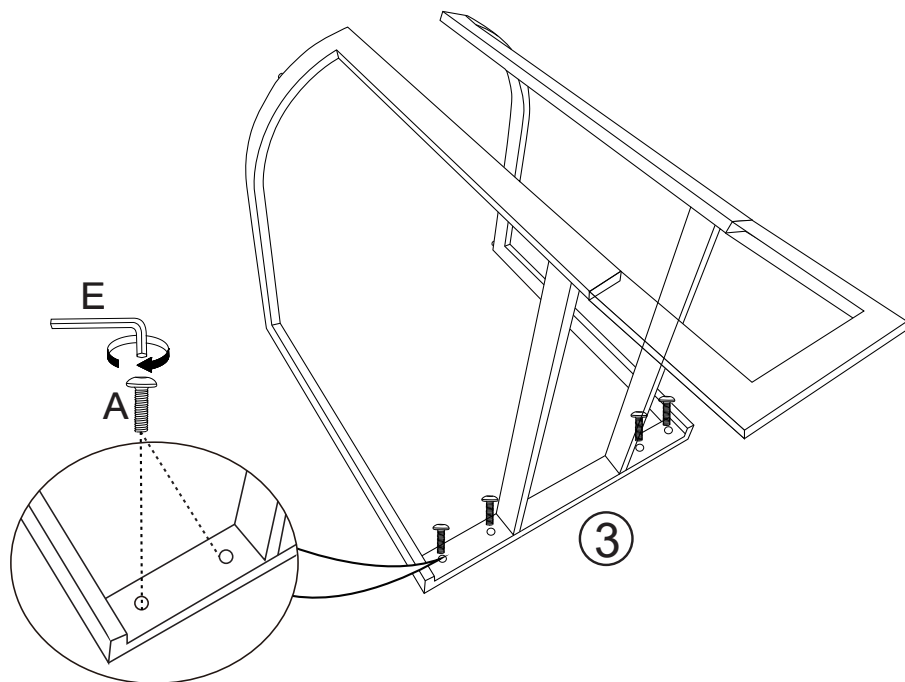
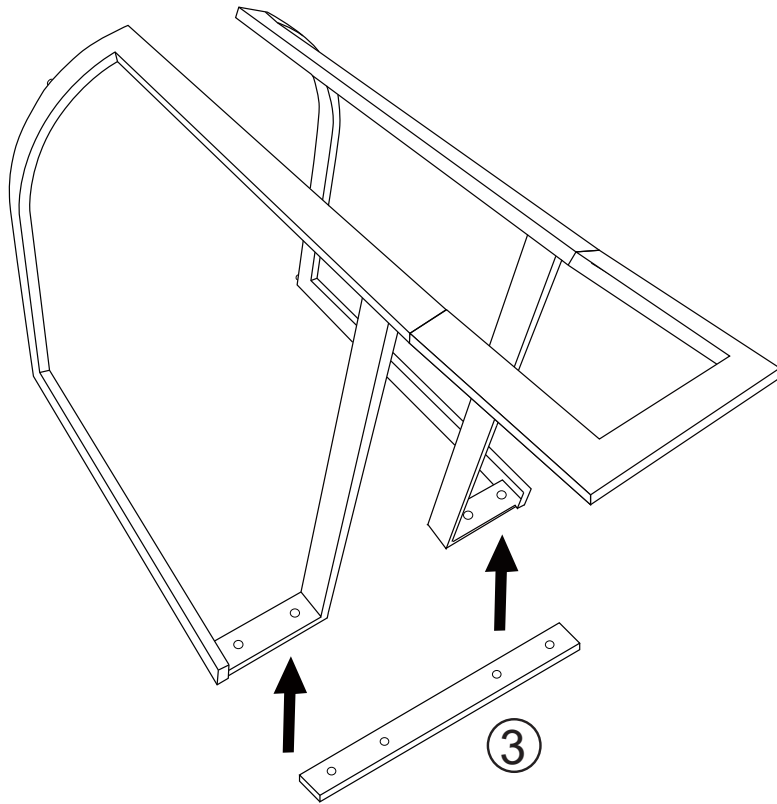

# STEP 3

A		4 PCS
E		1 PC



**PLEASE TIGHTEN ALL BOLTS**

# STEP 4

B		4 PCS
E		1 PC

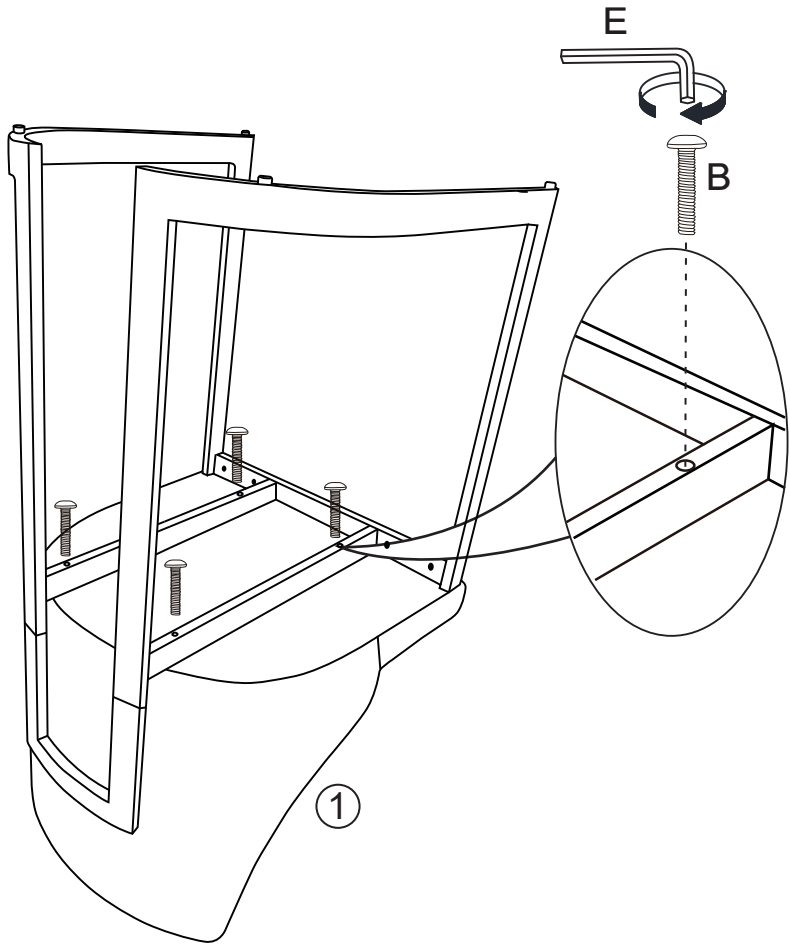

**PLEASE TIGHTEN ALL BOLTS**

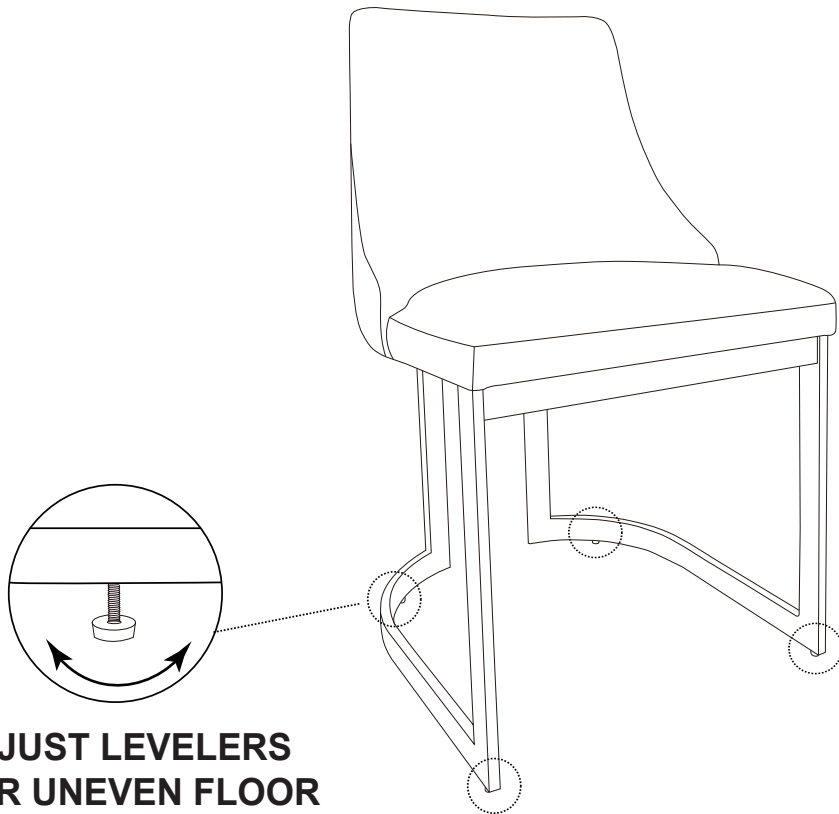

**ADJUST LEVELERS  
FOR UNEVEN FLOOR**

# Care & Maintenance

---

## Do...



Wipe up spills immediately.



Dust and pick-up spills using a clean, non-colored, lint-free, dry cloth.



Use mild non-abrasive soap and water.

---

## Don't...



Do not put hot items directly on furniture surface.



Do not clean furniture with harsh cleansers or polish.

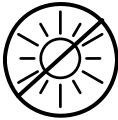

Do not place furniture in direct sunlight.



Do not place furniture near heating or cooling vents.



Do not write on furniture without a padded barrier to protect the surface.



Do not place furniture outside. For indoor use only.