

Installation & Assembly

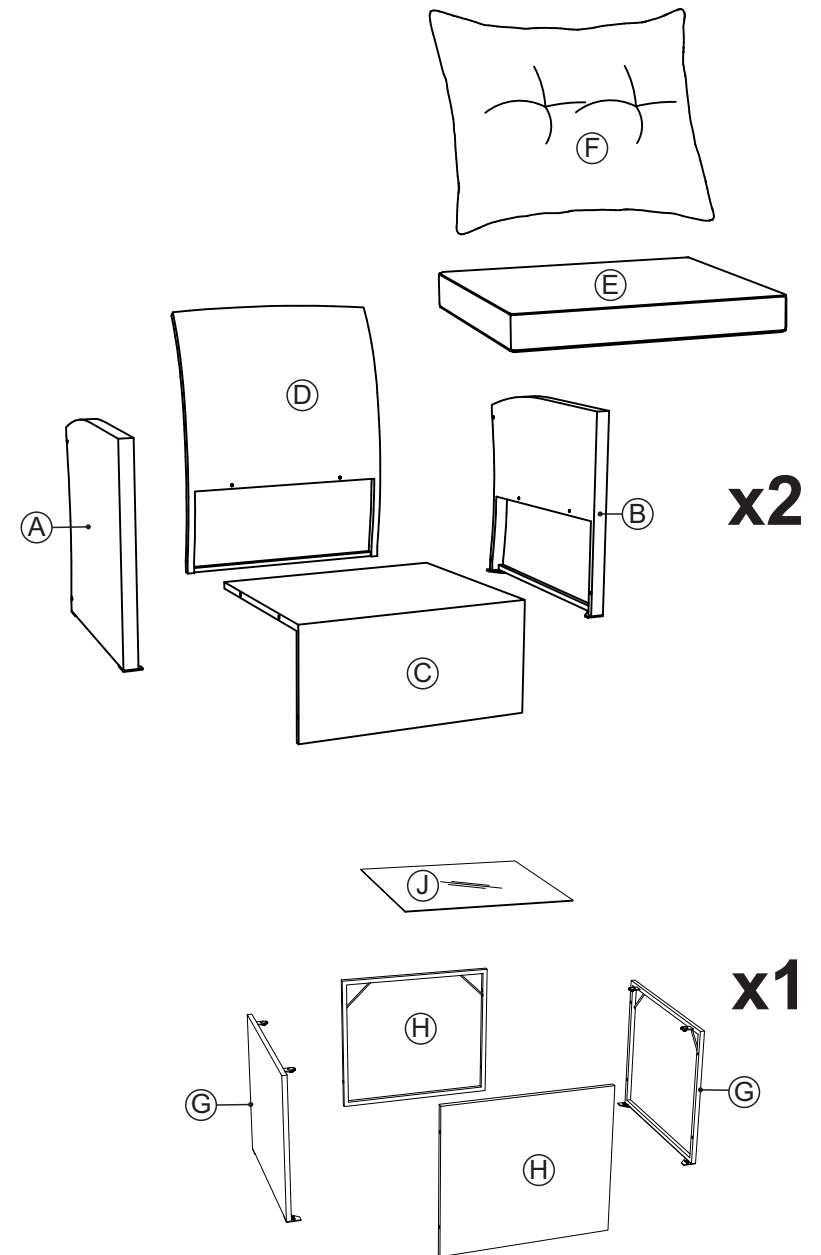

Before You Start

- ⚠ Please read all instructions carefully.
- ⚠ Retain instructions for future reference.
- ⚠ Separate and count all parts and hardware.
- ⚠ Read through each step carefully and follow the proper order.
- ⚠ We recommend that, where possible, all items are assembled near to the area in which they will be placed in use, to avoid moving the product unnecessarily once assembled.
- ⚠ Always place the product on a flat, steady and stable surface.
- ⚠ Keep all small parts and packaging materials for this product away from babies and children as they potentially pose a serious choking hazard.



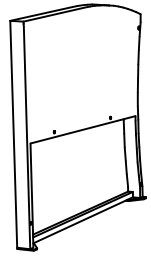

Ⓐ ×2

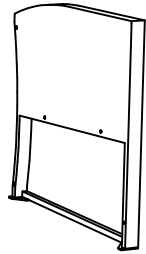

Ⓑ ×2

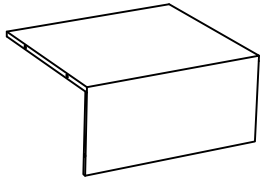

Ⓒ ×2

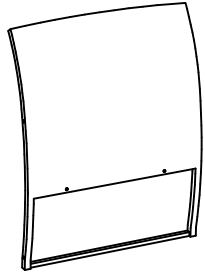

Ⓓ ×2

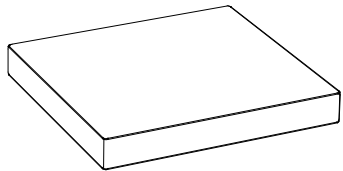

Ⓔ ×2

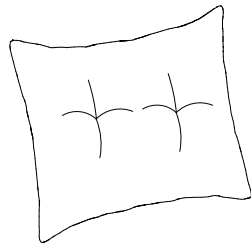

Ⓕ ×2

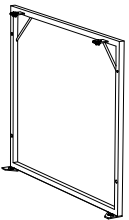

Ⓖ ×2

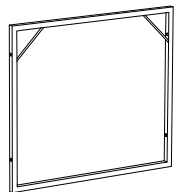

Ⓗ ×2



410x410x5 mm

Ⓙ ×1



M6x25 mm

①

x8



M6x35 mm

②

x16

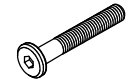

M6x55 mm

③

x20



∅6x14x1mm

④

x32



40x40x66 mm

⑤

x12



4x98 mm

⑥

x2

Allen Key

1

x2

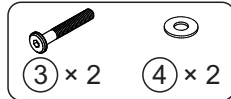
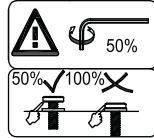
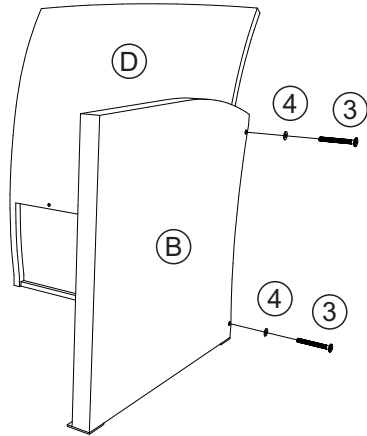

2

x2

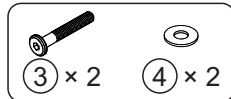
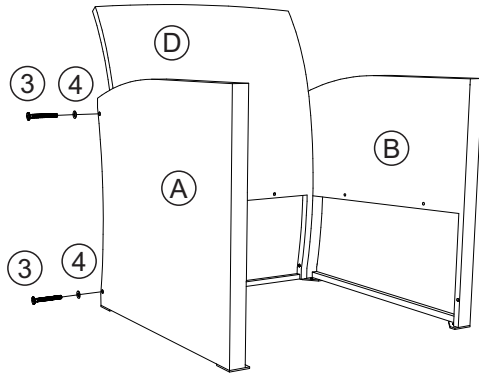

3

x2

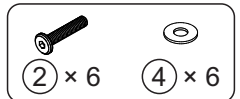
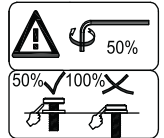
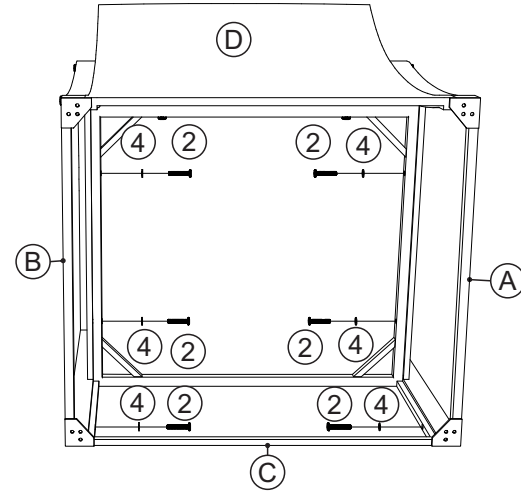

4

x2

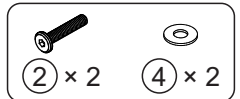
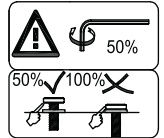
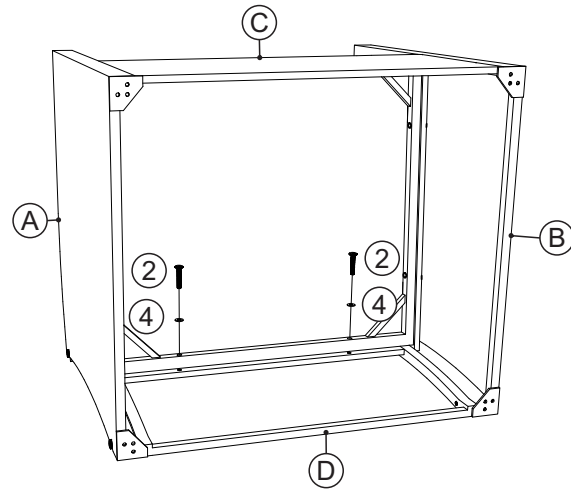

5

x2

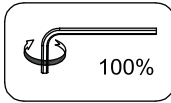
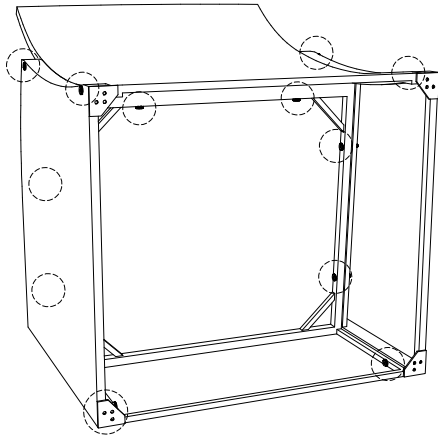

6

x2

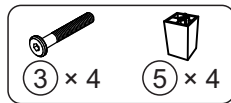
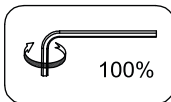
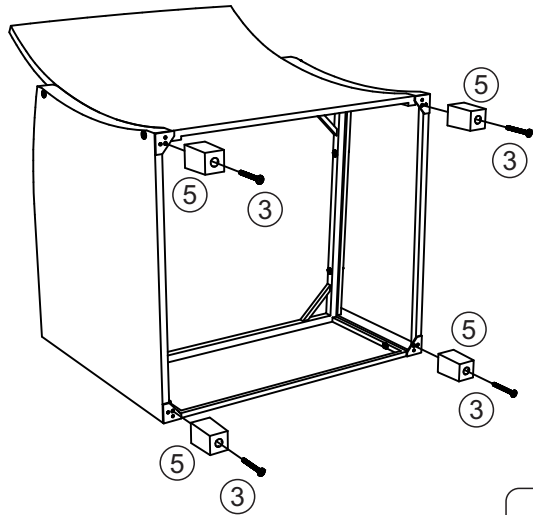

7

x2

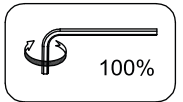
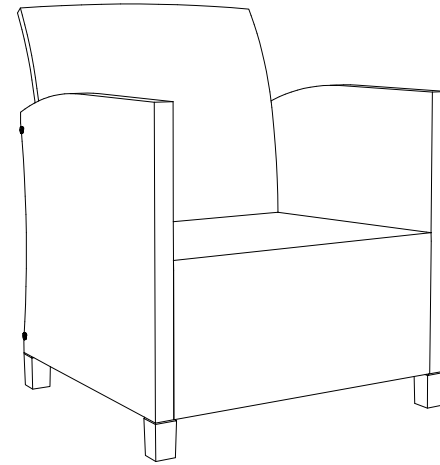

8

x2

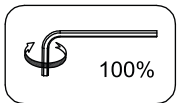
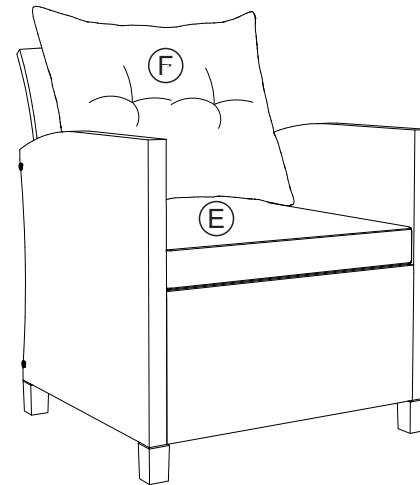

9

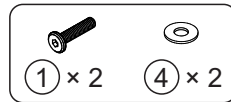
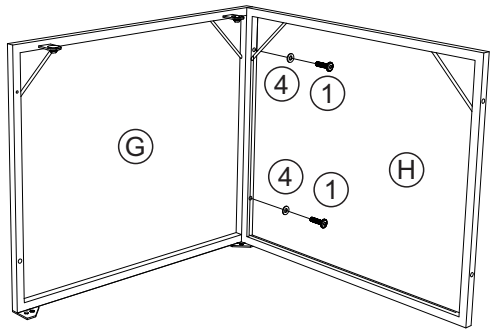

11

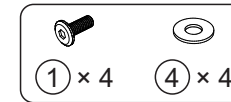
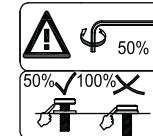
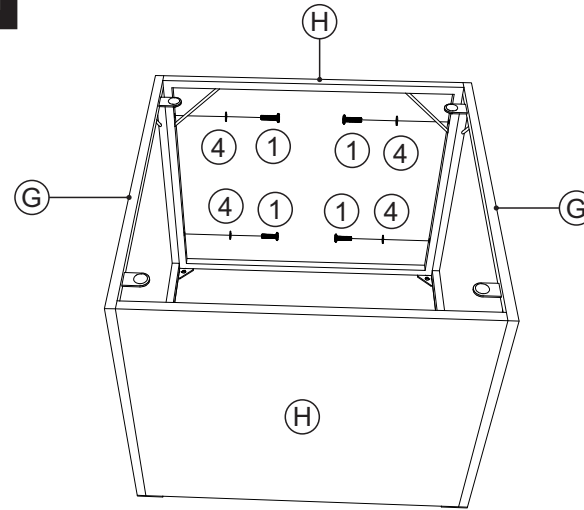

10

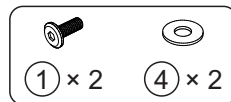
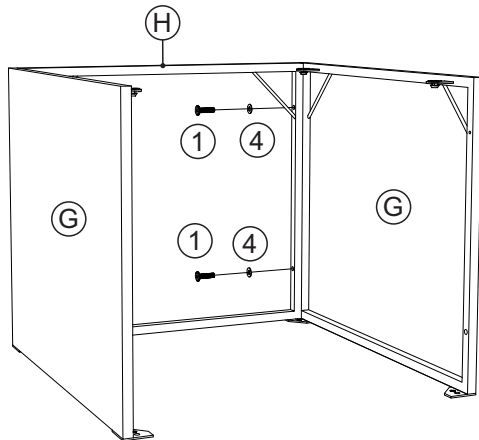

12

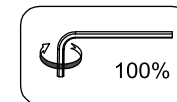
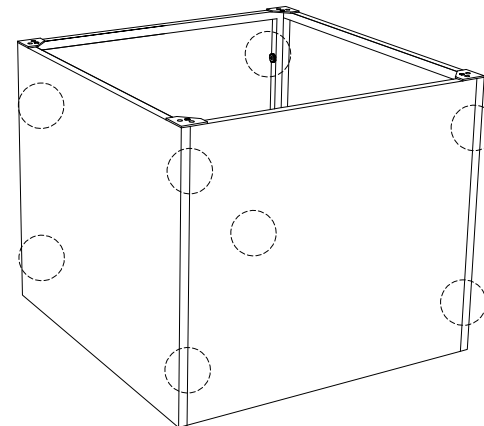

13

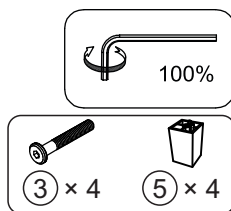
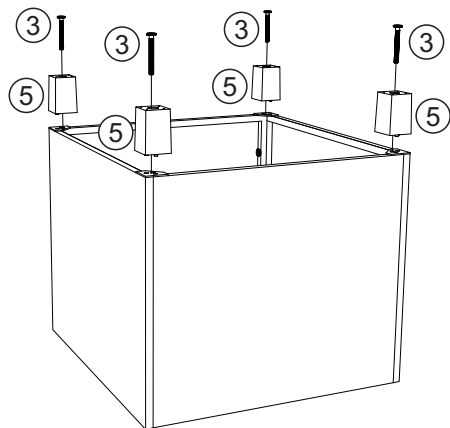

14

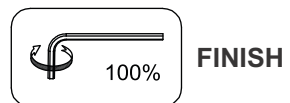
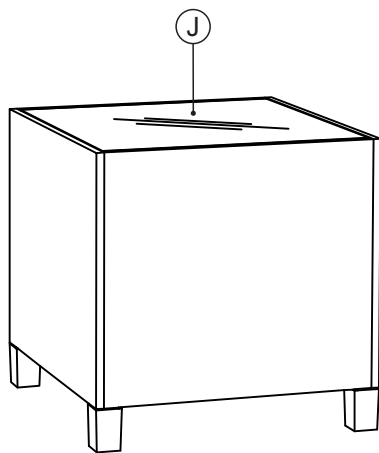

15

