





ASSEMBLY INSTRUCTIONS

DINING CHAIR

IMPORTANT NOTE:

- * PLACE ALL WOODEN PARTS ON A CLEAN AND SMOOTH SURFACE SUCH AS A RUG OR CARPET TO AVOID THE PARTS FROM BEING SCRATCHED.
- * BEFORE YOU BEGIN, KINDLY FOLLOW THE ASSEMBLY INSTRUCTIONS STEP BY STEP.
- * DO NOT TIGHTEN ALL SCREWS UNTIL THE CHAIR IS FULLY SET-UP.
- ** AFTER A FEW DAYS OF INITIAL ASSEMBLY AND CHAIR HAVE ACCLIMATED TO NEW ENVIRONMENT, RETIGHTEN ALL HARDWARE.

HARDWARE LIST

NO	DESCRIPTION	QTY
A	JCBC BOLT 	6PCS
B	SPRING WASHER 	5PCS
C	WOOD SCREW 	3PCS
D	ALLEN KEY 	1 PC
E	FLAT WASHER 	6PCS

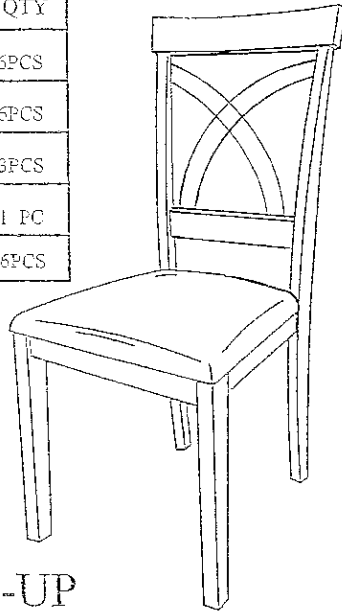

FULLY SET-UP

STEP 1

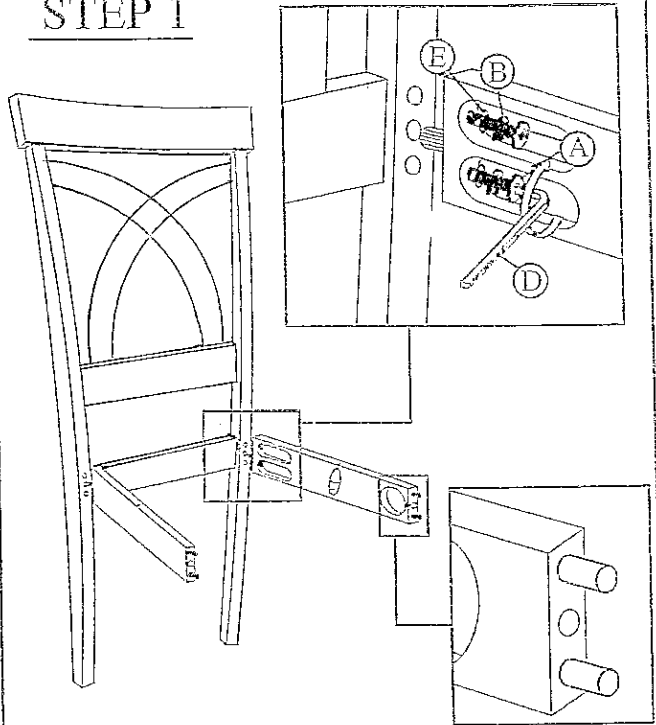

STEP 2

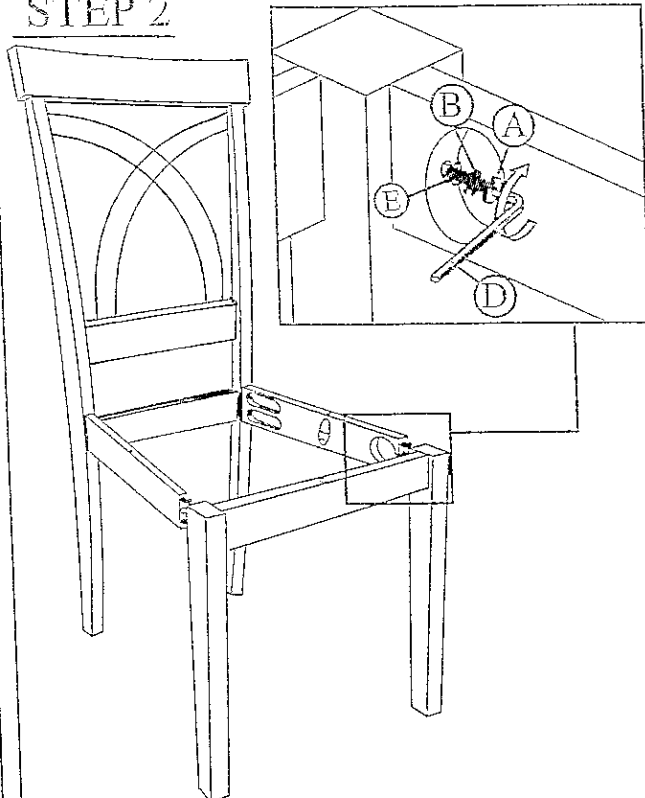

STEP 3

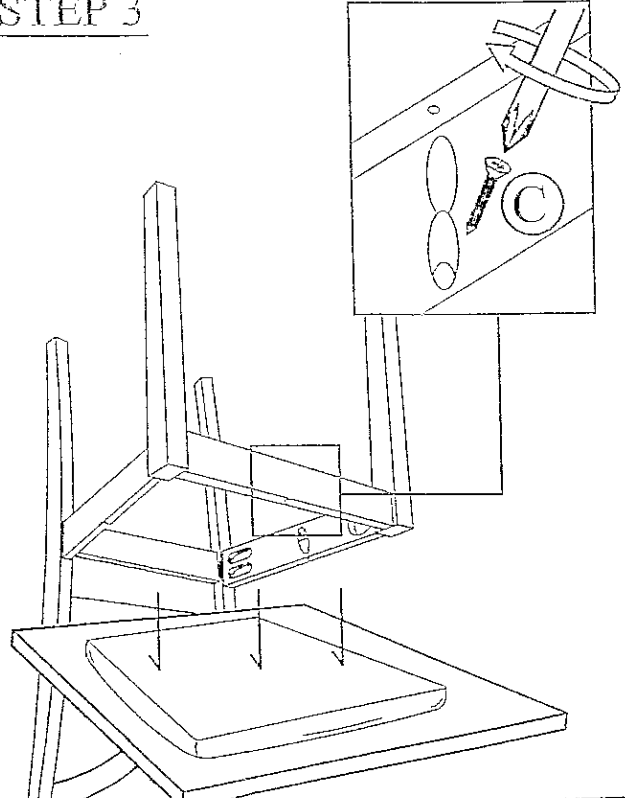





ASSEMBLY INSTRUCTION

DINING TABLE

IMPORTANT NOTE :

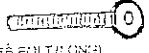
BEFORE YOUR BEGIN, PLEASE READ AND FOLLOW THE ASSEMBLY INSTRUCTIONS CAREFULLY.

- IDENTIFY AND SEPARATE ALL PARTS BEFORE DISCARDING PACKING.
- PLACE WOODEN PARTS ON A CLEAN SOFT SURFACE TO AVOID SCRATCHING THE PARTS.
- **DO NOT USE POWER TOOL FOR ASSEMBLY.**
- AS WITH ALL FURNITURE, OCCASIONALLY CHECK TO INSURE HARDWARE IS TIGHT.

PART LIST		
A	TABLE TOP	1 PC
B	TABLE LEGS	4 PCS
HARDWARE LIST		
C	 HEX SCREW (LONG)	8 PCS
D	 FLAT WASHER	8 PCS
E	 ALLEN KEY	1 PC
F	 SPRING WASHER	8 PCS

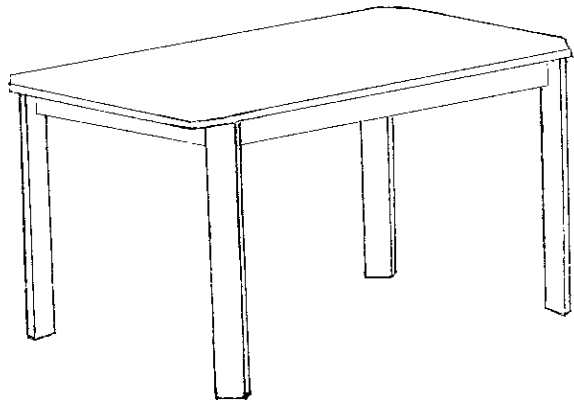

ATTACH THE TABLE LEGS (B) TO THE CORNER BLOCK WITH HEX SCREW (C) SPRING WASHER (F) AND FLAT WASHER (D). TIGHTEN THE HEX SCREW (C) BY USING THE HEX WRENCH (E).

