

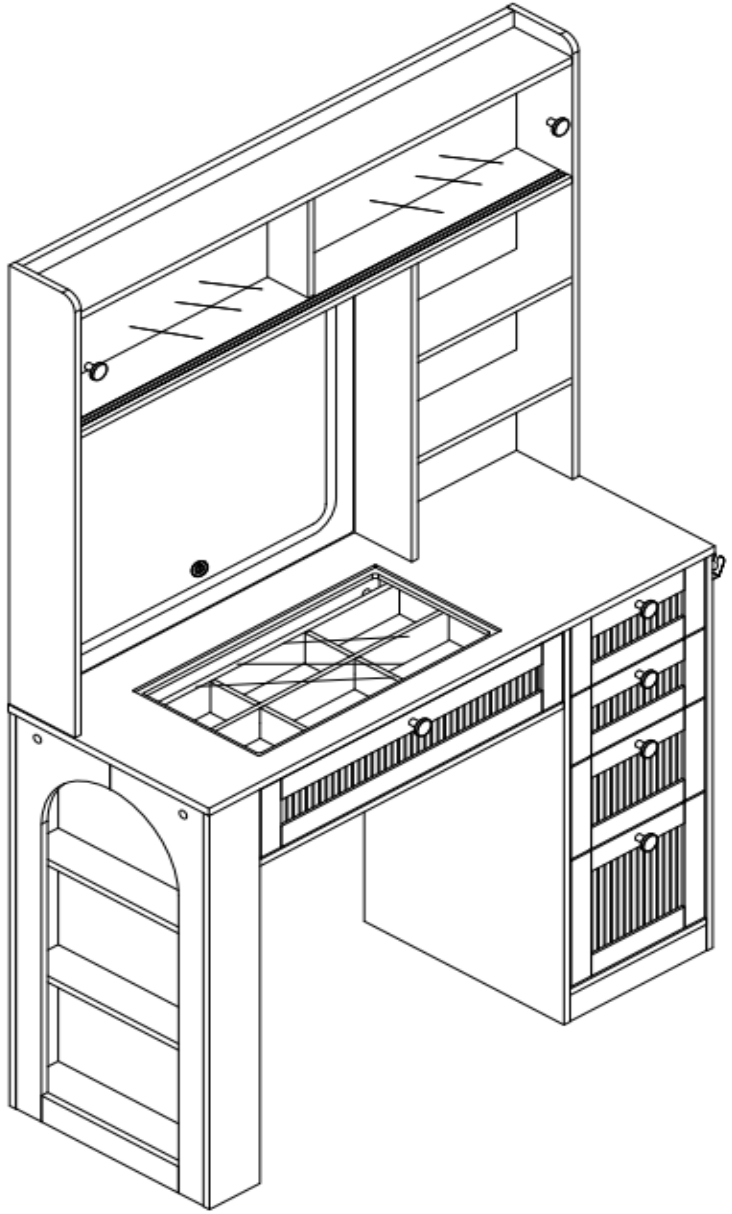

# INSTRUCTION

Product Name

IRONCK



Please don't tighten the screws completely and go back later for a final tightening of all the screws after pieces are aligned with each other

# EN

## 1. PRECAUTIONS

- When moving furniture, do not drag, always lift.
- Check all fixings regularly to ensure that they are not loose and retighten if necessary.
- Handle or move furniture with care, as carelessness may cause damage or injury.
- Furniture can be dangerous if not installed correctly.

No liability will be assumed for damage or injury caused by improper installation or assembly.  
Keep these instructions for future reference

## 2. CARE AND MAINTENANCE

- Dust regularly with a clean, soft, dry cloth.
- Do not use any abrasive or acidic products.
- Never use cleaningsolvents.
- For professional cleaning only.

## 3. WARNING

- Use the provided wall mount.
- Never allow children to climb or hang on drawers, doors or shelves.
- Place the heaviest items in the drawers or shelves below.
- Do not place a television or other heavy objects on top of this product unless it is specifically designed to accommodate.
- Do not open more than one drawer at a time.

Accessory devices come with your product; however, you need to find the right fixtures for your wall type. If in doubt, consult a qualified professional.

Always make sure that the wall you are drilling into is free of hidden electrical wires, water pipes, and gas pipes.

## 4. ISTRUZIONI PER L'INSTALLAZIONE

- Il montaggio deve essere eseguito solo da un adulto competente.
- I bambini devono essere tenuti lontani dal prodotto durante l'assemblaggio, poiché potrebbe esserci il rischio di lesioni.
- Non utilizzare il prodotto se alcune parti sono mancanti o danneggiate.

# DE

## 1. HINWEISE

- Ziehen Sie beim Bewegen von Möbeln nicht daran, sondern heben Sie sie immer an.
- Überprüfen Sie regelmäßig alle Befestigungen auf Lockerheit und ziehen Sie diese gegebenenfalls nach.
- Seien Sie beim Umgang mit oder beim Bewegen von Möbeln vorsichtig, da Unachtsamkeit zu Schäden oder Verletzungen führen kann.
- Möbel können gefährlich sein, wenn sie nicht richtig installiert werden.

Für Schäden oder Verletzungen, die durch unsachgemäße Installation oder Montage entstehen, wird keine Haftung übernommen.

Bewahren Sie diese Anweisungen zum späteren Nachschlagen auf.

## 2. PFLEGE UND WARTUNG

- Stauben Sie regelmäßig mit einem sauberen, weichen und trockenen Tuch ab.
- Verwenden Sie keine Scheuermittel oder säurehaltigen Produkte.
- Verwenden Sie keine Reinigungslösungsmittel.
- Nur für die professionelle Reinigung.

## 3. WARNUNG

- Verwenden Sie die mitgelieferte Wandhalterung.
- Erlauben Sie Kindern niemals, auf Schubladen, Türen oder Regale zu klettern oder sich daran festzuhalten.
- Platzieren Sie die schwersten Gegenstände in unteren Schubladen oder auf Regalen.
- Stellen Sie keinen Fernseher oder schwere Gegenstände auf die Oberseite dieses Produkts, es sei denn, es ist speziell dafür konzipiert, solche Lasten aufzunehmen.
- Öffnen Sie nicht mehr als eine Schublade gleichzeitig.

Die Befestigungsvorrichtung ist im Lieferumfang Ihres Produkts enthalten. Sie müssen jedoch die passende Halterung für Ihren Wandtyp finden. Im Zweifelsfall wenden Sie sich an einen qualifizierten Fachmann.

Stellen Sie immer sicher, dass in der Wand, in die Sie bohren, keine versteckten Strom-, Wasser- und Gasleitungen vorhanden sind.

## 4. INSTALLATIONSANLEITUNG

- Die Montage darf nur von fachkundigen Erwachsenen durchgeführt werden.
- Kinder sollten während der Montage vom Produkt ferngehalten werden, da Verletzungsgefahr besteht.
- Verwenden Sie diesen Artikel nicht, wenn Teile fehlen oder beschädigt sind.

# FR

## 1. PRÉCAUTIONS

- Lorsque vous déplacez des meubles, ne les traînez pas, soulevez-les toujours.
- Vérifiez régulièrement toutes les fixations pour vous assurer qu'elles ne se sont pas desserrées et resserrez-les si nécessaire.
- Soyez prudent lorsque vous manipulez ou déplacez des meubles, car une négligence peut entraîner des dommages ou des blessures.
- Les meubles peuvent être dangereux s'ils ne sont pas installés correctement.

Aucune responsabilité ne sera assumée pour les dommages ou blessures résultant d'une installation ou d'un assemblage incorrect.

Conservez ces instructions pour référence ultérieure

## 2. ENTRETIEN ET MAINTENANCE

- Dépoussiérez régulièrement avec un chiffon propre, doux et sec.
- N'utilisez pas de produits abrasifs ou acides.
- N'utilisez pas de solvants de nettoyage.
- Pour nettoyage professionnel uniquement

## 3. VERTISSEMENT

- Utilisez le support mural fourni.
- Ne laissez jamais les enfants grimper ou s'accrocher aux tiroirs, aux portes ou aux étagères.
- Placez les articles les plus lourds dans les tiroirs inférieurs ou sur des étagères.
- Ne placez pas de téléviseur ou d'autres objets lourds sur ce produit, à moins qu'ils ne soient spécifiquement conçus pour les accueillir.
- N'ouvrez pas plus d'un tiroir à la fois.

L'équipement de fixation est fourni avec votre produit ; Cependant, vous devrez trouver le luminaire approprié à votre type de mur. En cas de doute, consultez un professionnel qualifié. Assurez-vous toujours que le mur dans lequel vous percez est exempt de fils électriques, de conduites d'eau et de conduites de gaz cachés

## 4. GUIDE D'INSTALLATION

- L'assemblage doit être effectué uniquement par des adultes compétents.
- Les enfants doivent être tenus à l'écart du produit pendant le montage car il existe un risque de blessure.
- N'utilisez pas cet article si des pièces sont manquantes ou endommagées.

## 1. PRECAUZIONI

- Non trascinare i mobili durante lo spostamento, ma sollevarli sempre.
- Controllare regolarmente tutti i fissaggi per verificare che non vi siano allentamenti e serrare nuovamente se necessario.
- Maneggiare o spostare i mobili con cautela, poiché la disattenzione può causare danni o lesioni.
- I mobili possono essere pericolosi se non installati correttamente.

Non ci si assume alcuna responsabilità per danni o lesioni causati da un'installazione o un montaggio non corretti.

Conservare queste istruzioni per riferimenti futuri.

## 2. CURA E MANUTENZIONE

- Spolverare regolarmente con un panno pulito, morbido e asciutto.
- Non utilizzare prodotti abrasivi o acidi.
- Non utilizzare solventi per la pulizia. Solo pulizia professionale.

## 3. VATTENZIONE

- Utilizzare il dispositivo di montaggio a parete in dotazione.
- Non permettere mai ai bambini di arrampicarsi o appendersi ai cassetti, alle porte o ai ripiani.
- Collocare gli oggetti più pesanti nei cassetti o nei ripiani sottostanti.
- Non collocare televisori o altri oggetti pesanti sopra questo prodotto, a meno che non siano specificamente progettati per sostenerli.
- Non aprire più di un cassetto alla volta.

Gli accessori vengono forniti con il prodotto; tuttavia, è necessario trovare i dispositivi adeguati al tipo di parete. In caso di dubbi, consultare un professionista qualificato.

Assicurarsi sempre che la parete da forare sia priva di fili nascosti, tubi dell'acqua e del gas.

## 4. ISTRUZIONI PER L'INSTALLAZIONE

- Il montaggio deve essere eseguito solo da un adulto competente.
- I bambini devono essere tenuti lontani dal prodotto durante l'assemblaggio, poiché potrebbe esserci il rischio di lesioni.
- Non utilizzare il prodotto se alcune parti sono mancanti o danneggiate.

# ES

## 1. PRECAUCIONES

- No arrastre al mover los muebles, levántelos siempre.
- Compruebe regularmente todos los elementos de fijación para asegurarse de que no están flojos y vuelva a apretarlos si es necesario.
- Manipule o mueva los muebles con cuidado, ya que un descuido puede causar daños o lesiones.
- Los muebles pueden ser peligrosos si no se instalan correctamente.

No se aceptará ninguna responsabilidad por daños o lesiones causados por una instalación o montaje inadecuados.

Conserve estas instrucciones para futuras consultas.

## 2. CUIDADO Y MANTENIMIENTO

- Limpie regularmente el polvo con un paño limpio, suave y seco.
- No utilice productos abrasivos ni ácidos. No utilice disolventes de limpieza.
- Limpieza profesional únicamente.

## 3. ADVERTENCIA

- Utilice el dispositivo de fijación mural suministrado.
- Nunca permita que los niños trepen o se cuelguen de los cajones, puertas o estantes.
- Coloque los objetos más pesados en los cajones o estantes inferiores.
- No coloque televisores u otros objetos pesados encima de este producto a menos que estén específicamente diseñados para sostenerlos.
- No abra más de un cajón a la vez.

El equipo accesorio viene con su producto; sin embargo, usted necesitará encontrar los accesorios apropiados para su tipo de pared. En caso de duda, consulte a un profesional cualificado.

Asegúrese siempre de que la pared que va a perforar está libre de cables ocultos, tuberías de agua y tuberías de gas.

## 4. INSTRUCCIONES DE MONTAJE

- El montaje sólo debe ser realizado por un adulto competente.
- Los niños deben mantenerse alejados del producto durante el montaje, ya que puede haber riesgo de lesiones.
- No utilice este artículo si falta alguna pieza o está dañado.

## 1. 注意事項

- ・家具を移動するときは、ドラッグしないでください、常に持ち上げます。
- ・定期的にすべての固定具をチェックして、緩んでいないことを確認し、必要に応じて再固定します。
- ・不注意が損傷や怪我を引き起こす可能性があるため、家具を慎重に取り扱いまたは移動します。
- ・家具を正しく設置しないと危険になる可能性があります。

不適切な設置または組み立てによって引き起こされた損傷または怪我については、一切の責任を負いません。

これらの指示は、今後の参照のために保管してください。

## 2. ケアとメンテナンス

- ・きれいで柔らかく乾いた布で定期的にはこりをかけます。
- ・研磨剤や酸性製品を使用しないでください。洗剤溶剤を決して使用しない。
- ・プロのクリーニング用のみです。

## 3. 警告

- ・付属の壁掛け金具を使用してください。
- ・お子様が引き出し、扉、棚に登ったり、ぶら下がったりしないようにしてください。
- ・最も重いものは、下の引き出しまたは棚に置いてください。
- ・特別に設計されていない限り、テレビなどの重い物を本製品の上に置かないでください。
- ・一度にN数の引き出しを開けないでください。

製品には付属品が付属していますが、壁の種類に合った適切な器具を見つける必要があります。ご不明な点がある場合は、資格のある専門家にご相談ください。

穴を開ける壁には、電線、水道管、ガス管が隠れていないことを必ず確認してください。

・本製品には小さな部品が含まれています。すべての小さな部品は、お子様の手の届かないところに保管してください。これらの小さな部品を飲み込んだり、吸い込んだりすると、命に関わる可能性があります。

- ・窒息などの危険を避けるため、ビニール袋はお子様の手が届かないところに保管してください。

## 4. 設置ガイド

- ・組み立ては、必ず有資格の成人の方が行ってください。
- ・組み立て中は、怪我をする恐れがあるため、お子様が製品に近づかないようにしてください。
- ・部品が不足または破損している場合は、本製品を使用しないでください。

# NOTICE

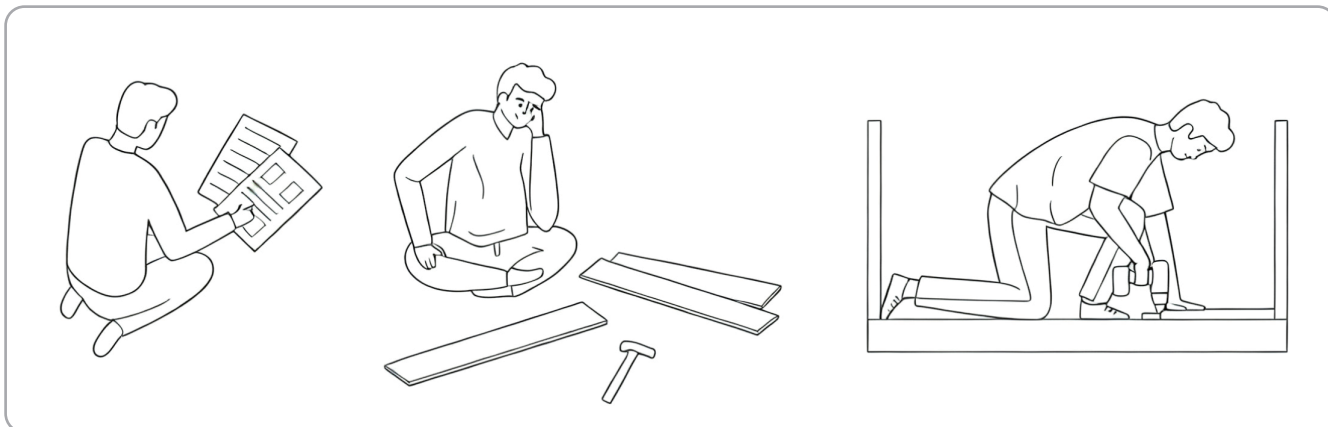

## EN:

- Important, retain for future reference: read carefully.
- Assemble on a flat, clean and soft surface.
- Professional installation is highly recommended.

## DE:

- Wichtig, für zukünftige Referenz aufbewahren: sorgfältig lesen.
- Montieren Sie auf einer ebenen, sauberen und weichen Oberfläche.
- Eine professionelle Installation wird stark empfohlen.

## FR:

- Important, conservez pour référence future : lisez attentivement.
- Assemblez sur une surface plate, propre et douce.
- Une installation professionnelle est fortement recommandée.

## IT:

- Importante, conservare per futura consultazione: leggere attentamente.
- Montare su una superficie piatta, pulita e morbida.
- Si consiglia vivamente un'installazione professionale.

## ES:

- Important, retain for future reference: read carefully
- Montar en una superficie plana, limpia y suave.
- Se recomienda encarecidamente la instalación profesional.

## JP:

- ・重要、今後の参考のために保管してください：よくお読みください。
- ・平らで清潔で柔らかい表面の上で組み立ててください。
- ・専門家による設置を強くお勧めします。

# NOTICE

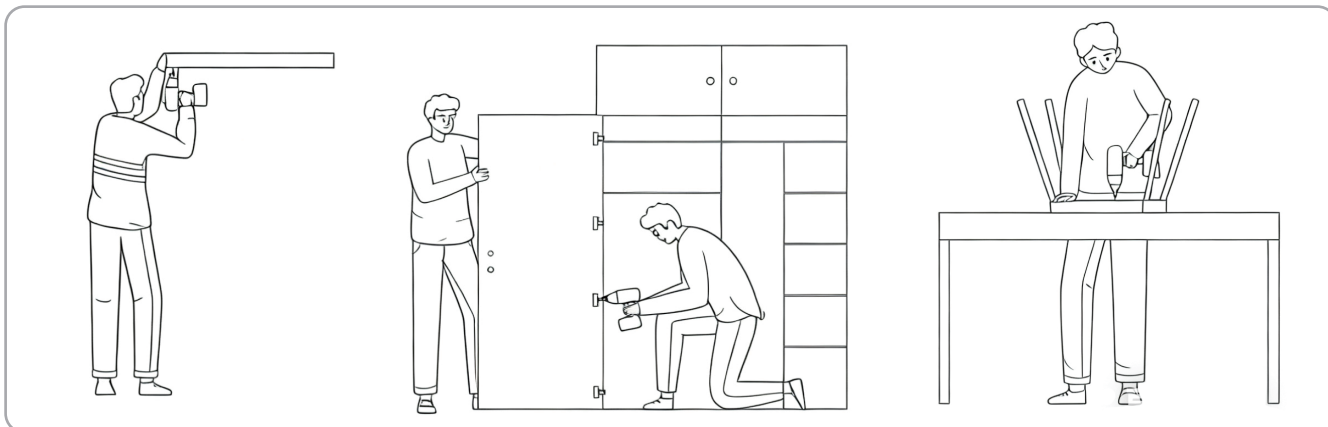

## EN:

- Periodically Check That All Components Are Tightly Secured.
- It is recommended that multiple people assemble this product.
- Using cam lock and QuickFit.

## DE:

- Überprüfen Sie regelmäßig, ob alle Komponenten fest und sicher befestigt sind.
- Es wird empfohlen, dass mehrere Personen dieses Produkt zusammenbauen.
- Verwendung von Kippverschluss und Schnellverschluss.

## FR:

- Vérifiez périodiquement que tous les composants sont bien fixés.
- Il est recommandé que plusieurs personnes assemblent ce produit.
- Utilisation de verrou de came et d'adaptateur rapide.

## IT:

- Controllare periodicamente che tutti i componenti siano saldamente fissati.
- Si consiglia che più persone assemblino questo prodotto.
- Utilizzando la chiusura a cam e il Quickfit.

## ES:

- Periodicamente verifique que todos los componentes estén firmemente asegurados.
- Se recomienda que varias personas ensamblen este producto.
- Usando bloqueo de came y conexión rápida.

## JP:

- すべてのコンポーネントがしっかりと固定されているかどうかを定期的に確認してください。
- この製品は複数人で組み立てることをお勧めします。
- カムロックとクイックフィットの使用。

# NOTICE

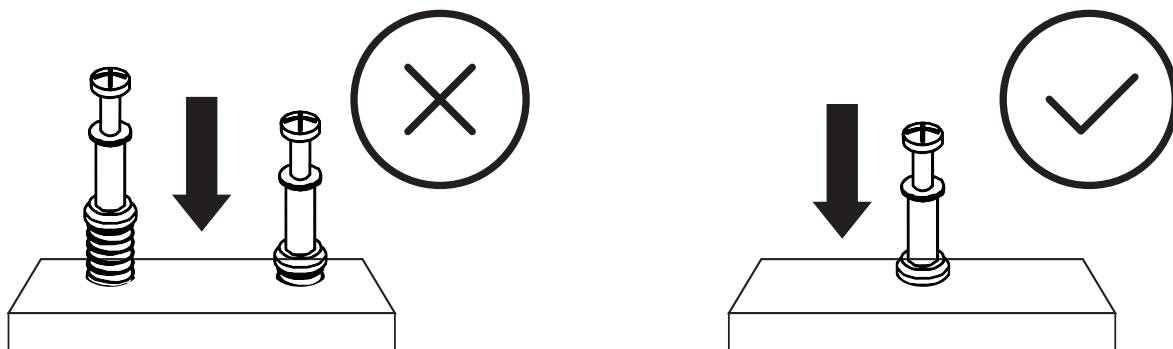

EN: Tighten QuickFit until the shoulder is flush with the panel. Do not overtighten or undertighten.

DE: Ziehen Sie das QuickFit an, bis der Schulterbereich mit der Platte in Ebene liegt. Über- oder Unteranziehen ist nicht erlaubt.

FR: Serrer le QuickFit jusqu'à ce que l'épaule soit parfaitement alignée avec le panneau. Ne pas sur-tendre ni sous-tendre.

IT: Allacciare il QuickFit fino a quando la spalla è a filo con il pannello. Non allacciare troppo o troppo poco.

ES: Apretar QuickFit hasta que el hombro quede al ras con el panel. No apretar demasiado ni demasiado poco.

JP: クイックフィットを、ショルダー部分がパネルと面一になるまで締め付けてください。締めすぎたり、締め不足になったりしないでください。

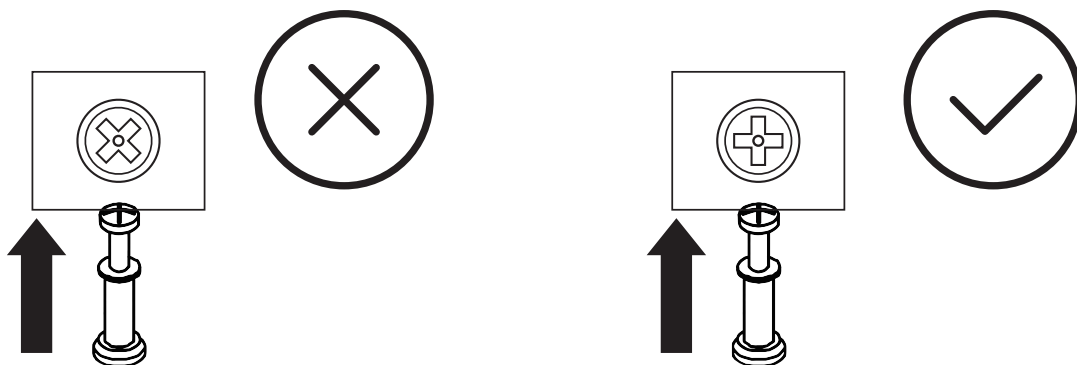

EN: When fitting the cam lock, ensure the starting position is correct before inserting the connecting QuickFit.

DE: Beim Einbau des Kippverschlusses stellen Sie sicher, dass die Ausgangsposition korrekt ist, bevor Sie das Schnellkupplungsstück einstecken.

FR: Lors du montage du verrou à came, assurez-vous que la position de départ est correcte avant d'insérer le raccord rapide.

IT: Quando si avvita il blocco a camma, assicurarsi che la posizione di partenza sia corretta prima di inserire il collegamento QuickFit.

ES: Al ajustar el bloqueo de leva, asegúrese de que la posición inicial sea correcta antes de insertar el enchufe rápido de conexión.

JP: カムロックを取り付けるときは、接続する QuickFit を挿入する前に、開始位置が正しいことを確認してください。

# NOTICE

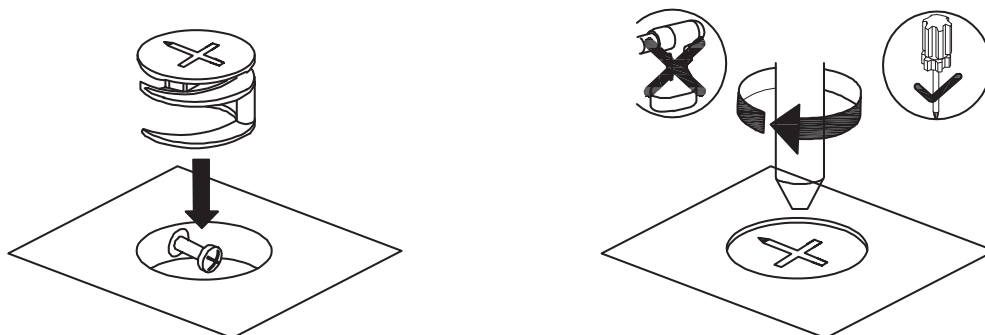

- EN: The quickfit head should be in the center of the cam lock when the two panels are joined. The cam lock should be inserted before the QuickFit. Turn the cam lock clockwise to tighten.
- DE: Der Quickfit-Kopf sollte sich in der Mitte des Nockensperres befinden, wenn die beiden Platten verbunden sind. Die Nockensperre sollte vor dem Quickfit eingesetzt werden. Drehen Sie die Nockensperre im Uhrzeigersinn, um sie zu straffen.
- FR: La tête de montage rapide doit être au centre de la verrouillage à came lorsque les deux panneaux sont joints. Le verrou à came doit être inséré avant le quickfit. Tournez le verrouillage de la cam dans le sens horaire pour serrer.
- IT: La testa QuickFit dovrebbe essere al centro della serratura a camma quando i due pannelli sono uniti. La serratura della camma deve essere inserita prima del quickfit. Gira il blocco della cam in senso orario per stringere.
- ES: La cabeza de ajuste rápido debe estar en el centro del bloqueo de leva cuando los dos paneles se unen. El bloqueo de leva debe insertarse antes del ajuste rápido. Gire el bloqueo de leva en el sentido horario para apretarlo.
- JP: 2枚のパネルを接合する際、クイックフィットヘッドがカムロックの中央に位置するようにしてください。カムロックはクイックフィットより先に挿入してください。カムロックを時計回りに回して締め付けてください。

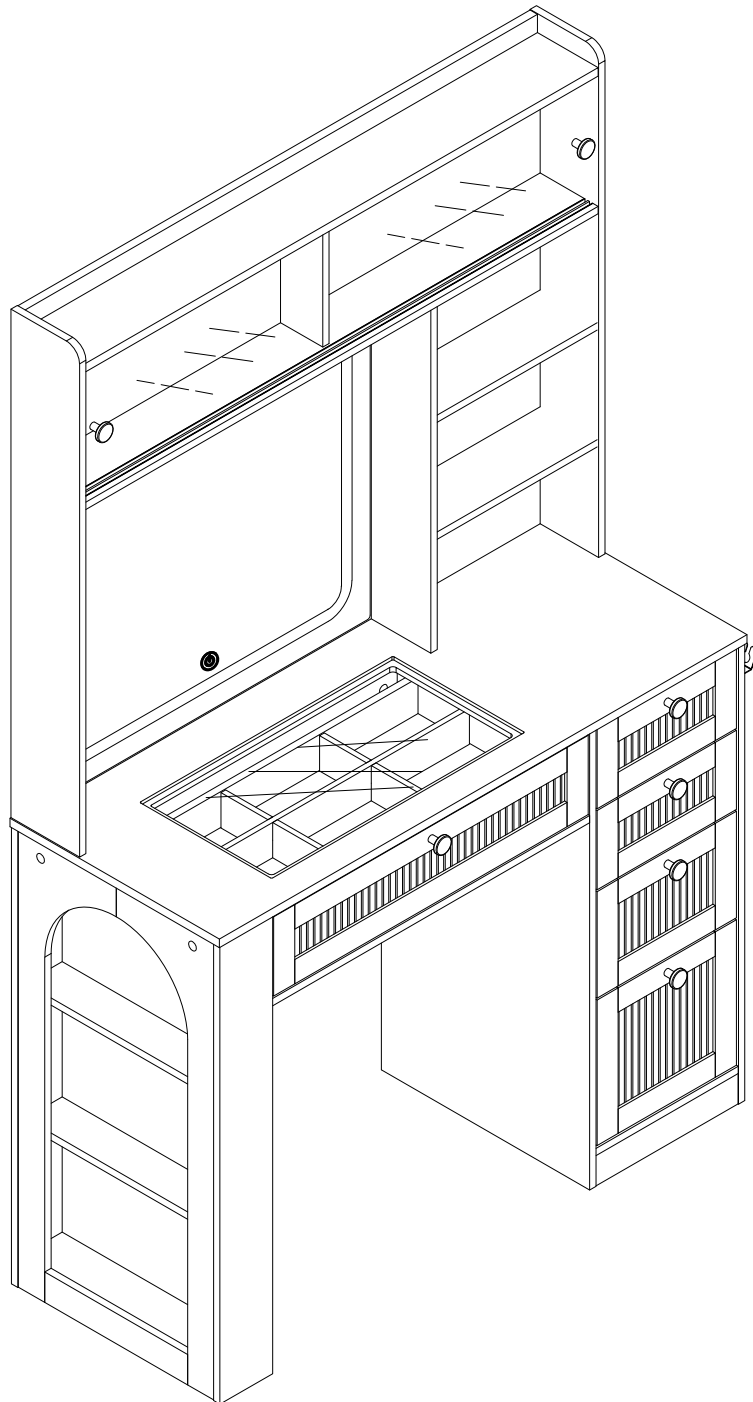

# EXPLODED

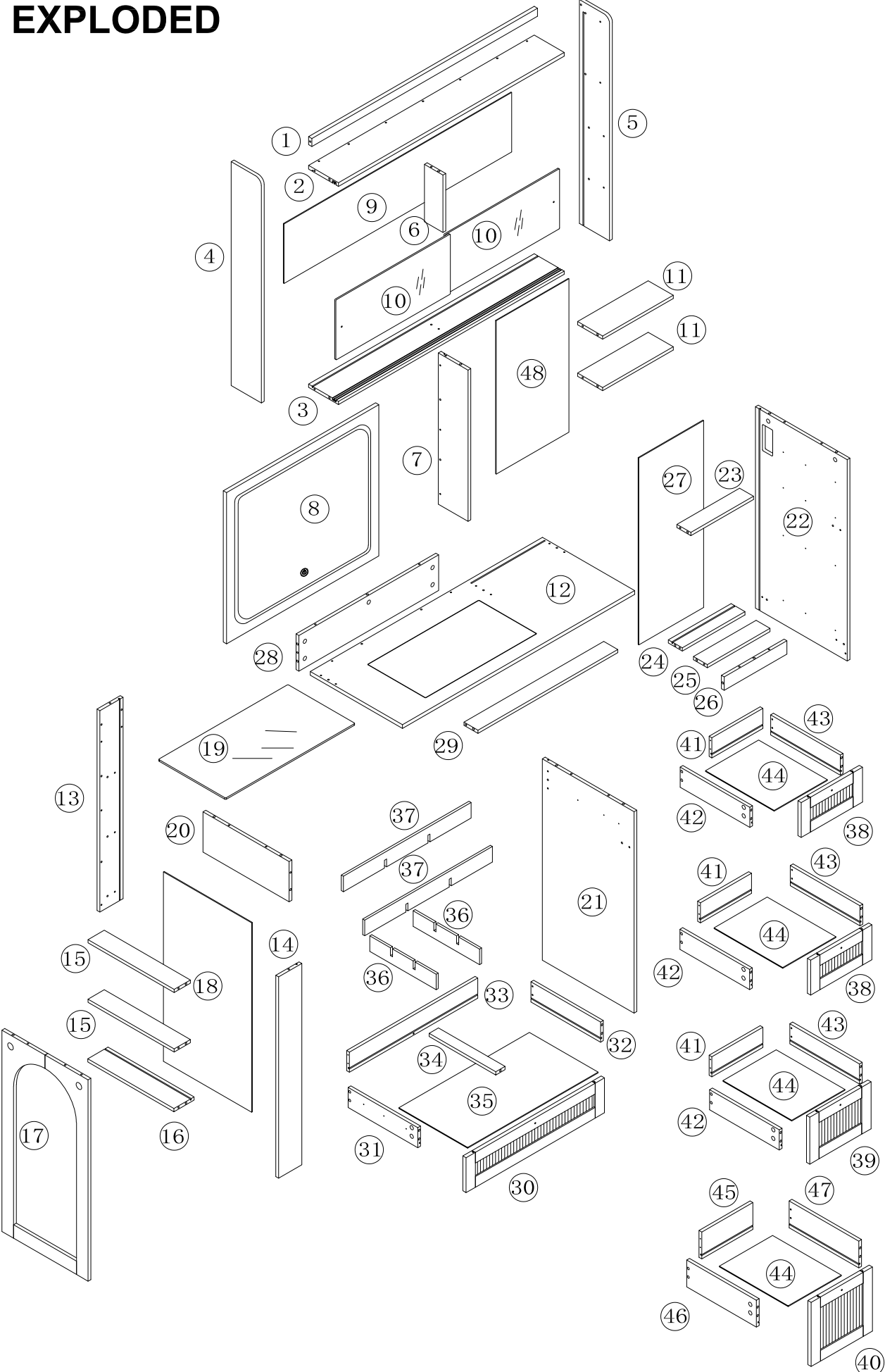

# PART LIST:

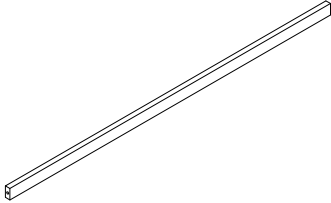
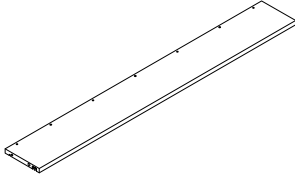
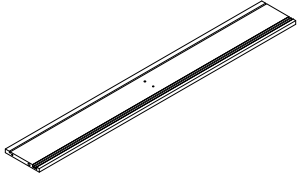
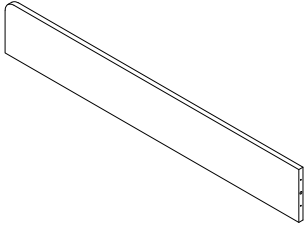
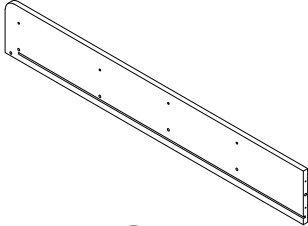
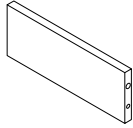
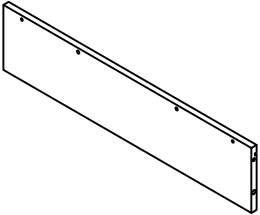
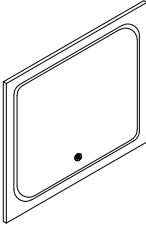
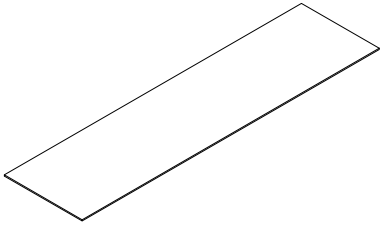
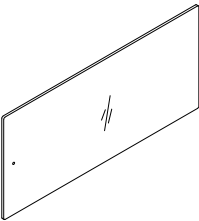
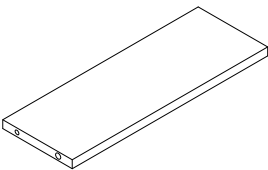
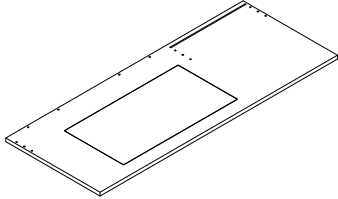
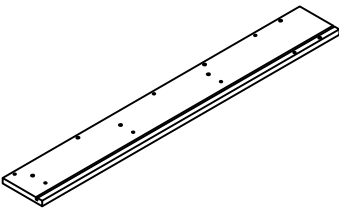
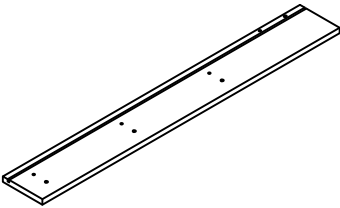
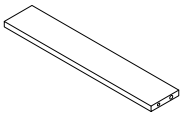
 <p>① X1</p>	 <p>② X1</p>	 <p>③ X1</p>
 <p>④ X1</p>	 <p>⑤ X1</p>	 <p>⑥ X1</p>
 <p>⑦ X1</p>	 <p>⑧ X1</p>	 <p>⑨ X1</p>
 <p>⑩ X2</p>	 <p>⑪ X2</p>	 <p>⑫ X1</p>
 <p>⑬ X1</p>	 <p>⑭ X1</p>	 <p>⑮ X2</p>

# PART LIST:

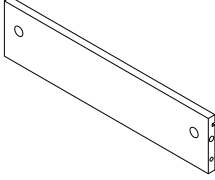
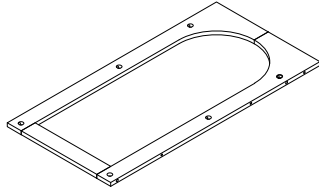
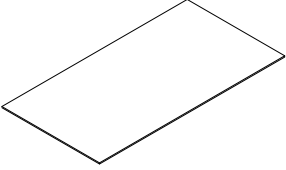
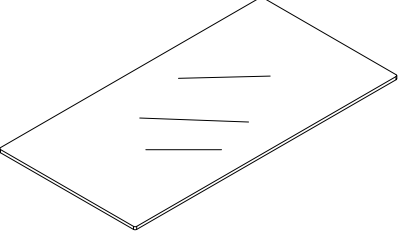
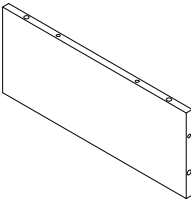
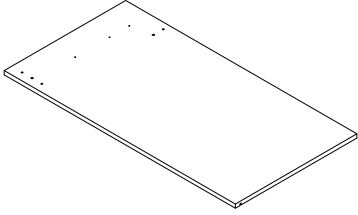
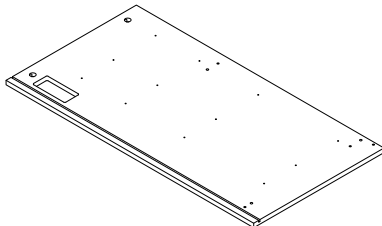
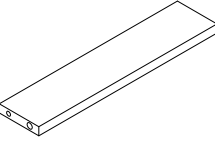
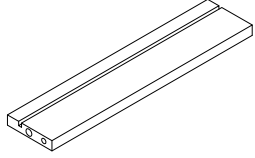
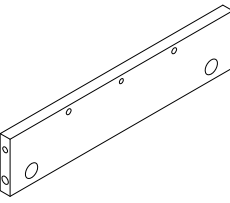
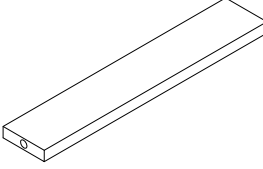
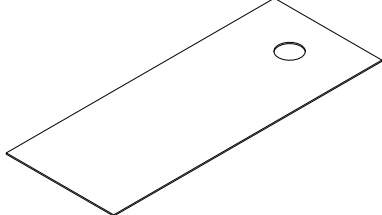
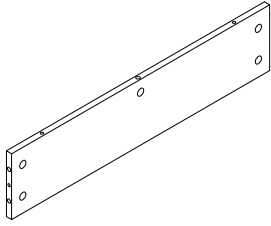
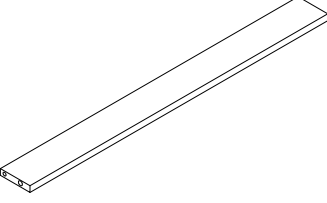
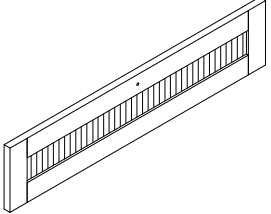
 <p>①⑥ X1</p>	 <p>①⑦ X1</p>	 <p>①⑧ X1</p>
 <p>①⑨ X1</p>	 <p>②⑦ X1</p>	 <p>②⑧ X1</p>
 <p>②② X1</p>	 <p>②③ X1</p>	 <p>②④ X1</p>
 <p>②⑤ X1</p>	 <p>②⑥ X1</p>	 <p>②⑦ X1</p>
 <p>②⑧ X1</p>	 <p>②⑨ X1</p>	 <p>③⑦ X1</p>

# PART LIST:

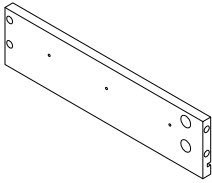
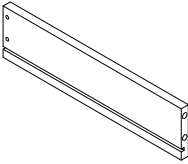
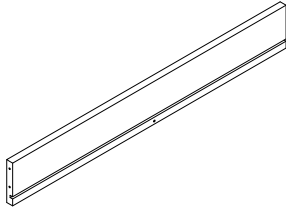
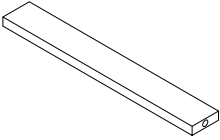
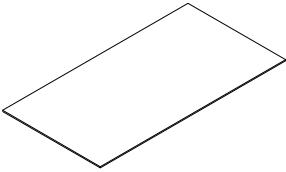
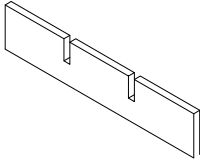
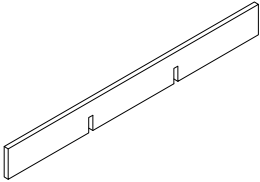
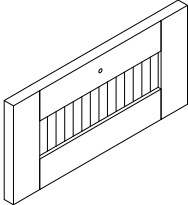
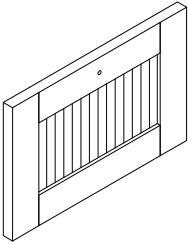
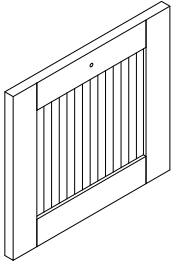
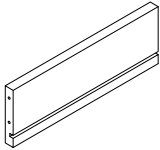
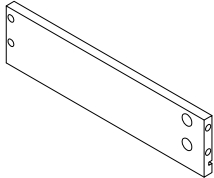
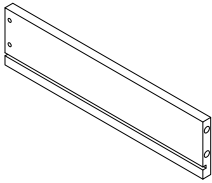
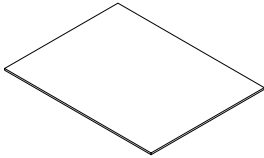
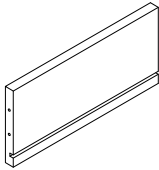
 <p>③① X1</p>	 <p>③② X1</p>	 <p>③③ X1</p>
 <p>③④ X1</p>	 <p>③⑤ X1</p>	 <p>③⑥ X2</p>
 <p>③⑦ X2</p>	 <p>③⑧ X2</p>	 <p>③⑨ X1</p>
 <p>④① X1</p>	 <p>④② X3</p>	 <p>④③ X3</p>
 <p>④④ X3</p>	 <p>④⑤ X4</p>	 <p>④⑥ X1</p>

**PART LIST:**

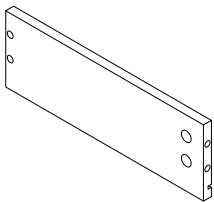

④⑥ X1

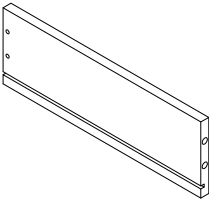



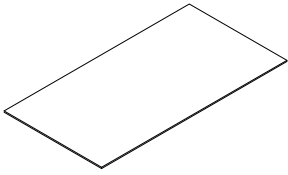





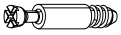



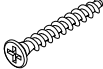

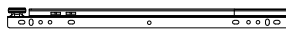

④⑦ X1

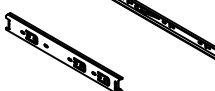

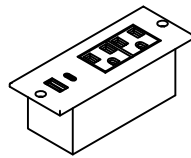
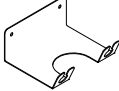
④⑧ X1

# HARDWARE LIST:

<p style="text-align: center;">Ⓐ</p>  x76+2 $\phi 6 * 35 \text{mm}$	<p style="text-align: center;">Ⓑ</p>  x76+2 $\phi 15 * 9.5 \text{mm}$	<p style="text-align: center;">Ⓒ</p>  x65+2 $\phi 6 * 30 \text{mm}$
<p style="text-align: center;">Ⓓ</p>  x77+2 $\phi 3 * 12 \text{mm}$	<p style="text-align: center;">Ⓔ</p>  x33+1 $\phi 4 * 32$	<p style="text-align: center;">Ⓕ</p>  x27+1
<p style="text-align: center;">Ⓖ</p> <p style="text-align: center;">4PCS</p>  <p style="text-align: center;"><math>300 * 35 * 1.0 \text{mm}</math></p>	<p style="text-align: center;">Ⓖ</p> <p style="text-align: center;">4PCS</p>  <p style="text-align: center;"><math>300 * 35 * 1.0 \text{mm}</math></p>	<p style="text-align: center;">Ⓖ</p> <p style="text-align: center;">4PCS</p>  <p style="text-align: center;"><math>300 * 35 * 1.0 \text{mm}</math></p>
<p style="text-align: center;">Ⓙ</p> <p style="text-align: center;">4PCS</p>  <p style="text-align: center;"><math>300 * 35 * 1.0 \text{mm}</math></p>	<p style="text-align: center;">Ⓚ</p> <p style="text-align: center;">2PCS</p>  <p style="text-align: center;"><math>300 * 35 * 1.0 \text{mm}</math></p>	<p style="text-align: center;">Ⓛ</p>  x14+1 $\phi 3 * 12 \text{mm}$
<p style="text-align: center;">Ⓜ</p>  x1	<p style="text-align: center;">Ⓝ</p>  x1 $105 * 115 * 1.0 \text{mm}$	<p style="text-align: center;">Ⓞ</p>  7PCS
<p style="text-align: center;">Ⓟ</p>  x2 $\phi 4 * 9 \text{mm}$	<p style="text-align: center;">Ⓠ</p>  x5 $\phi 4 * 18 \text{mm}$	<p style="text-align: center;">Ⓡ</p>  x1

# HARDWARE LIST:

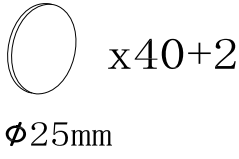
<p style="text-align: center;">(S)</p>  <p style="text-align: center;">x40+2 Ø25mm</p>	<p style="text-align: center;">(T)</p>  <p style="text-align: center;">2 pcs. Tipping Restraint Hardware</p>	<p style="text-align: center;">(U)</p> 

# Step 1

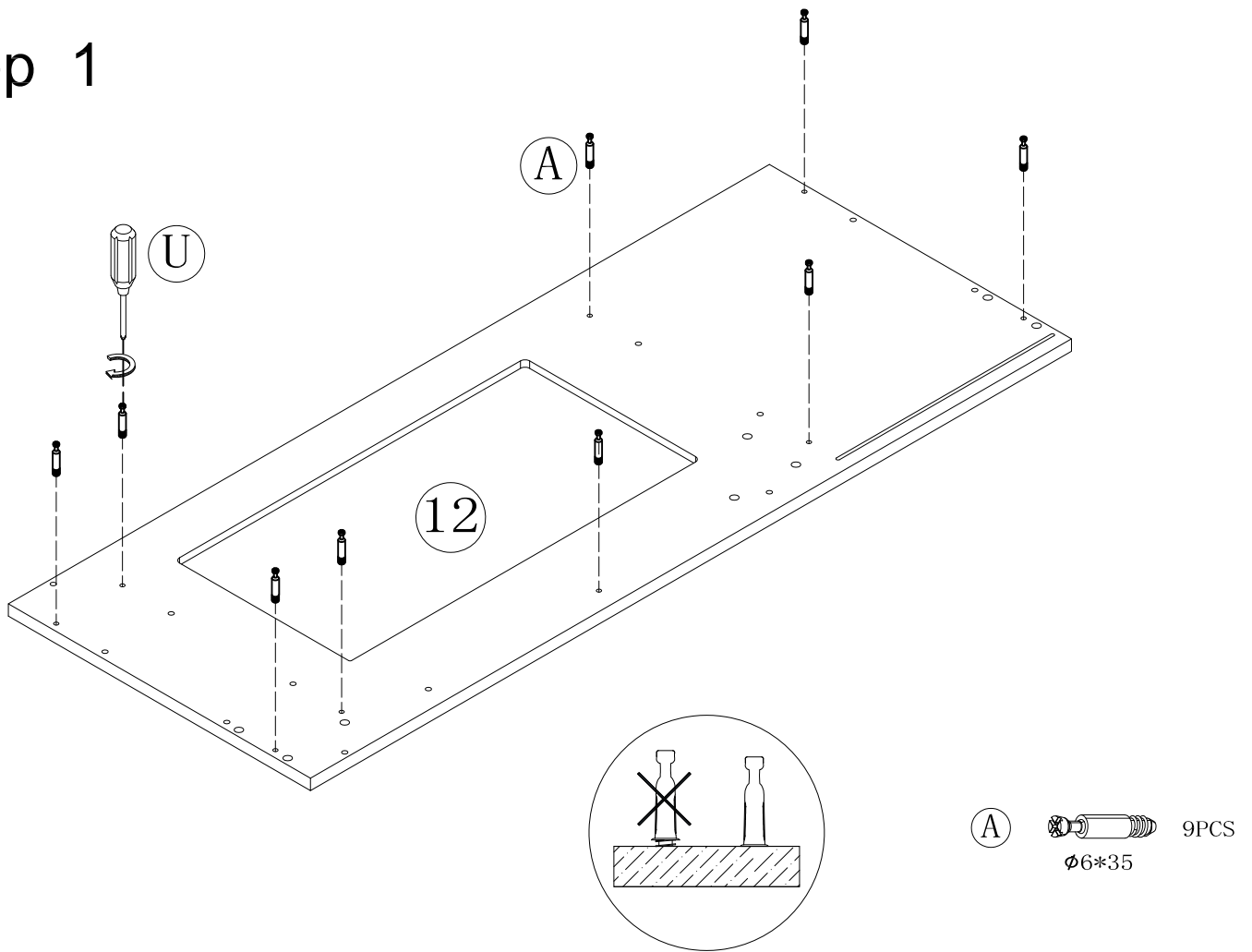

# Step 2

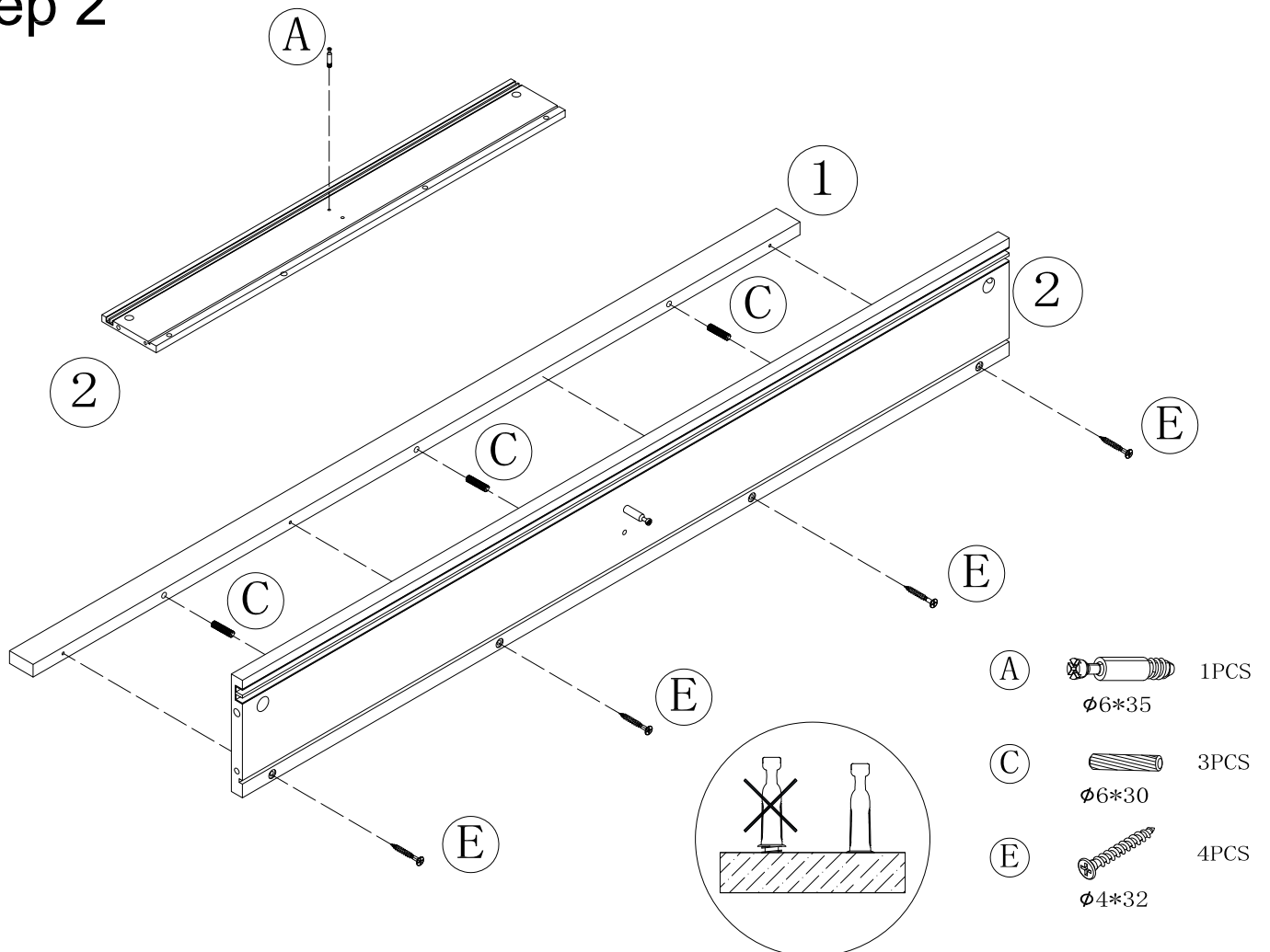



# Step 5

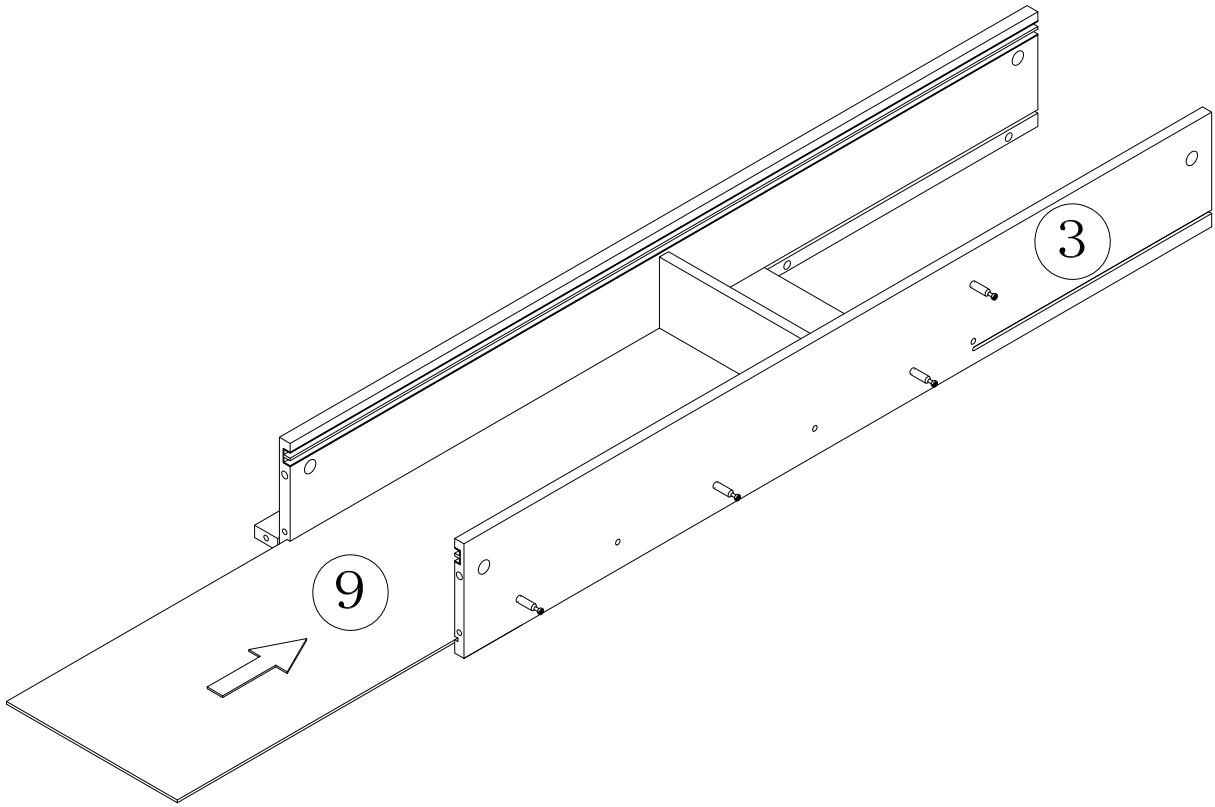

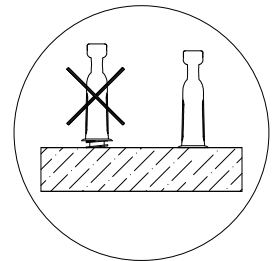
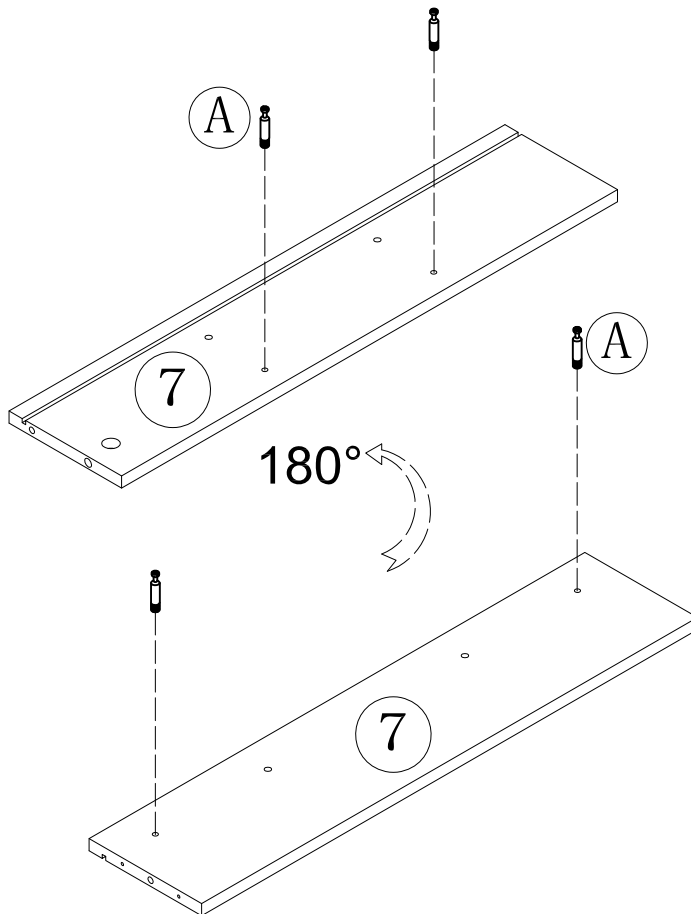

# Step 6

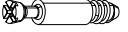

(A)  4PCS  
Ø6\*35

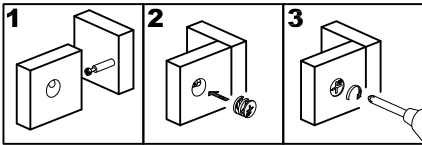
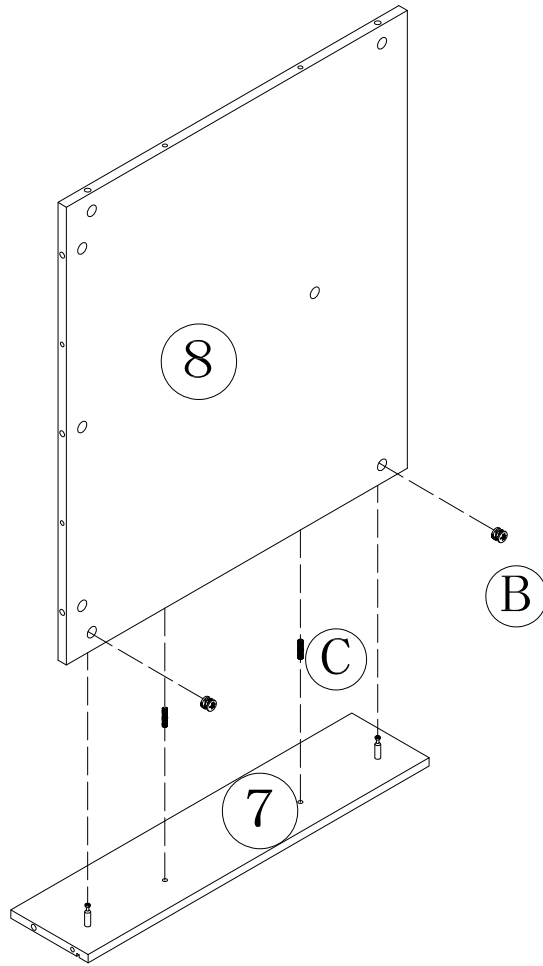

# Step 7



- (B)  2PCS  
Ø15\*9.5
- (C)  2PCS  
Ø6\*30

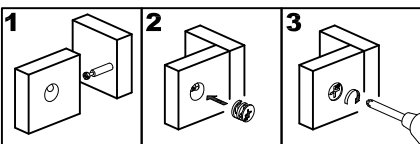
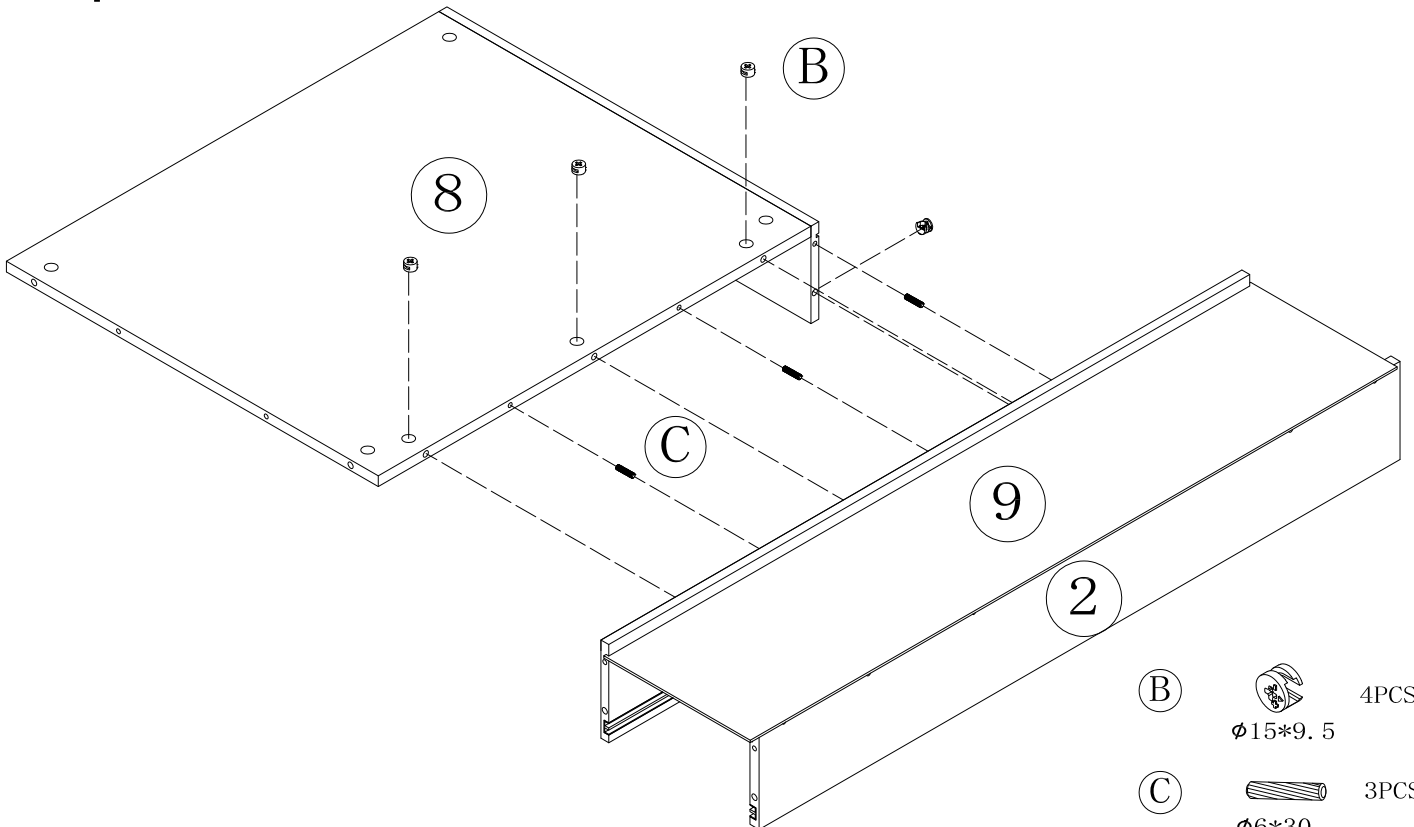

# Step 8

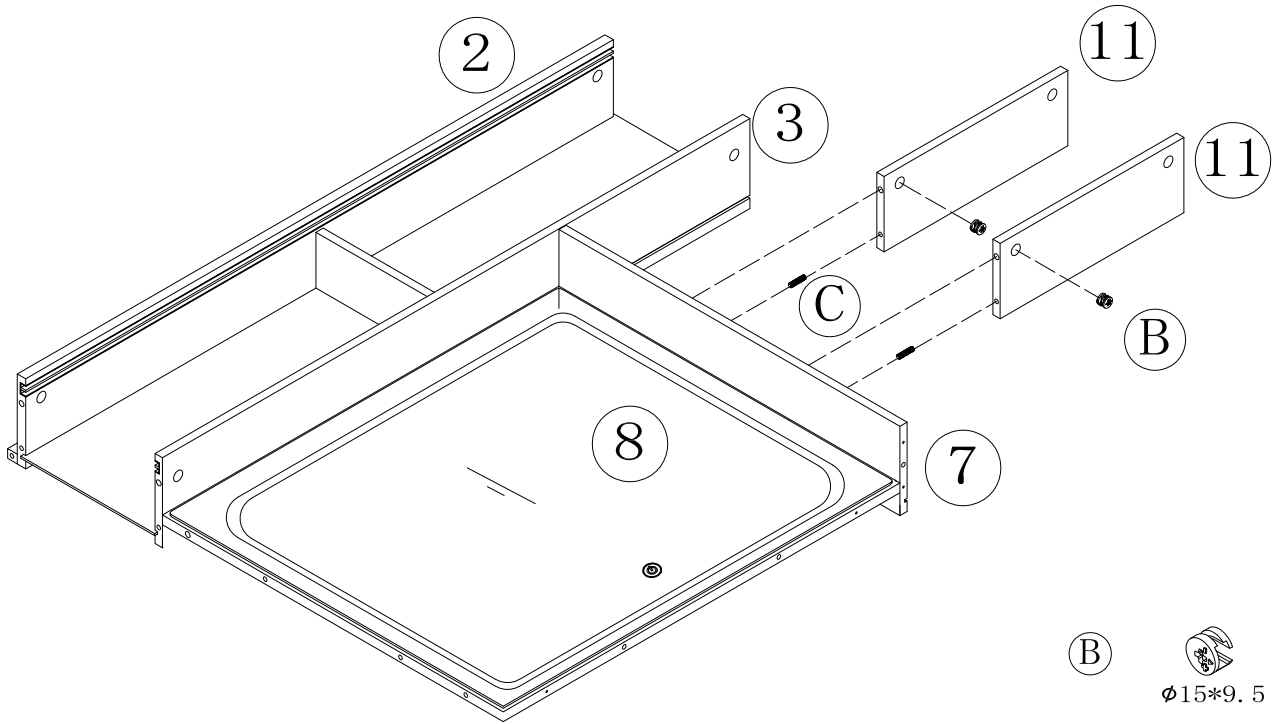

- (B)  4PCS  
Ø15\*9.5
- (C)  3PCS  
Ø6\*30

# Step 9



- (B)  2PCS  
 $\phi 15 * 9.5$
- (C)  2PCS  
 $\phi 6 * 30$

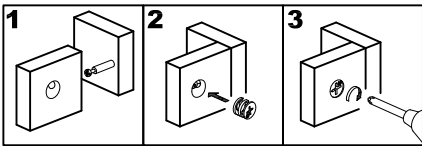

# Step 10

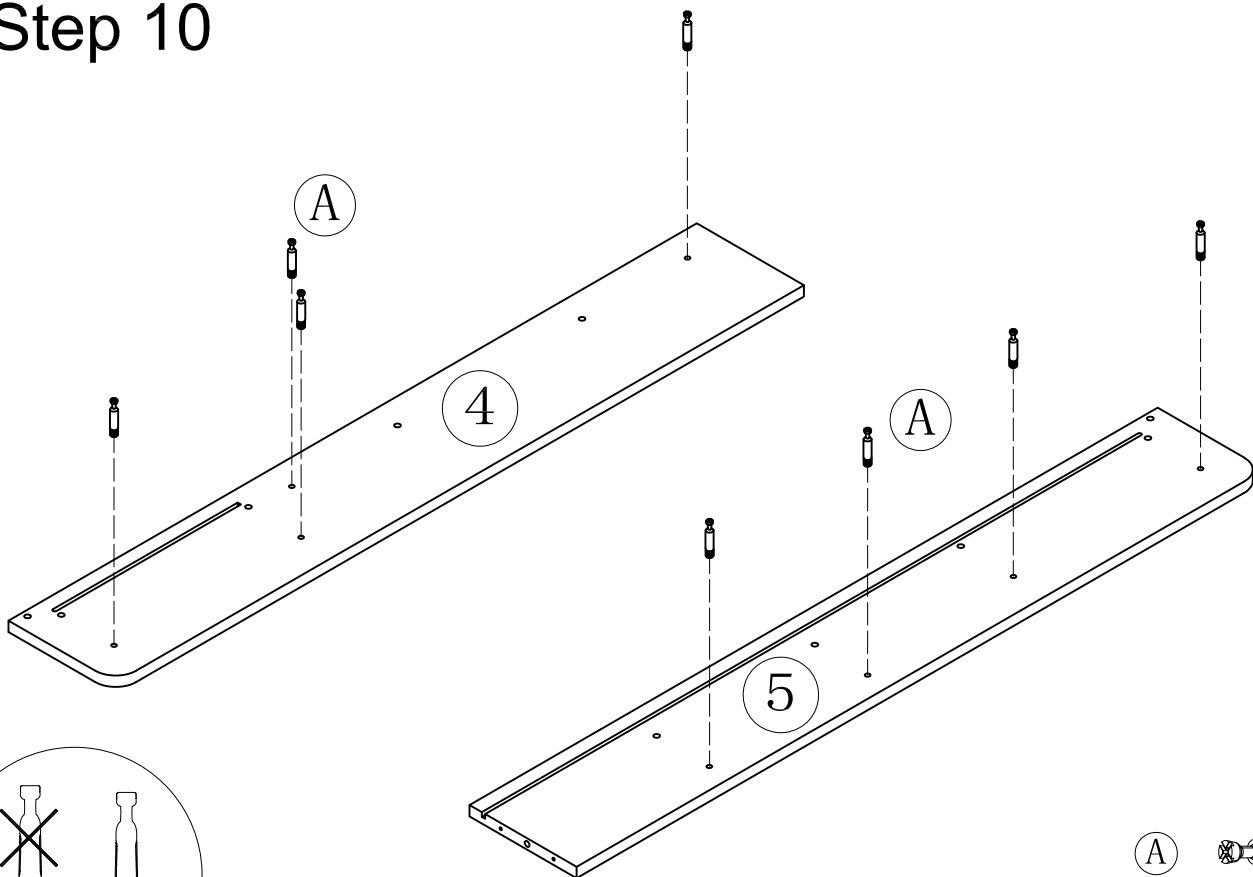

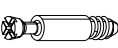

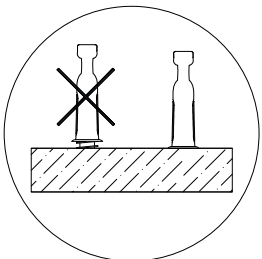
- (A)  8PCS  
 $\phi 6 * 35$

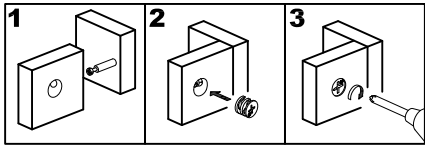
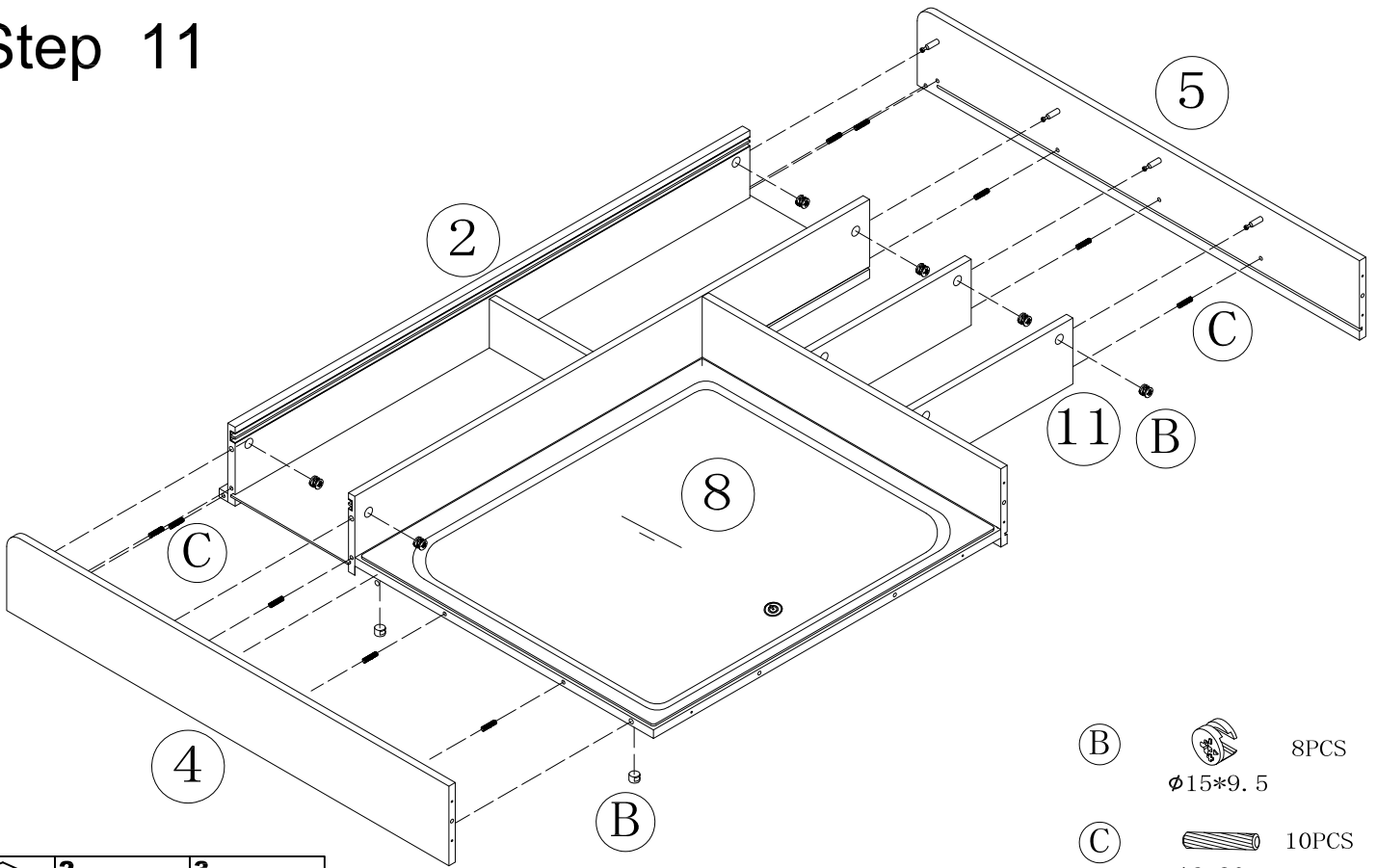

# Step 11



- (B)  8PCS  
Ø15\*9.5
- (C)  10PCS  
Ø6\*30

# Step 12

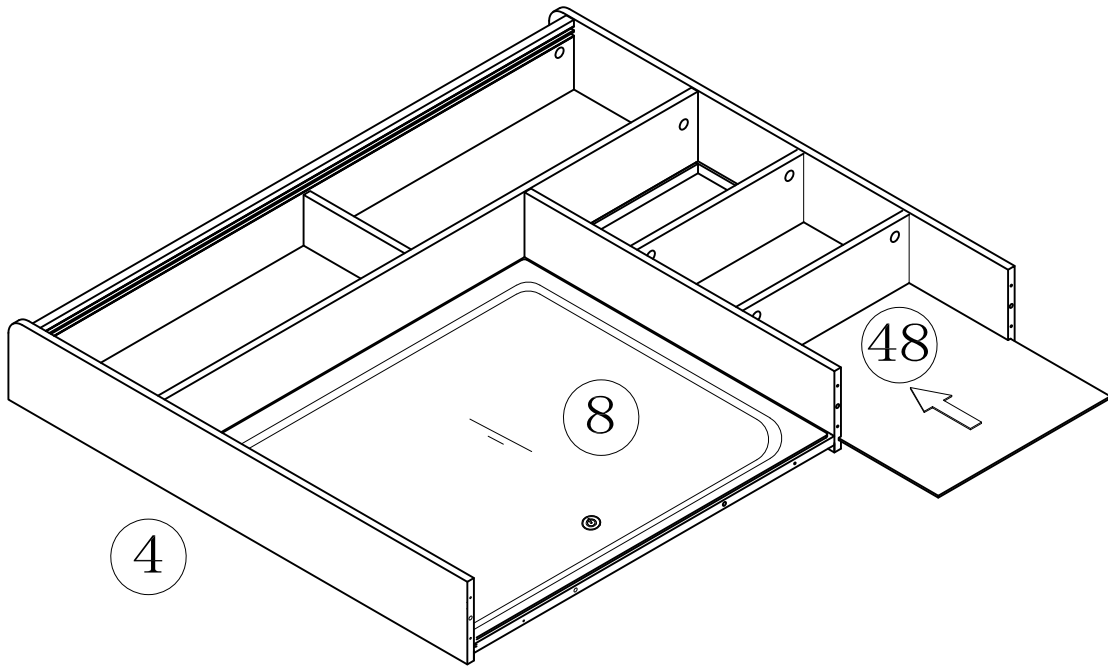

# Step 13

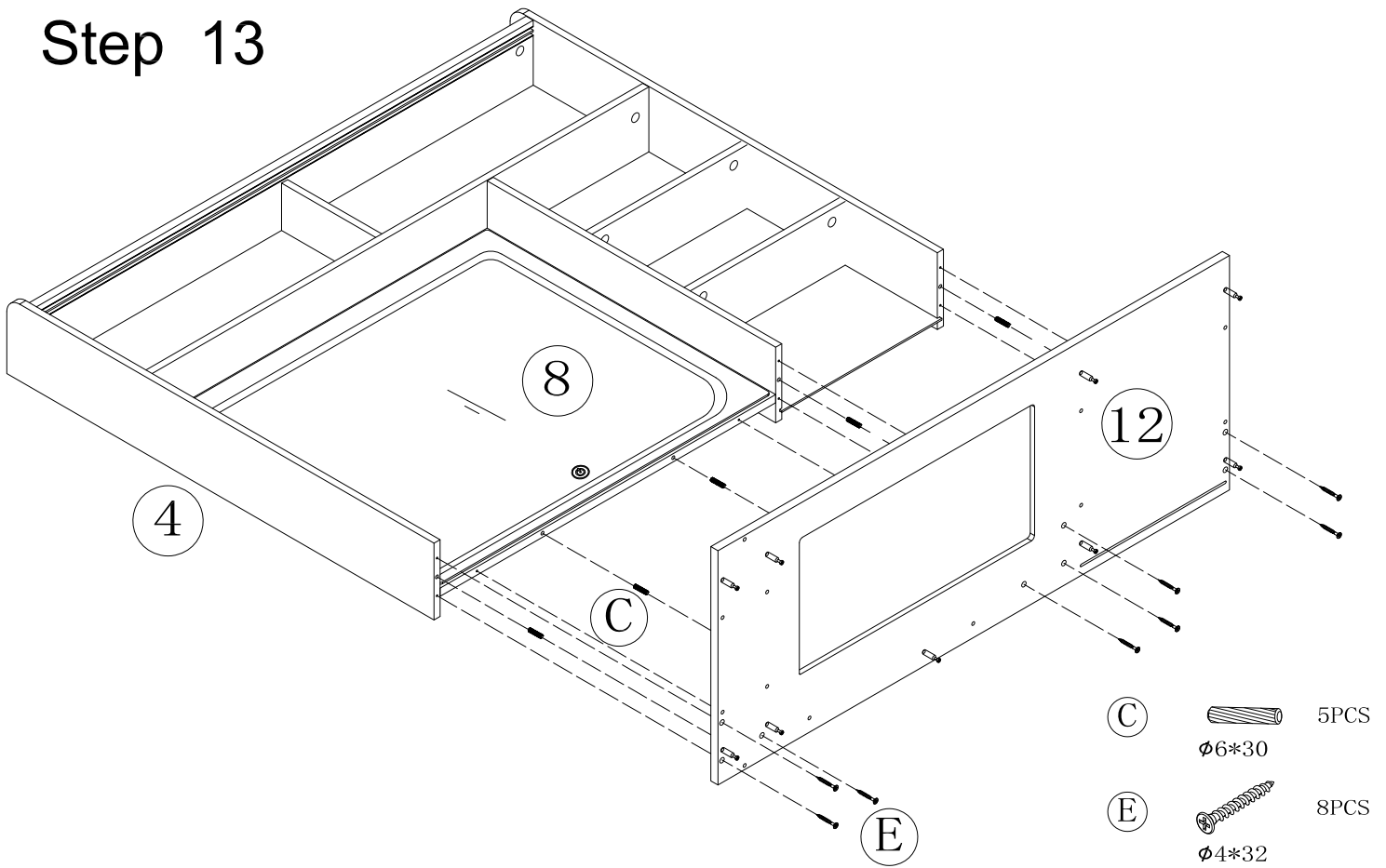

# Step 14

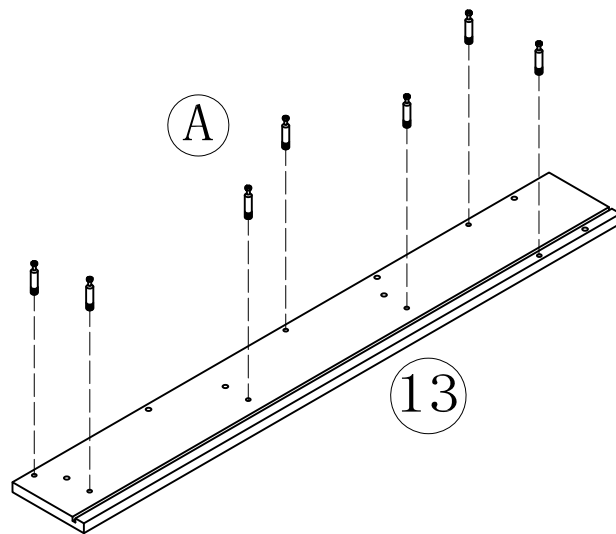

- (A)  $\phi 6 \times 35$  7PCS

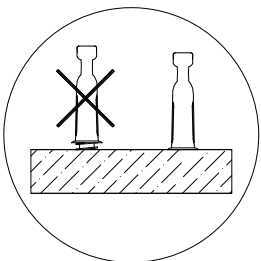

# Step 15

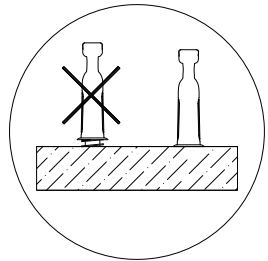
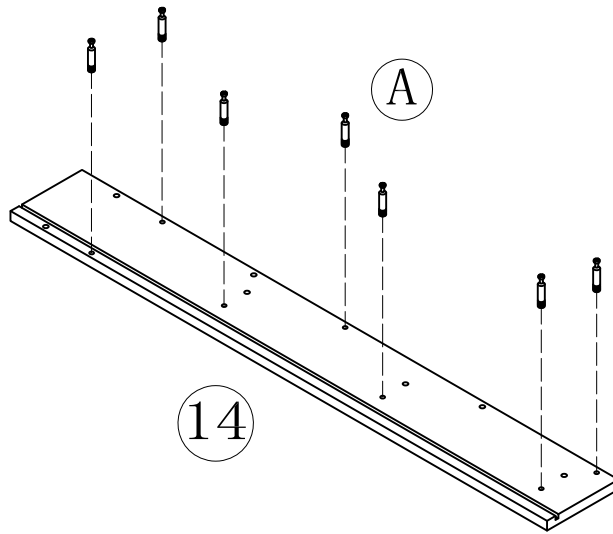

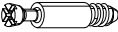

Ⓐ  7PCS  
φ6\*35

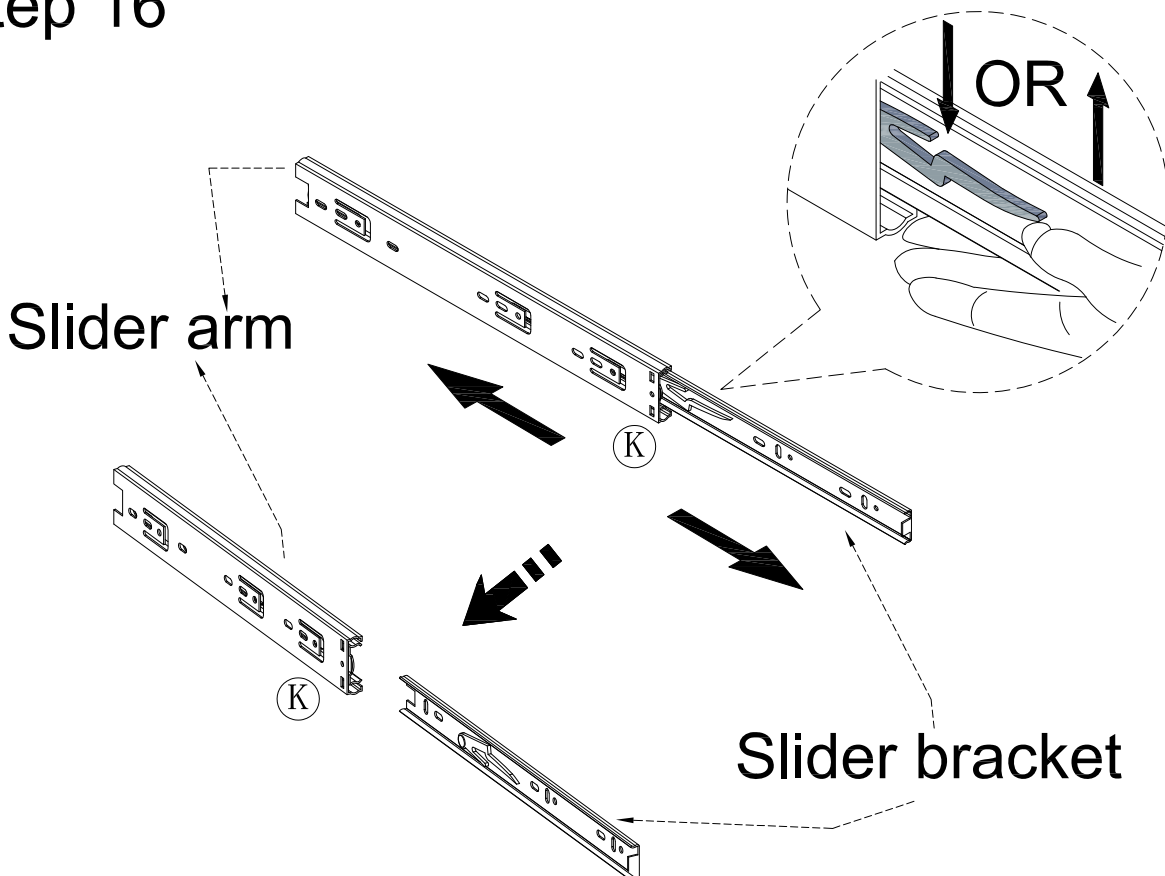
# Step 16



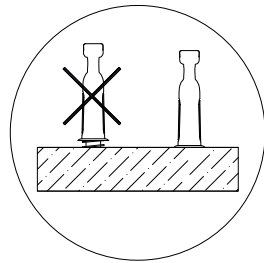
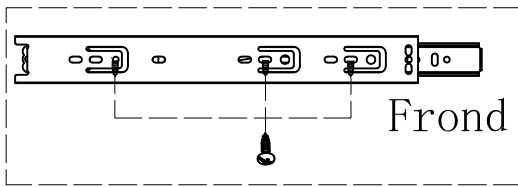
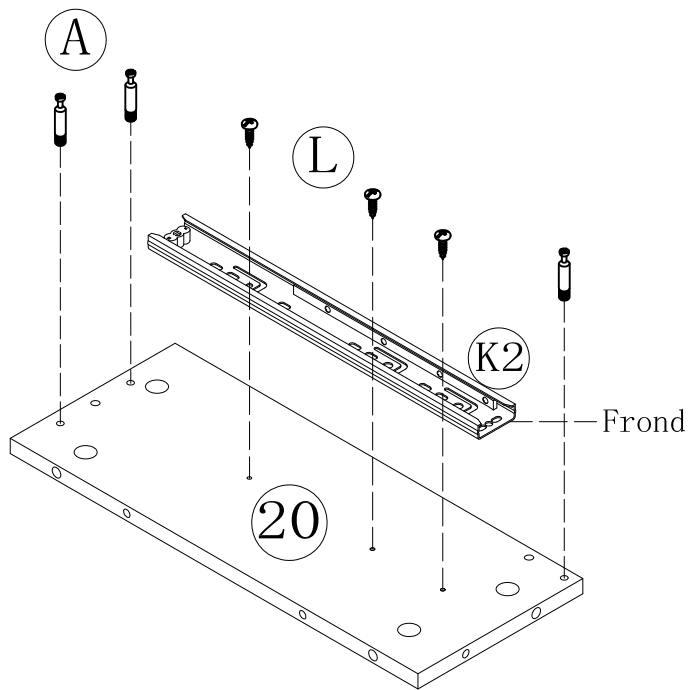

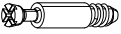
# Step 17

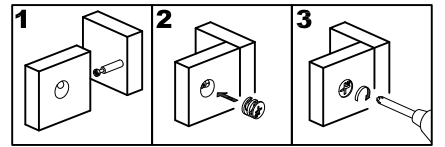
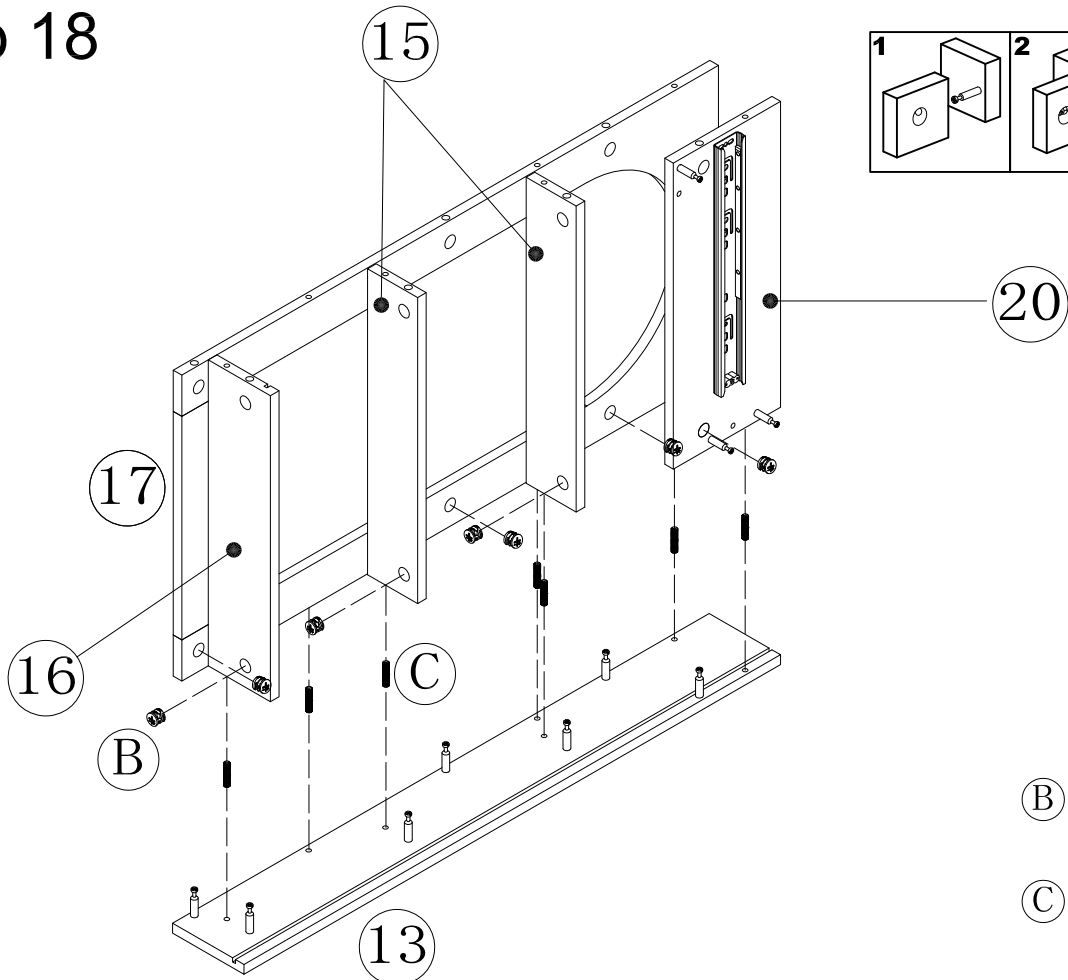

- (A)  3PCS  
Ø6\*35
- (L)  3PCS  
Ø3\*12
- (K2)  1PCS  
300\*35\*1.0

# Step 18



- (B)  7PCS  
Ø15\*9.5
- (C)  7PCS  
Ø6\*30

# Step 19

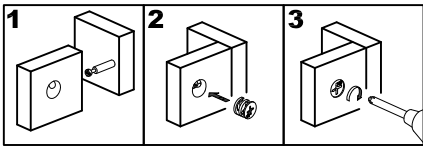
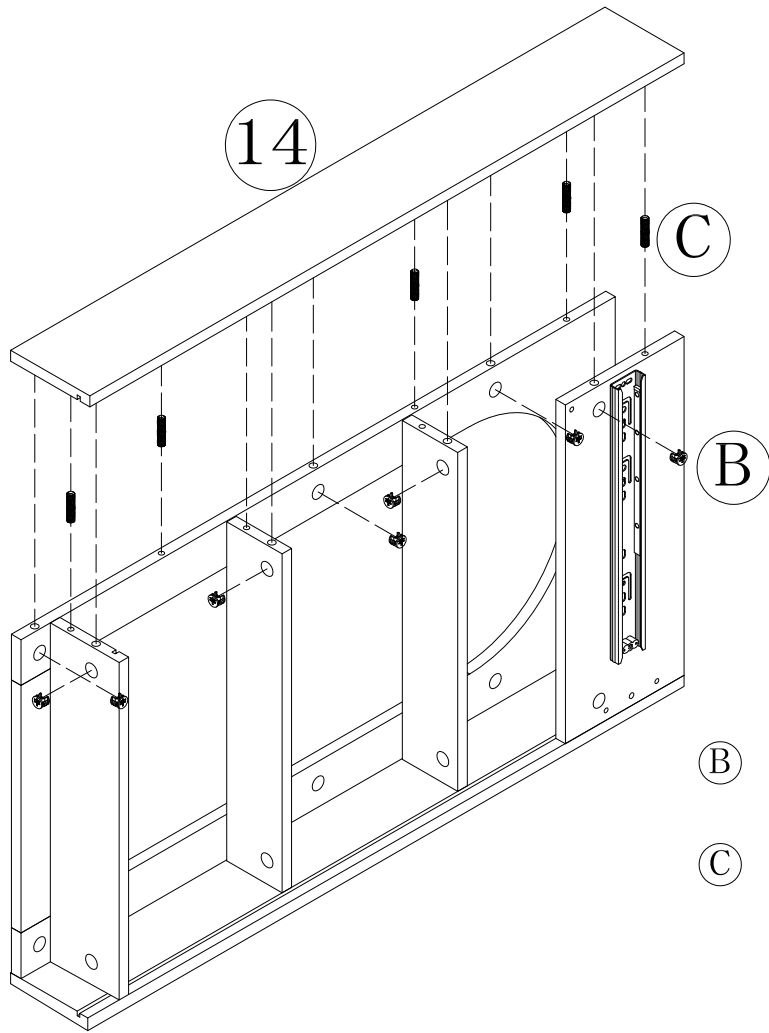



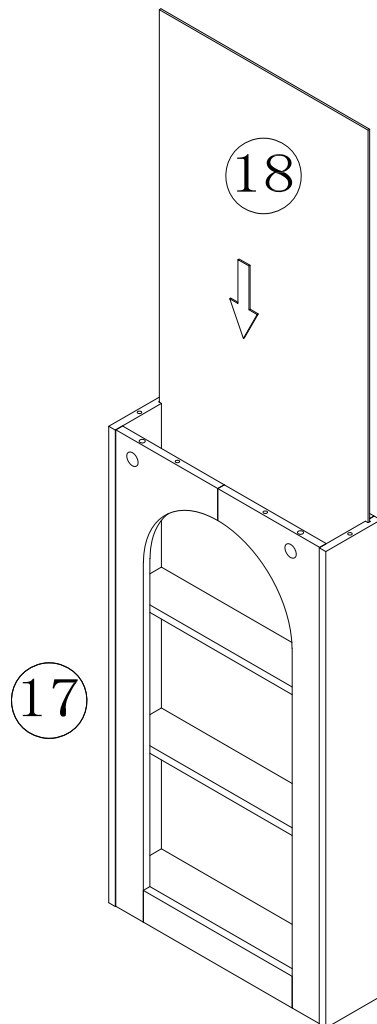

# Step 20

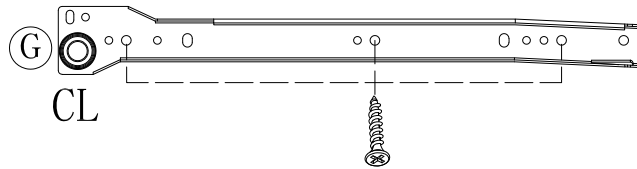
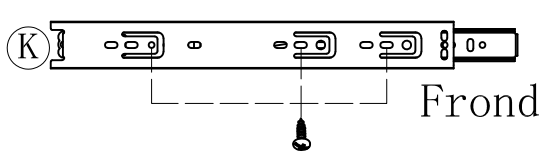
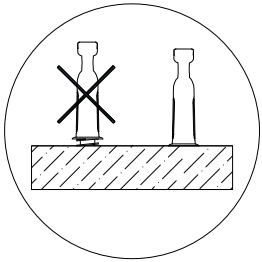
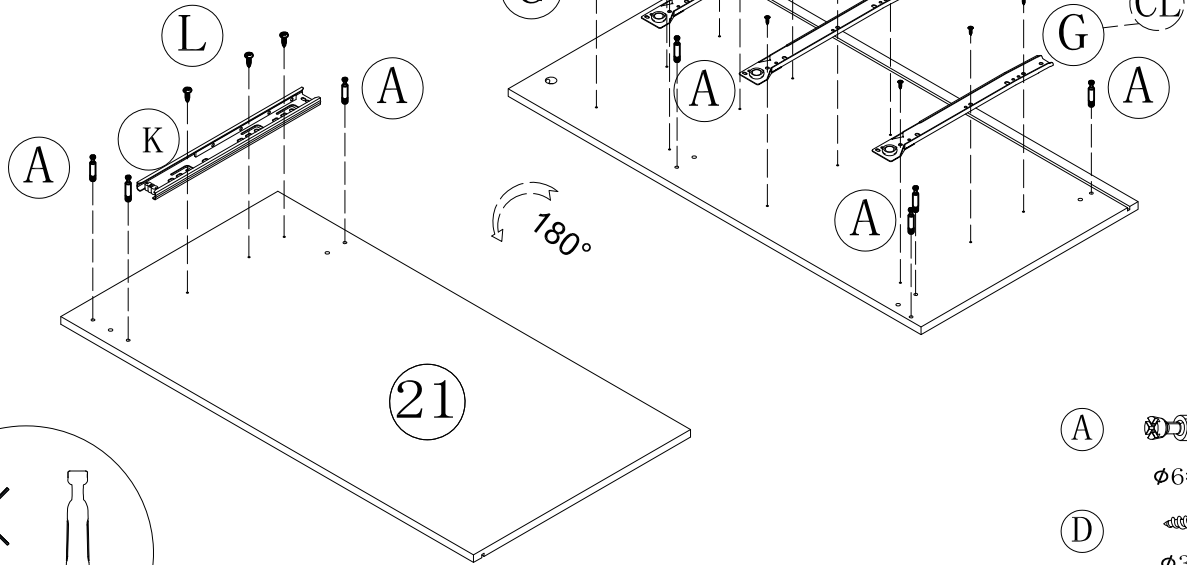

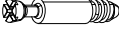

# Step 21

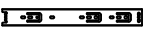

- (A)  7PCS  
Ø6\*35
- (D)  12PCS  
Ø3\*12
- (L)  3PCS  
Ø3\*12
- (G)  4PCS  
CL  
300\*35\*1.0
- (K)  1PCS  
300\*35\*1.0

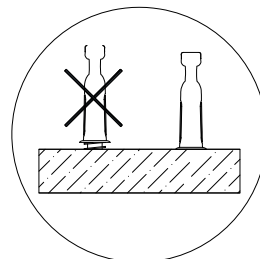
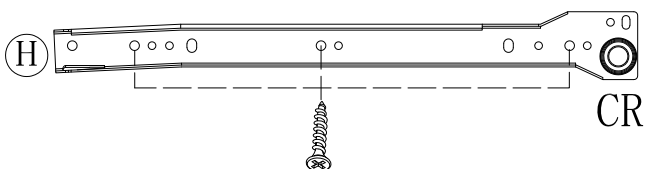
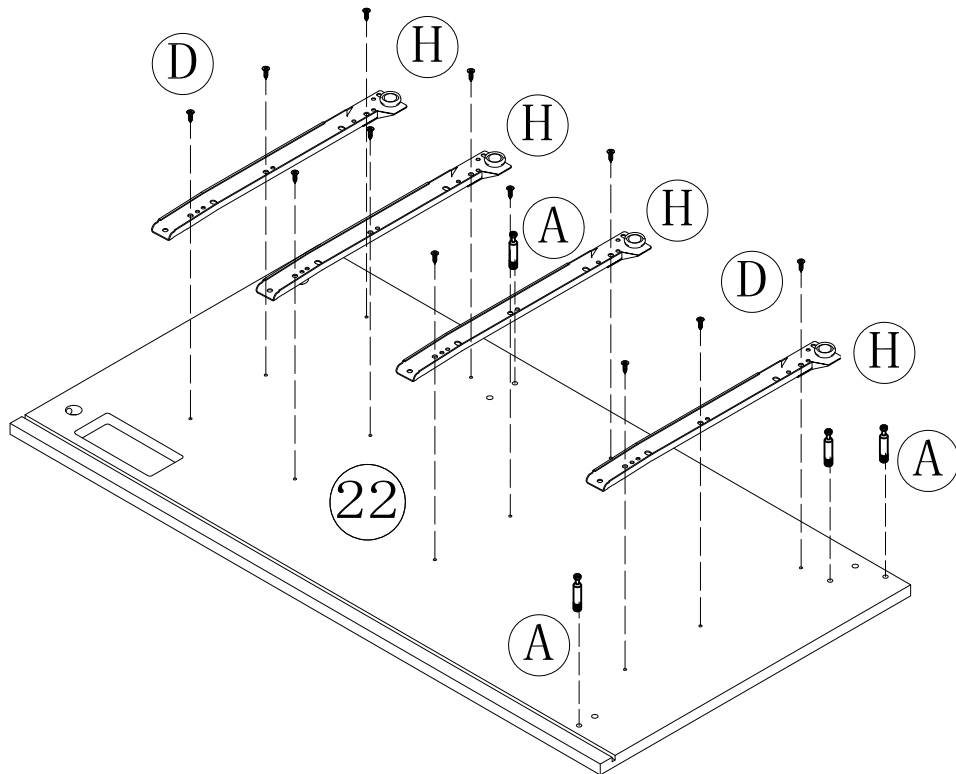
# Step 22

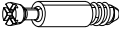

- (A)  4PCS  
Ø6\*35
- (D)  12PCS  
Ø3\*12
- (H)  4PCS  
CR  
300\*35\*1.0

# Step 23

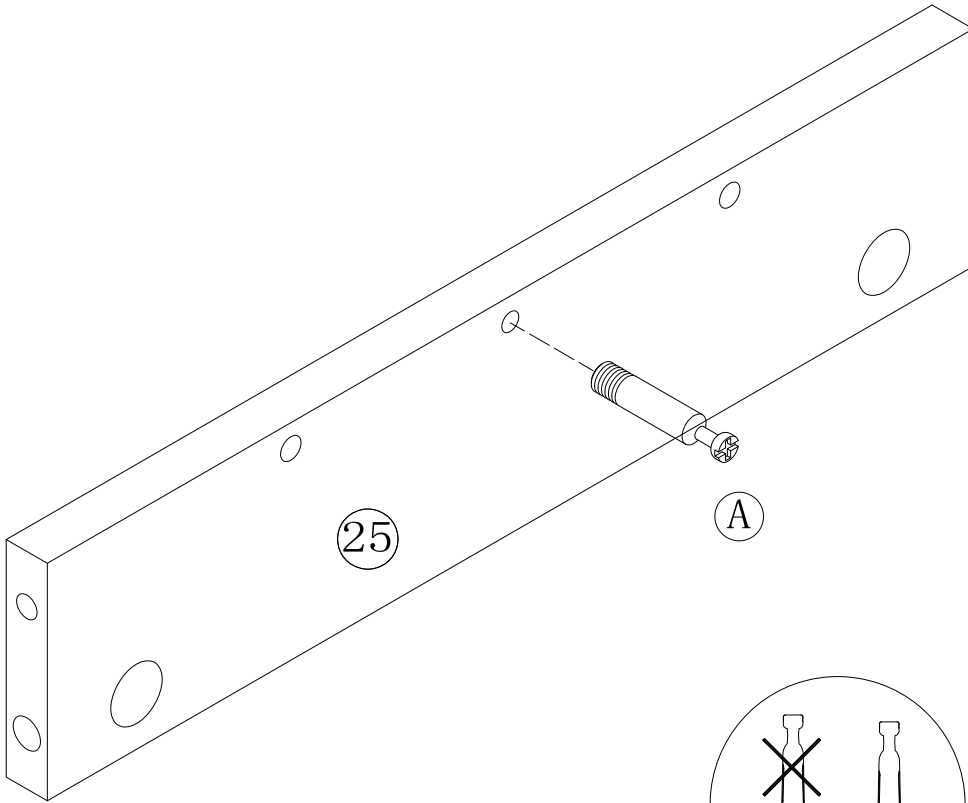

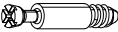

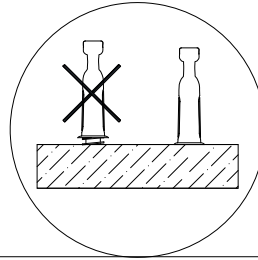
(A)  1PCS  
Ø6\*35

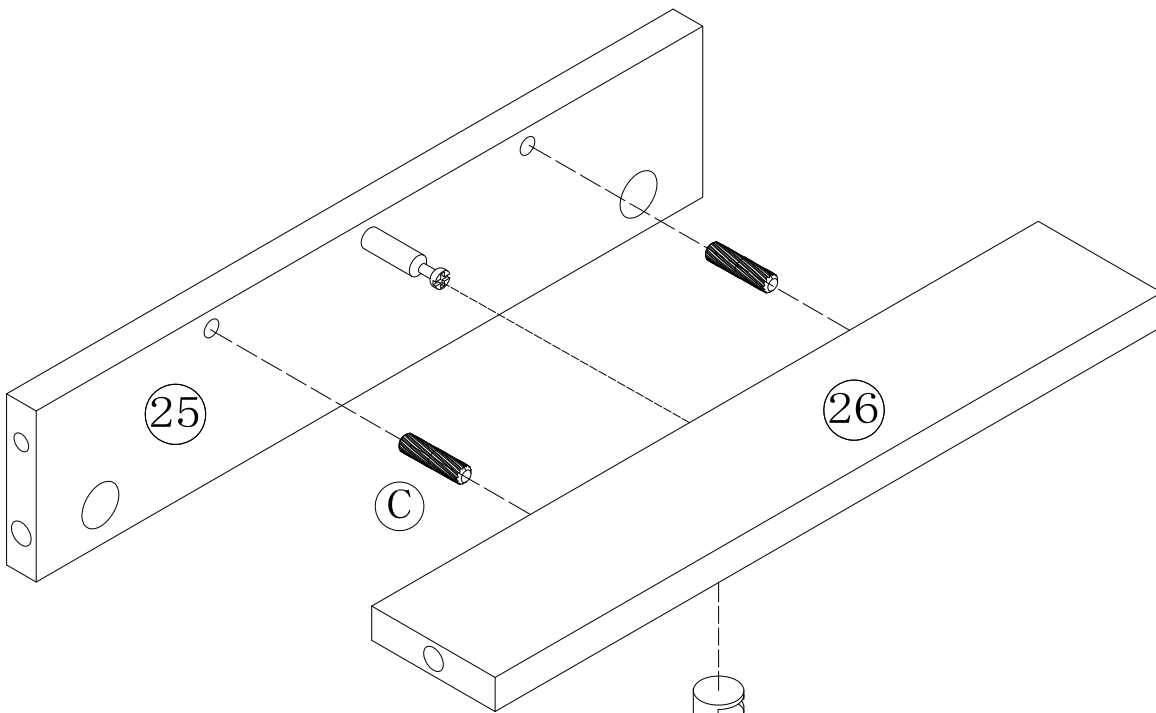

# Step 24



(B)  1PCS  
Ø15\*9.5

(C)  2PCS  
Ø6\*30

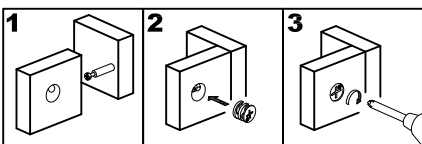

# Step 25

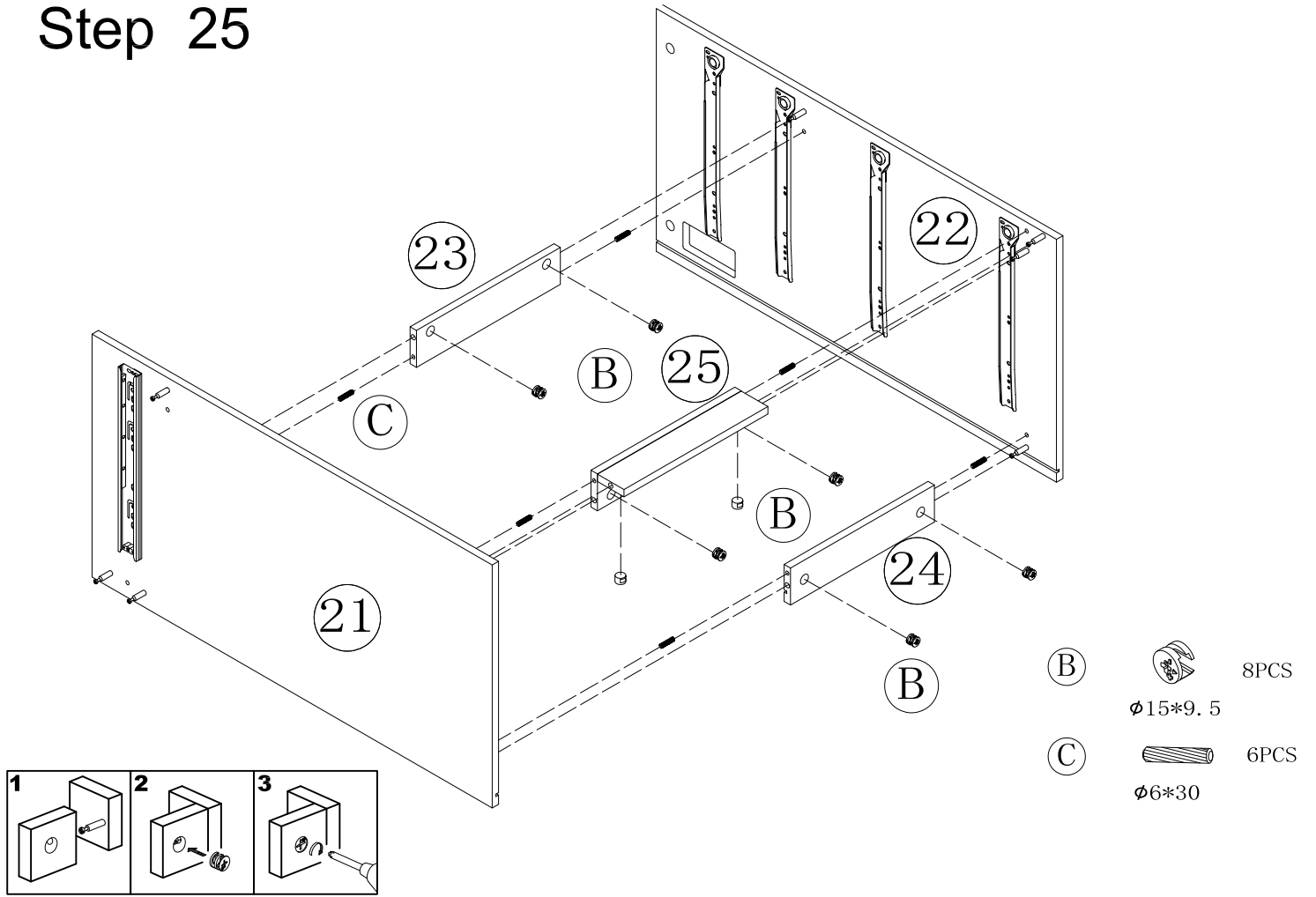

# Step 26

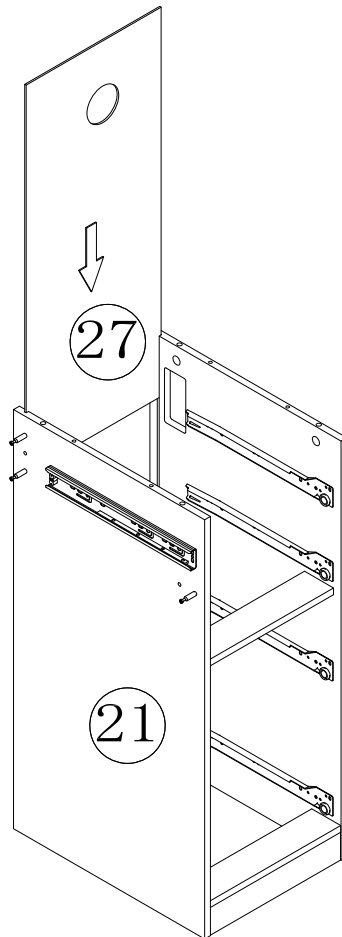

# Step 27

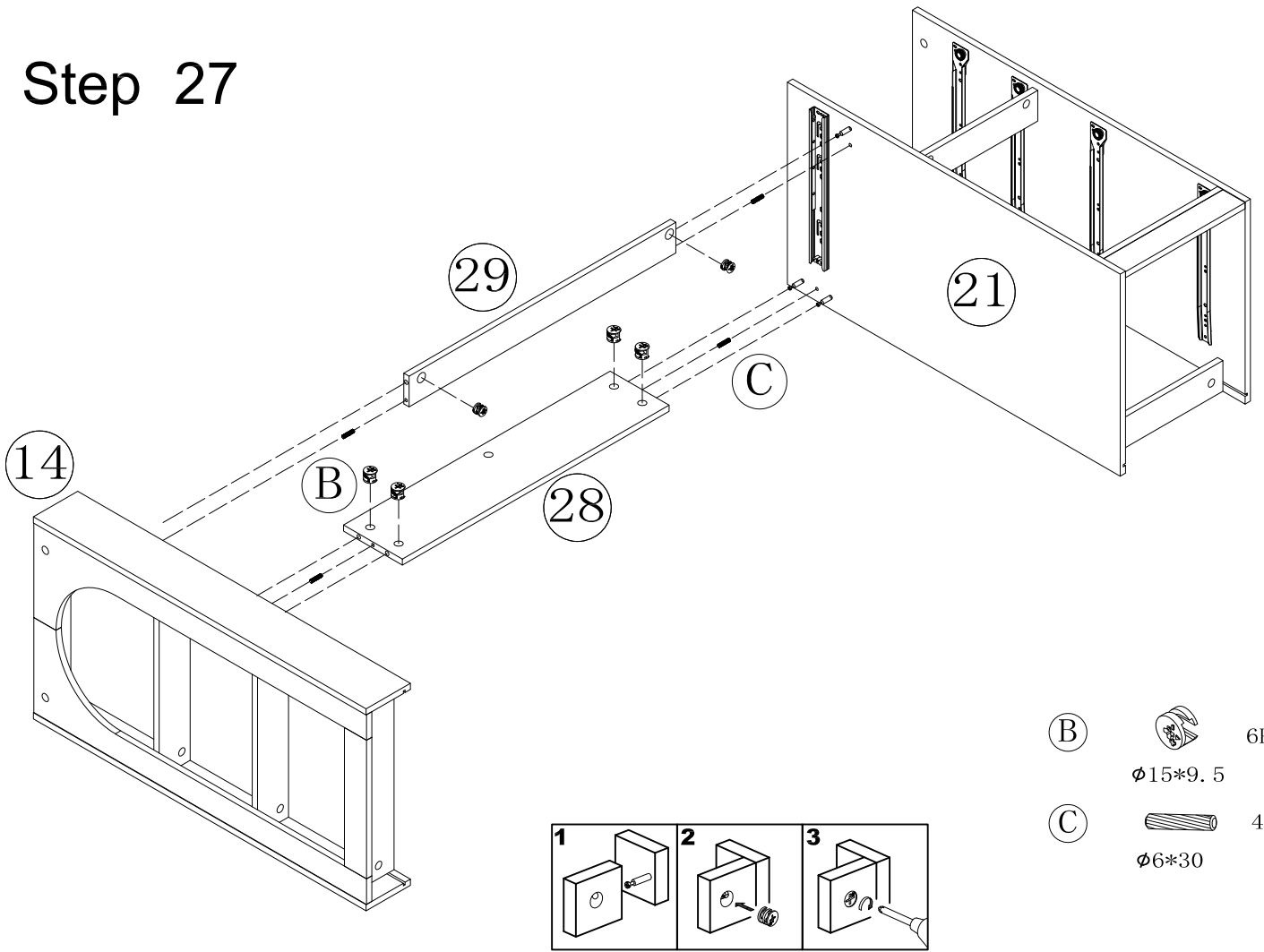

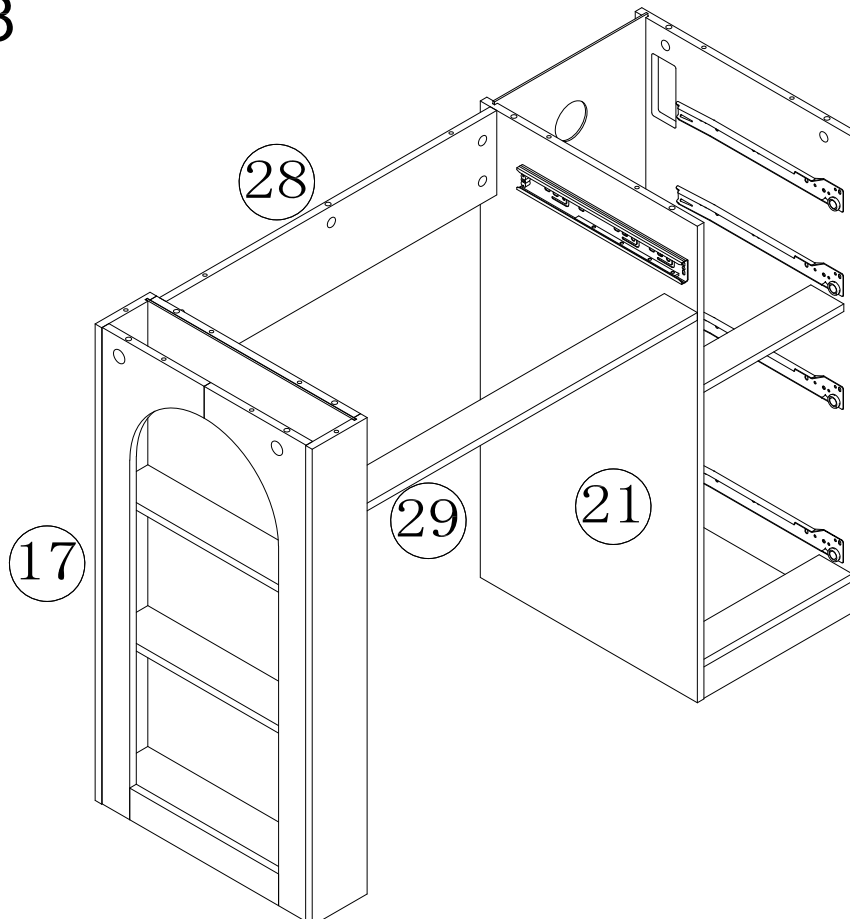

# Step 28

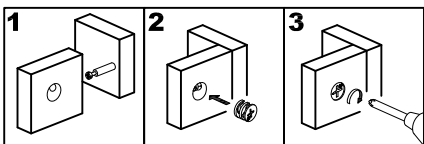
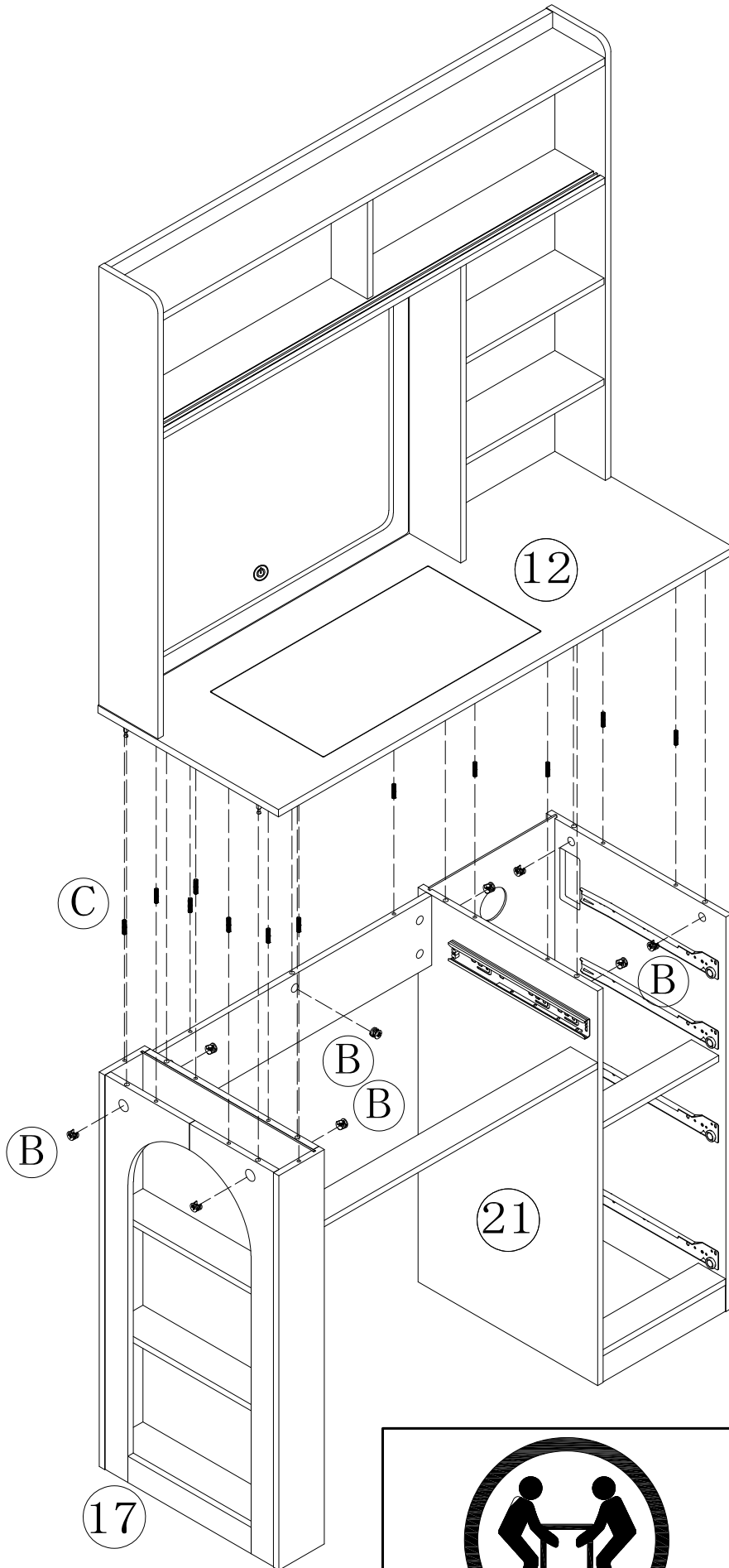

# Step 29



**CAUTION:** Heavy! You may need assistance with this step.

- B  9PCS  
Ø15\*9.5
- C  12PCS  
Ø6\*30

# Step 30

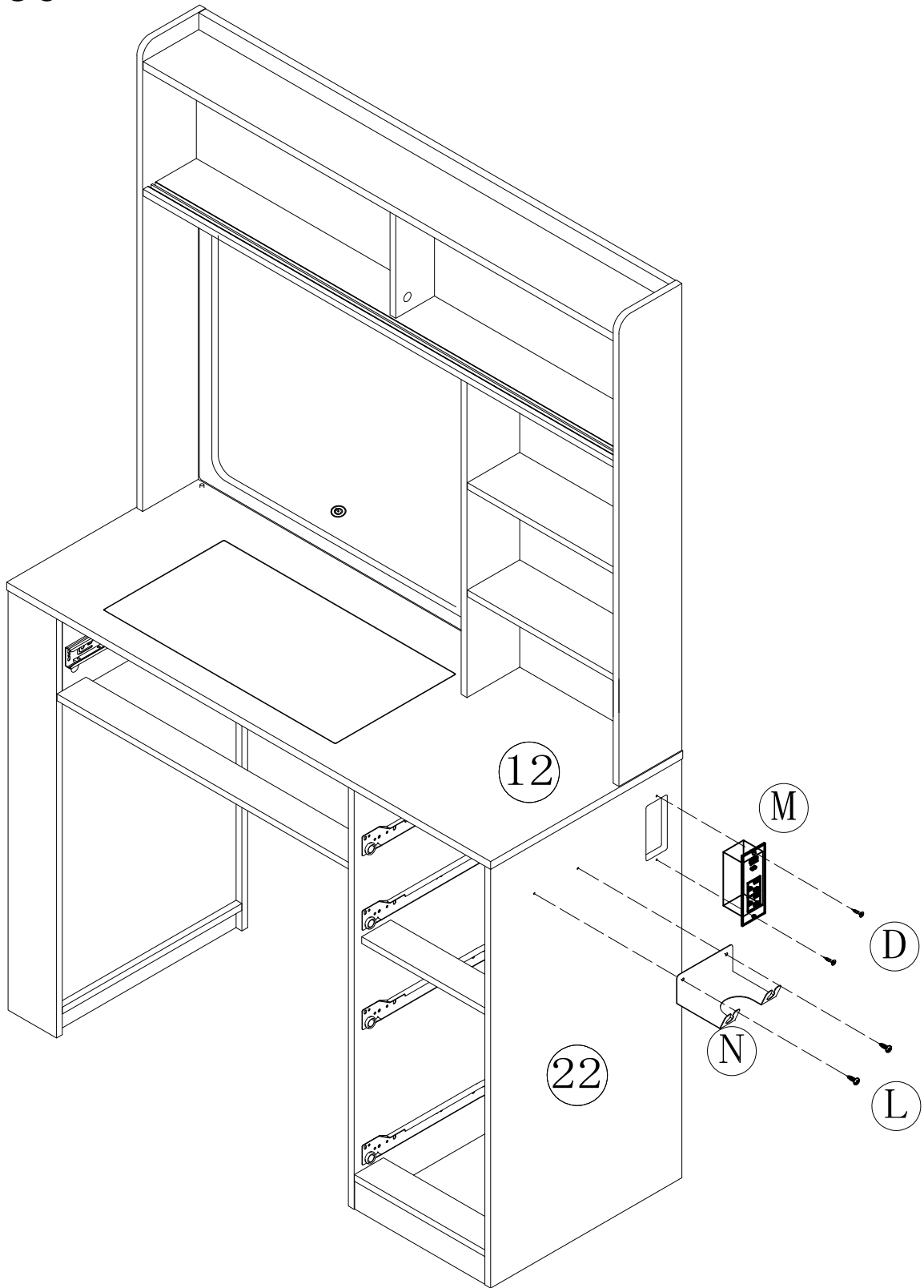

(M)  1PCS



(D)  2PCS  
Ø3\*12

(N)  1PCS  
105\*115\*1.0mm

(L)  2PCS  
Ø3\*12

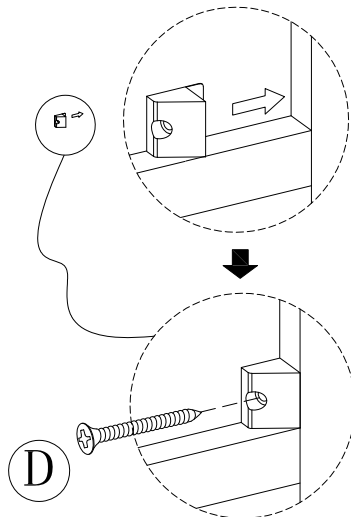
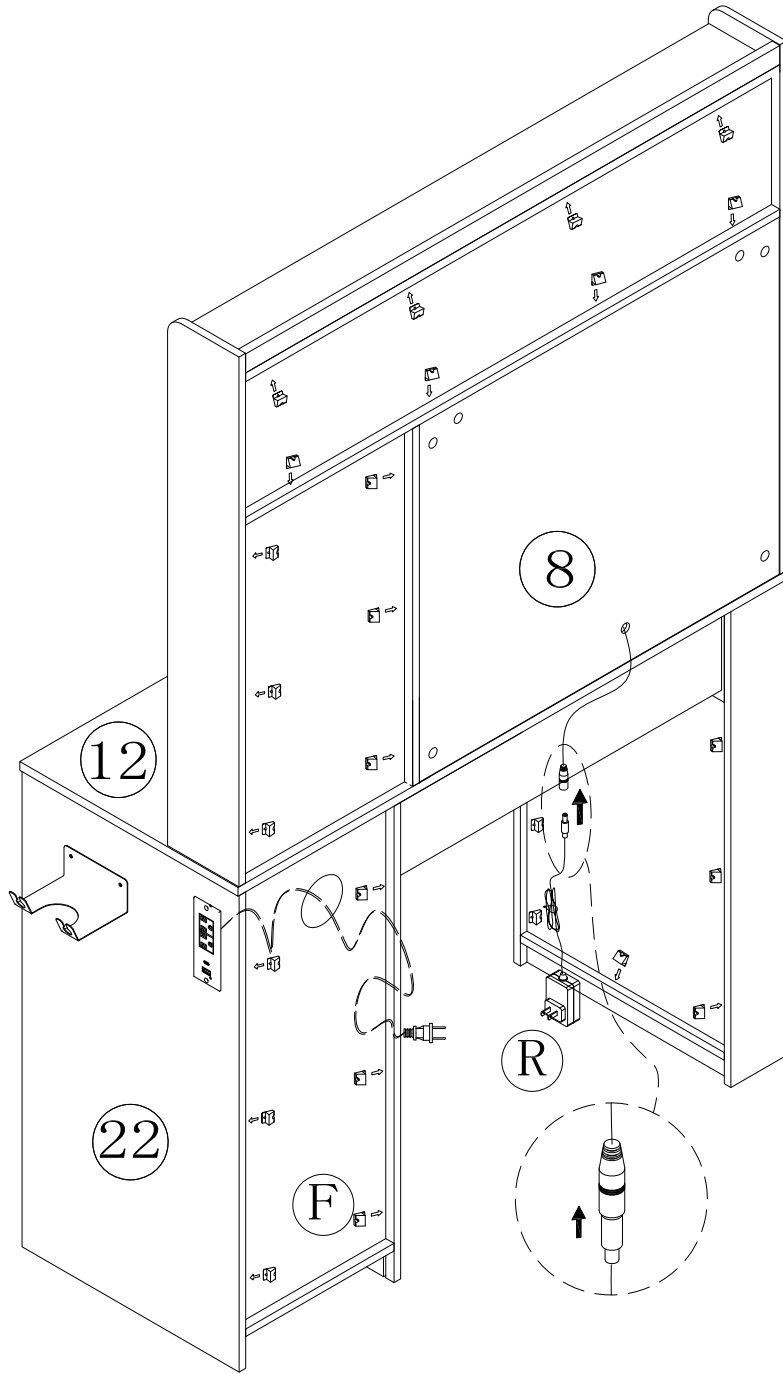
# Step 31



- (D)  27PCS  
Ø3\*12
- (F)  27PCS
- (R) 

# Step 32

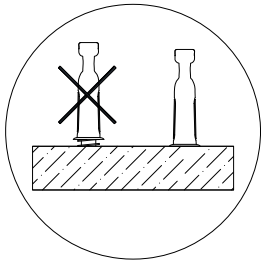
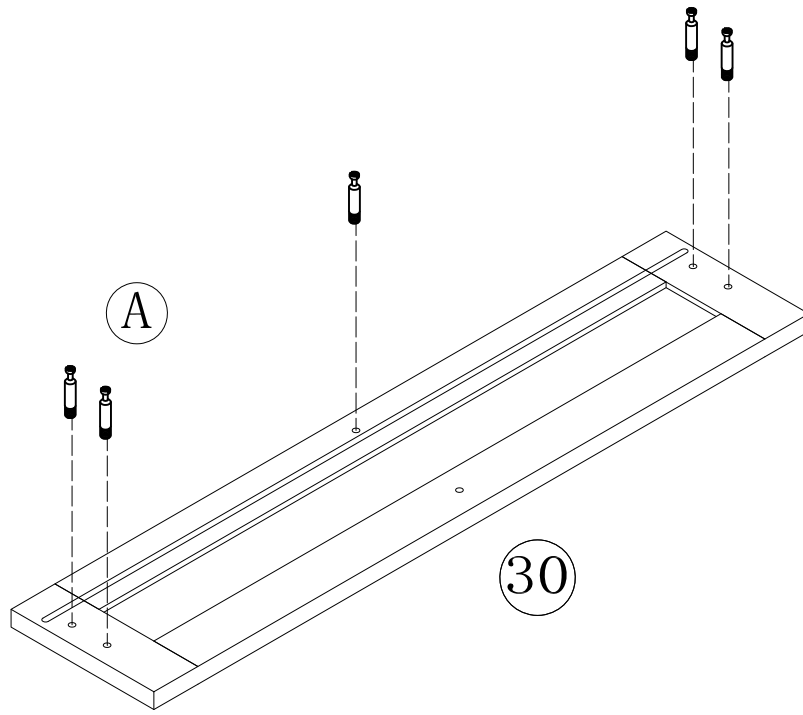

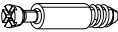
(A)  5PCS  
Ø6\*35

# Step 33

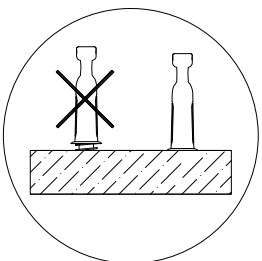
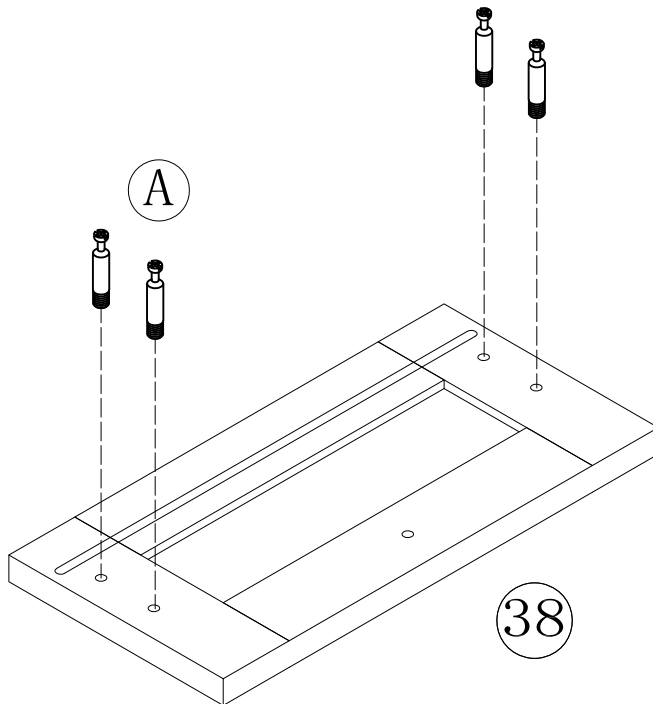

X2

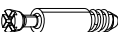
(A)  8PCS  
Ø6\*35

# Step 34

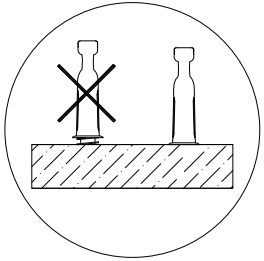
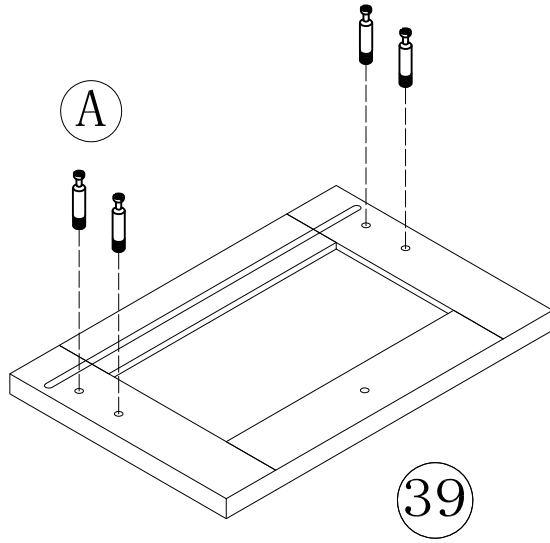

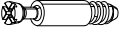
Ⓐ  4PCS  
Ø6\*35

# Step 35

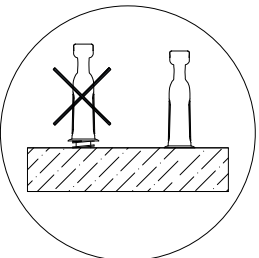
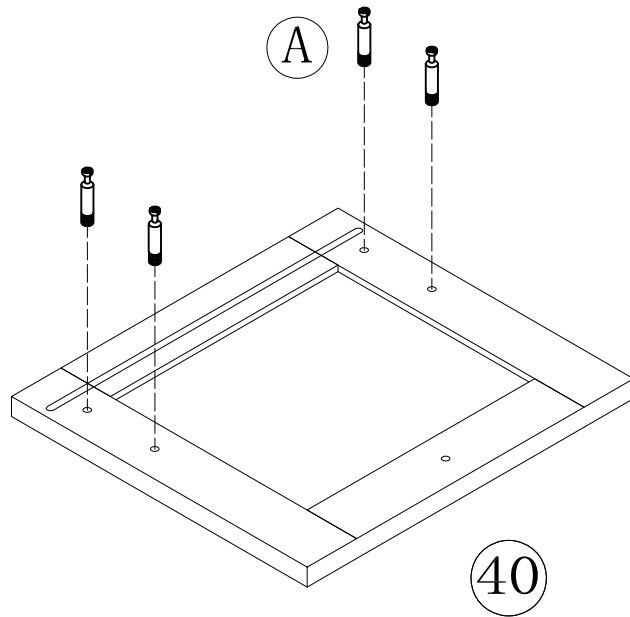

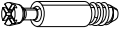
Ⓐ  4PCS  
Ø6\*35

# Step 36

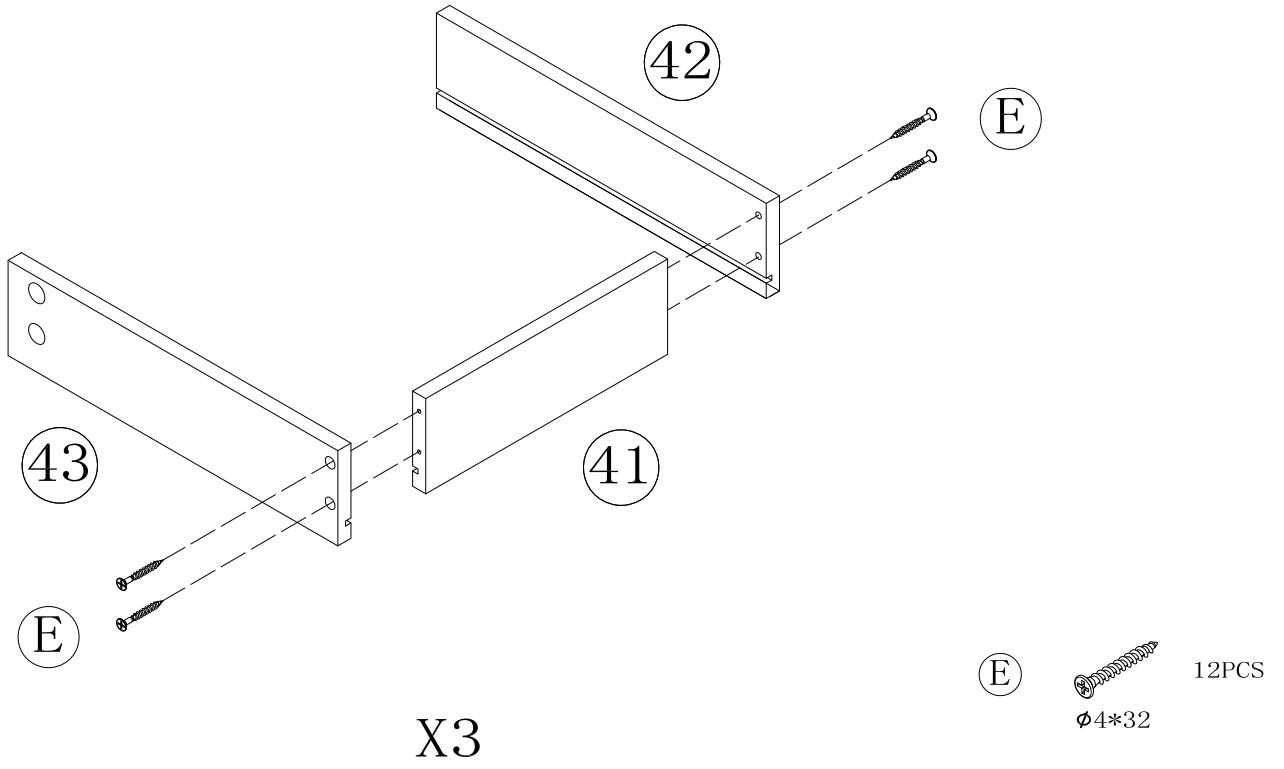

# Step 37

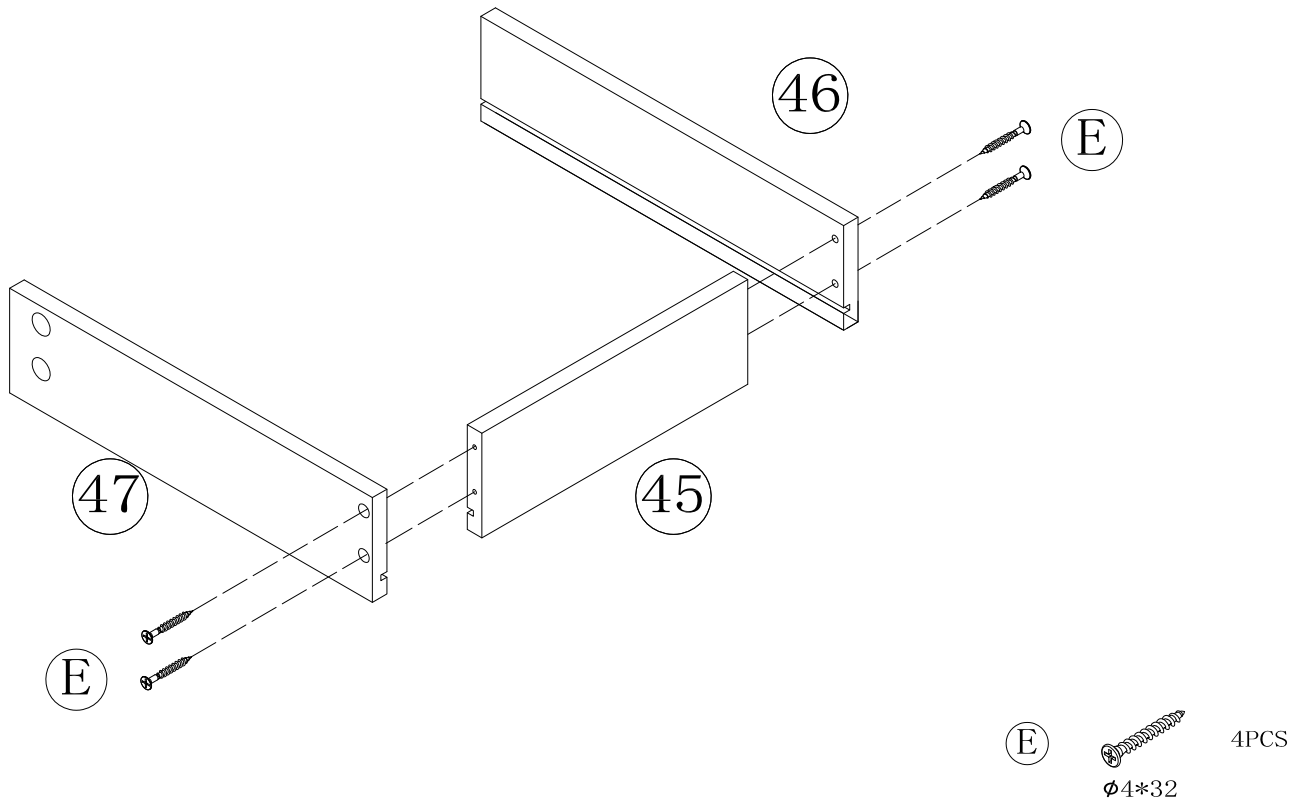

# Step 38

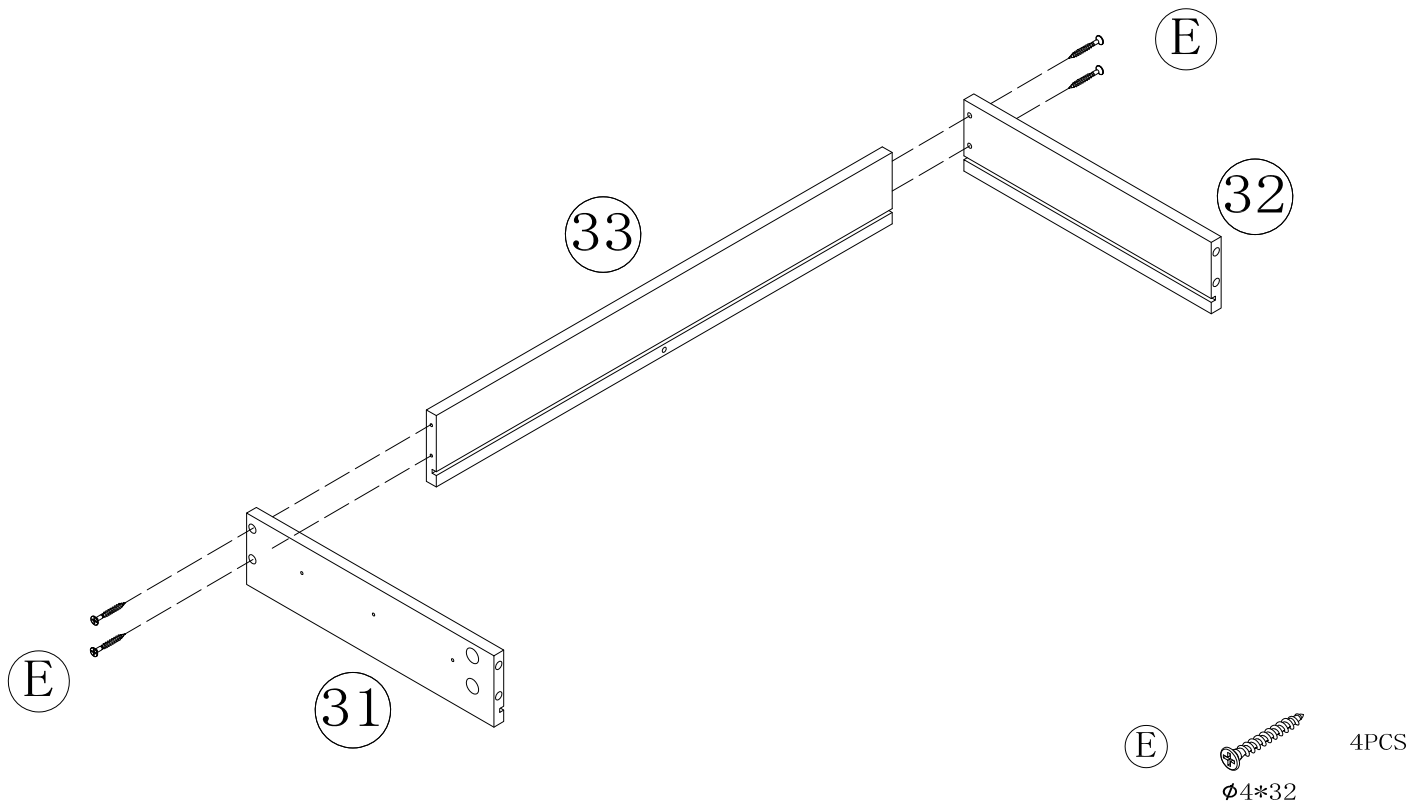

# Step 39

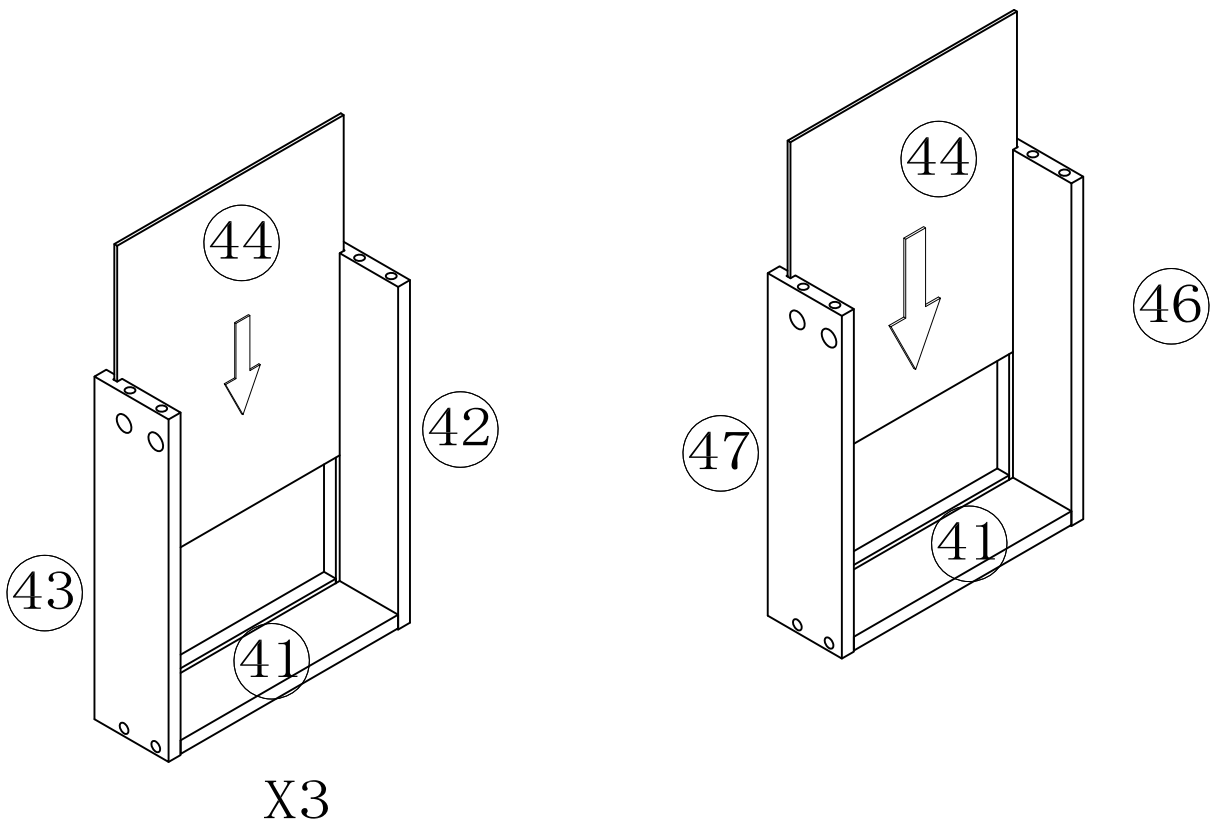

# Step 40

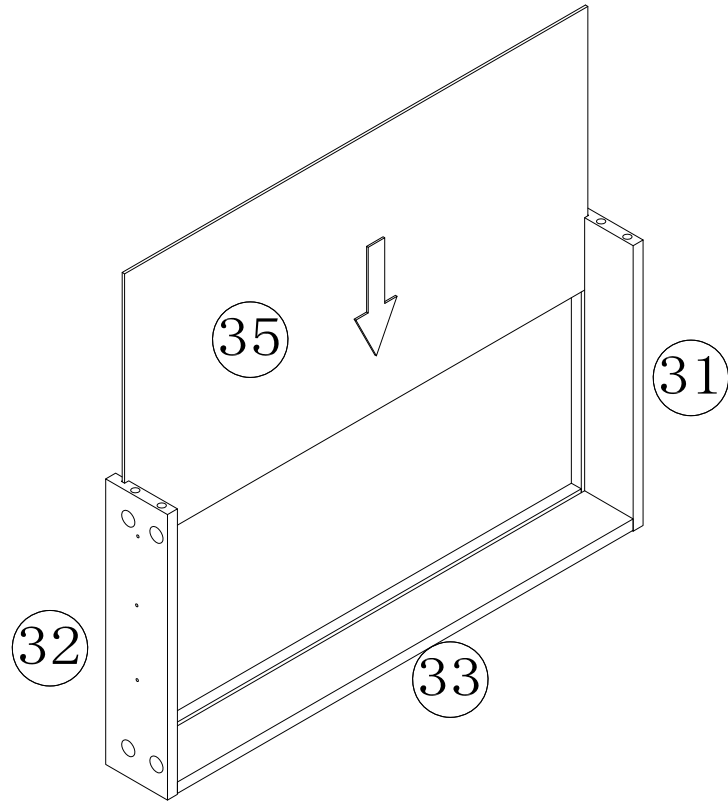

# Step 41

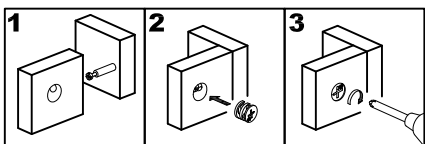
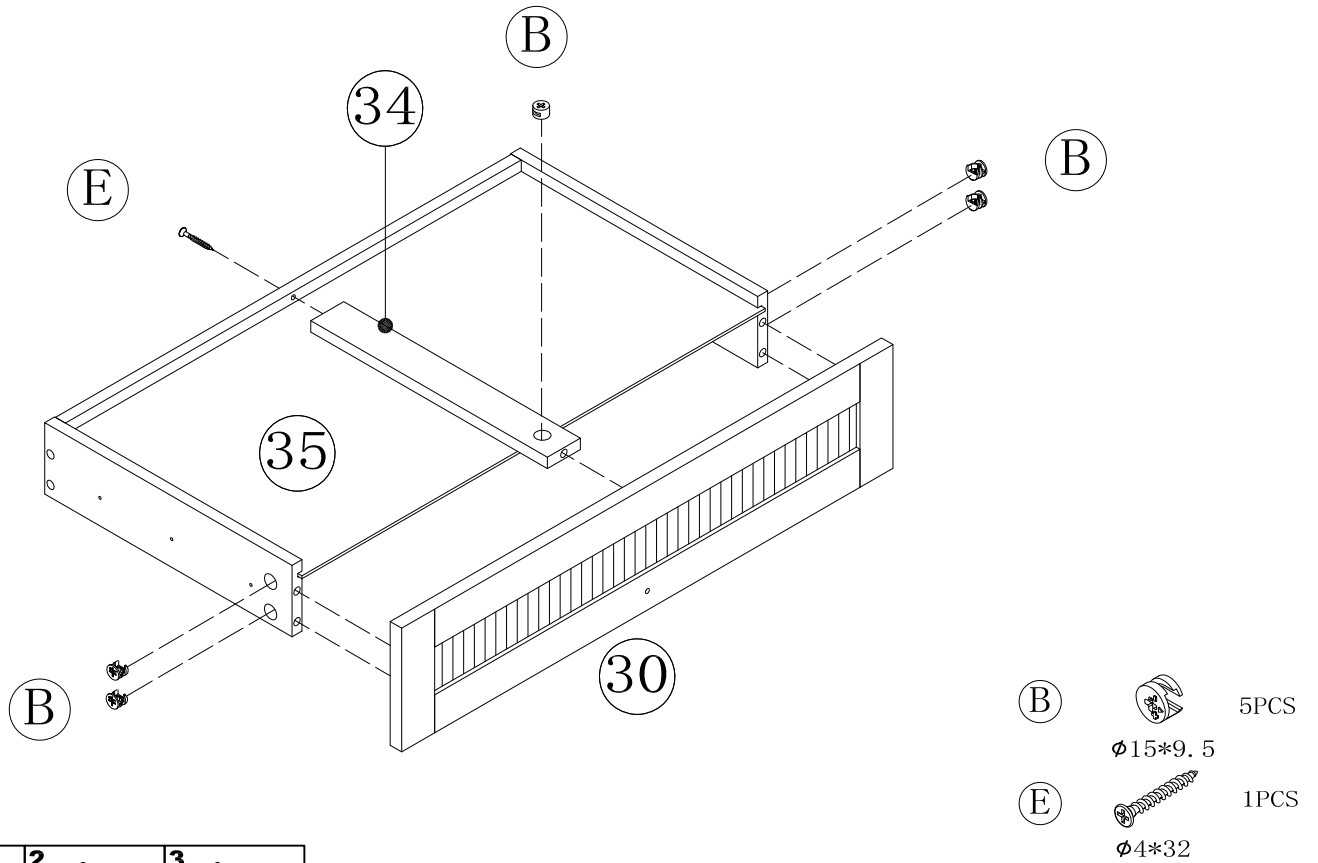

# Step 42

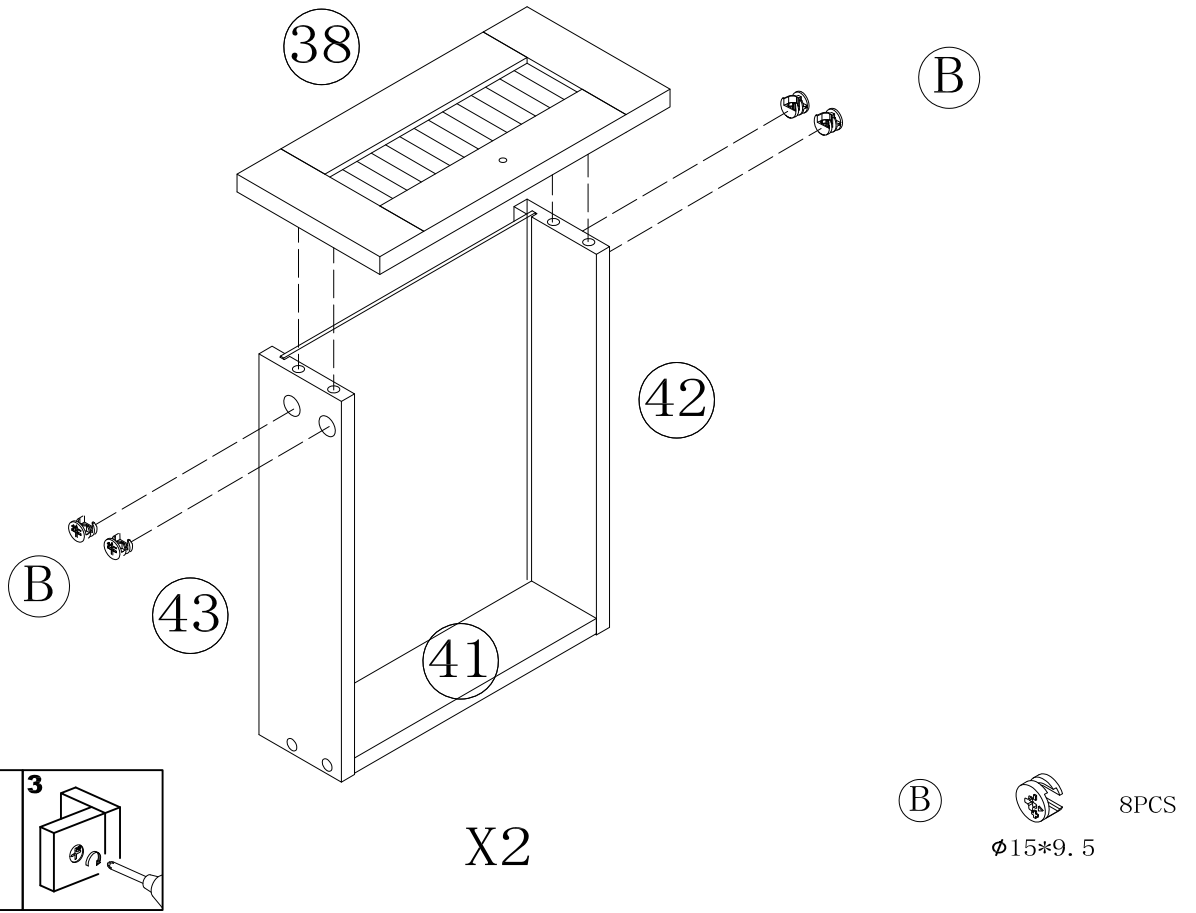

# Step 43

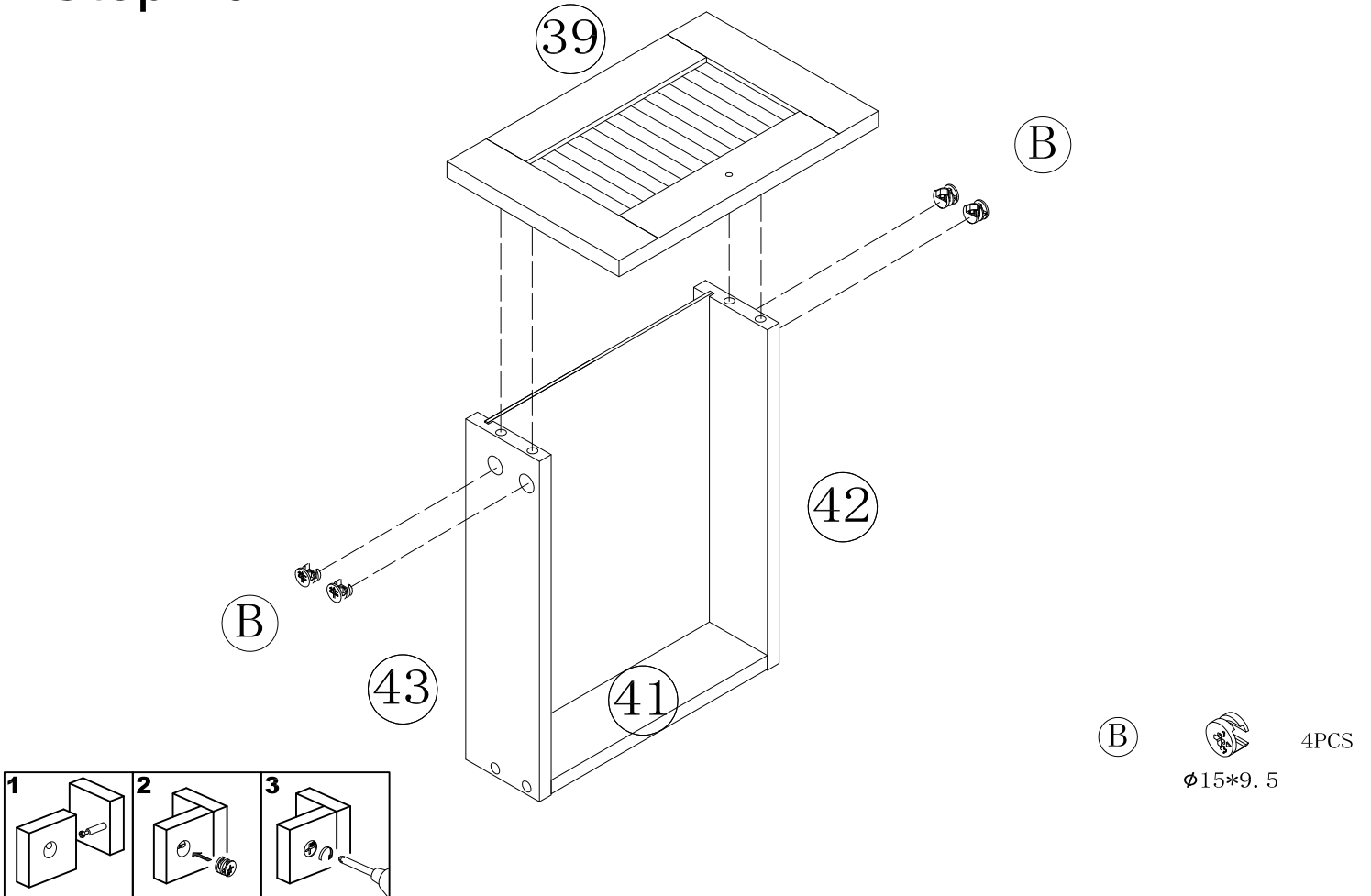

# Step 44

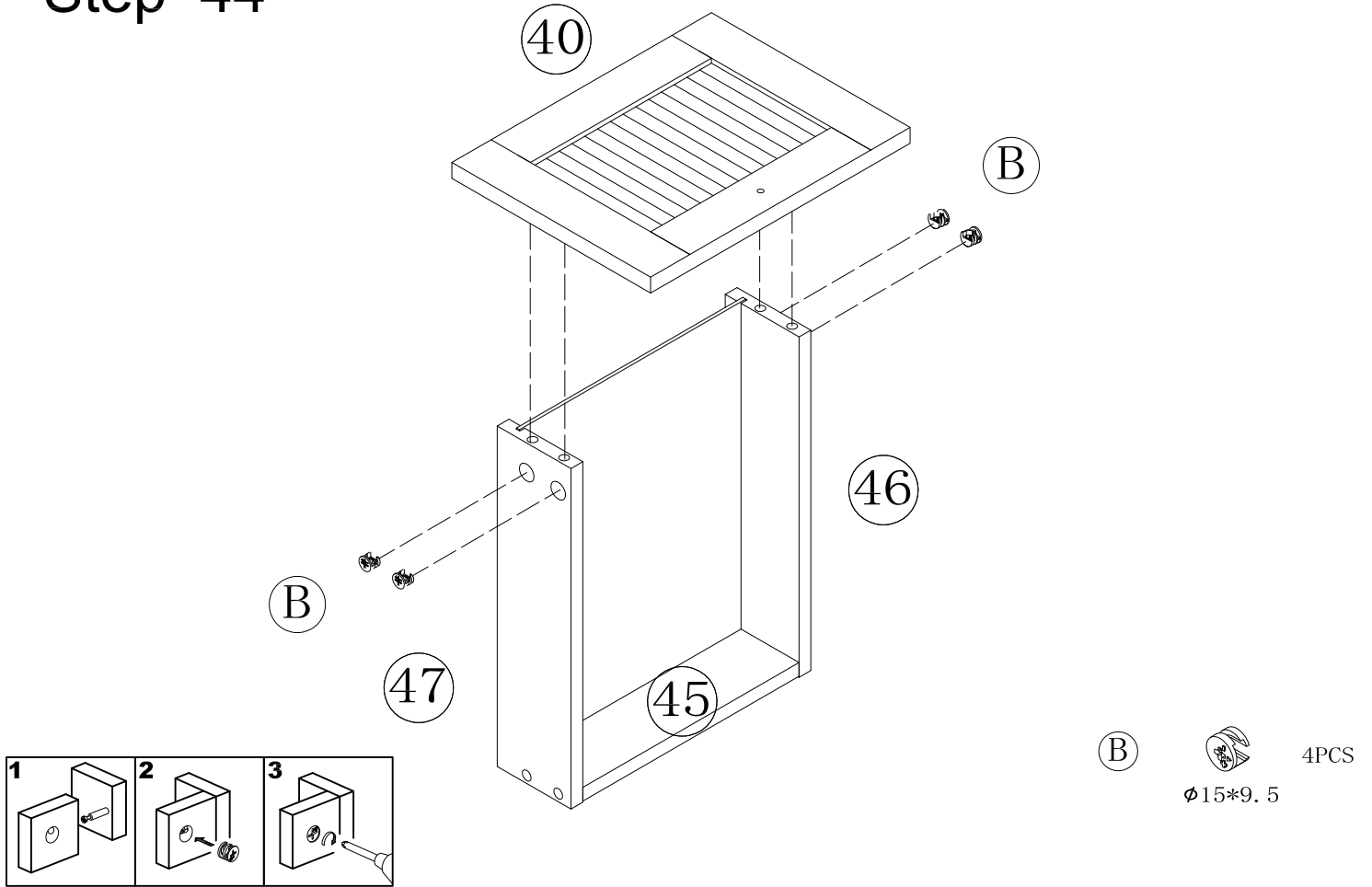

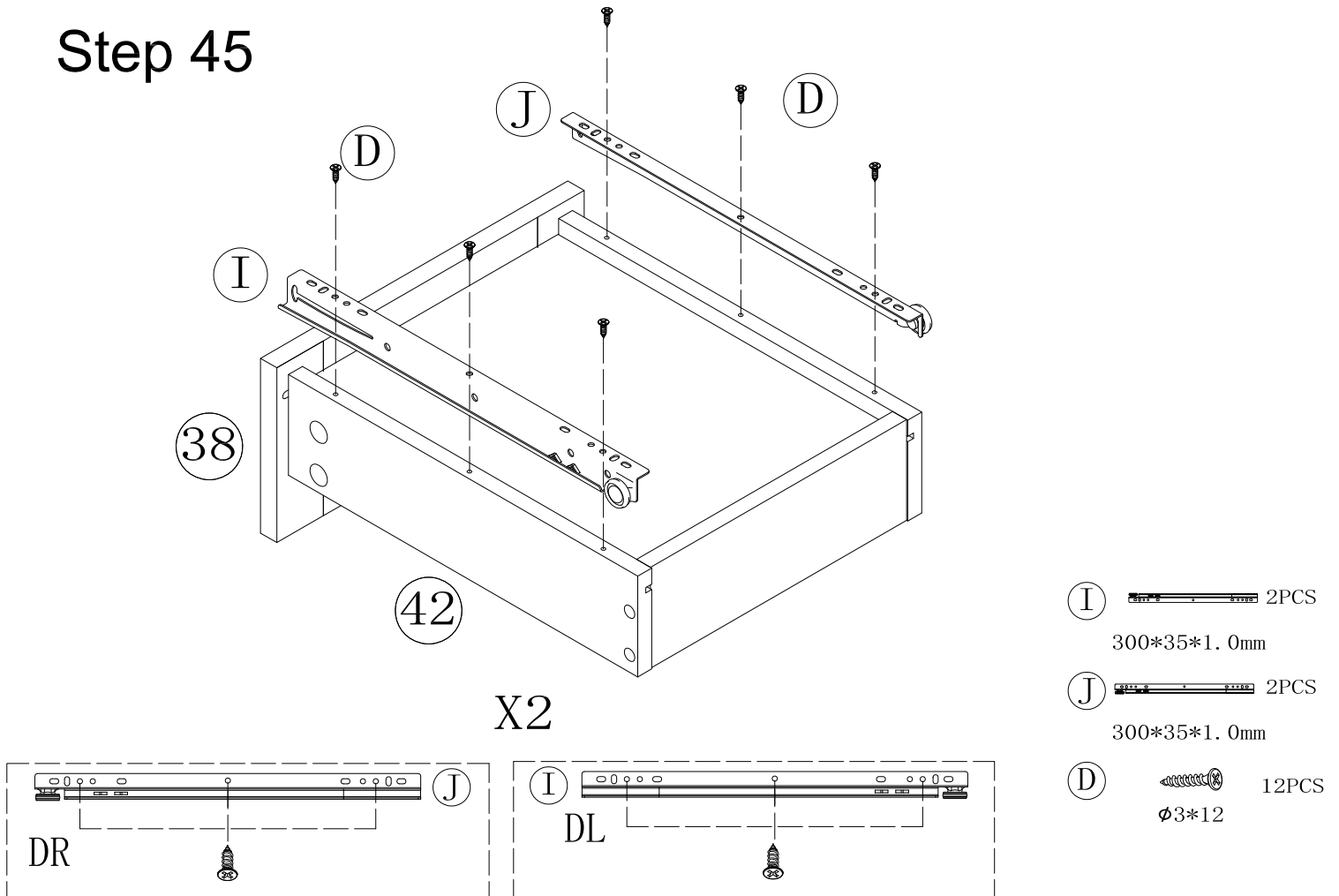

# Step 45



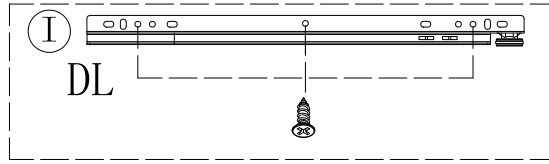
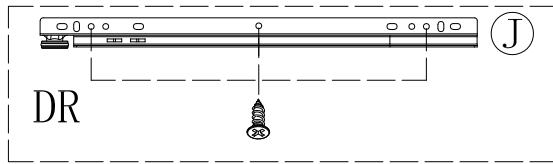
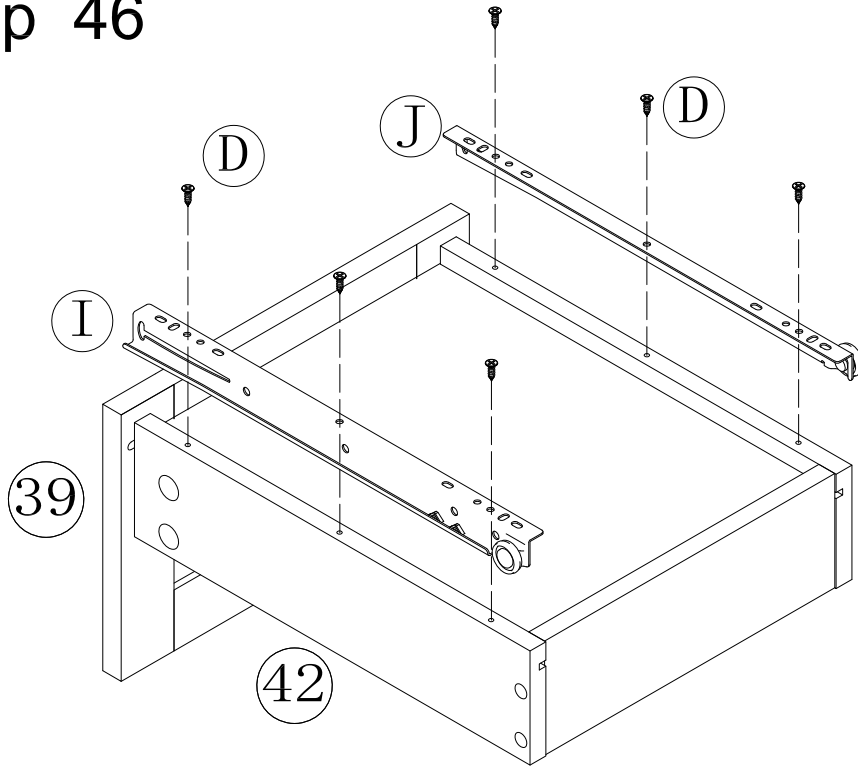

# Step 46

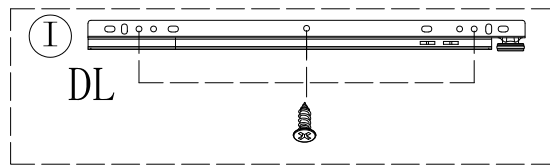
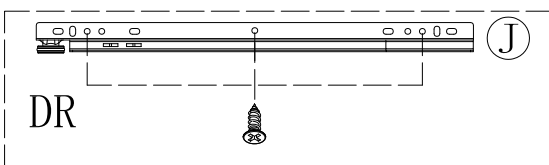
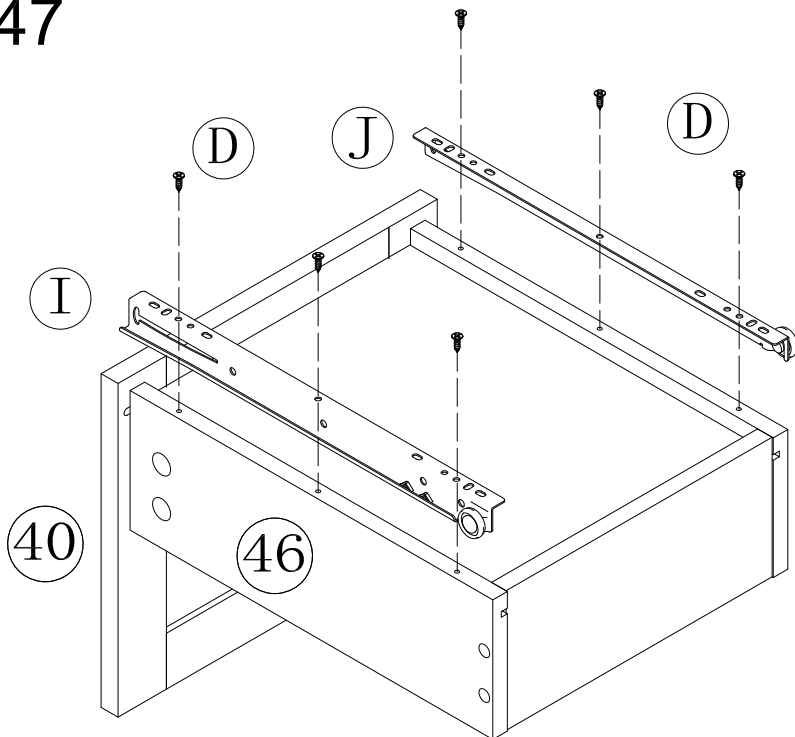

- ①  1PCS  
300\*35\*1.0mm
- ②  1PCS  
300\*35\*1.0mm
- ③  6PCS  
Ø3\*12

# Step 47

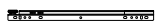

- ①  1PCS  
300\*35\*1.0mm
- ②  1PCS  
300\*35\*1.0mm
- ③  6PCS  
Ø3\*12

# Step 48

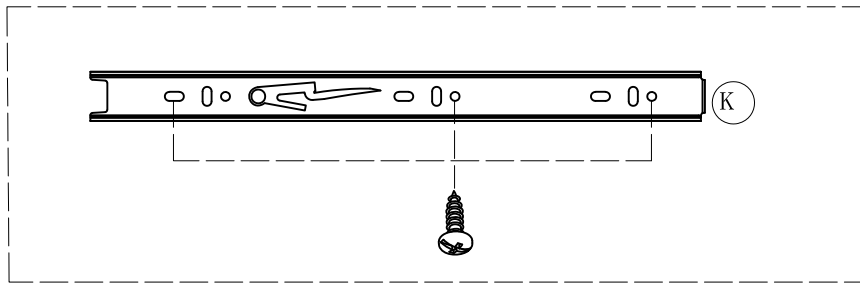
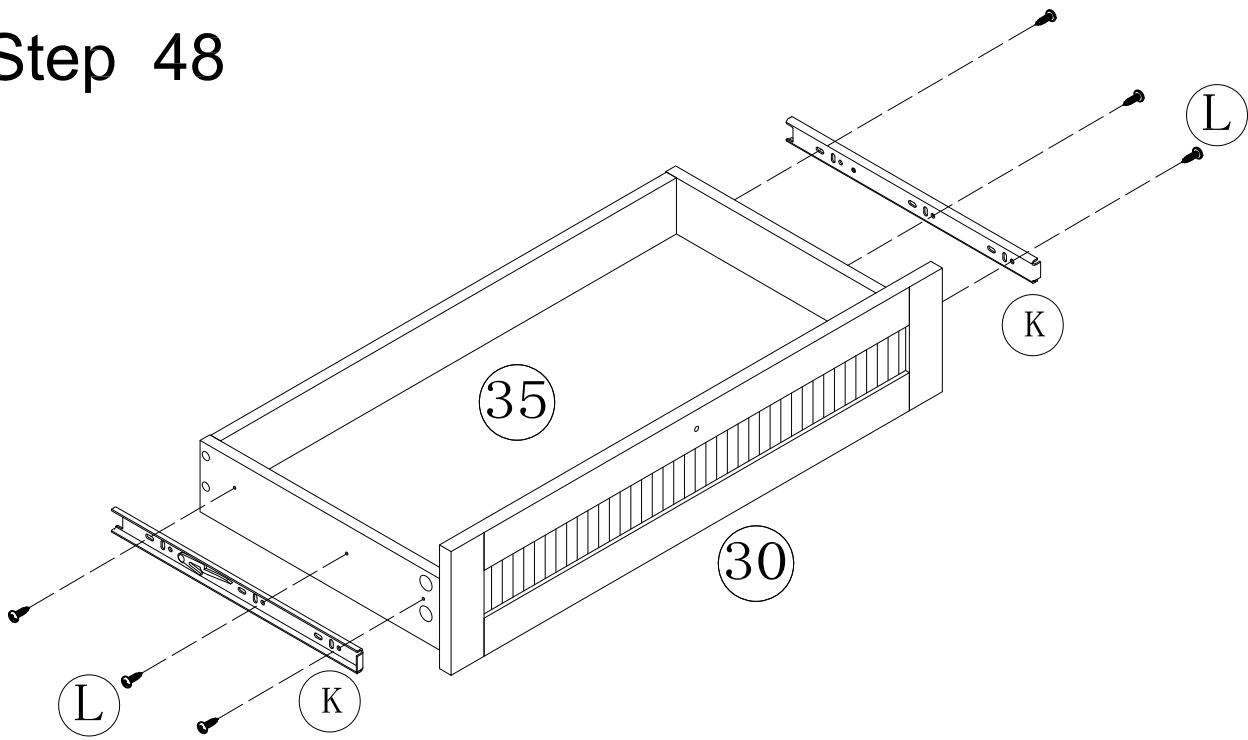

- L
 6PCS  
 $\phi 3 \times 12$
- K
 2PCS  
 $300 \times 35 \times 1.0$

# Step 49

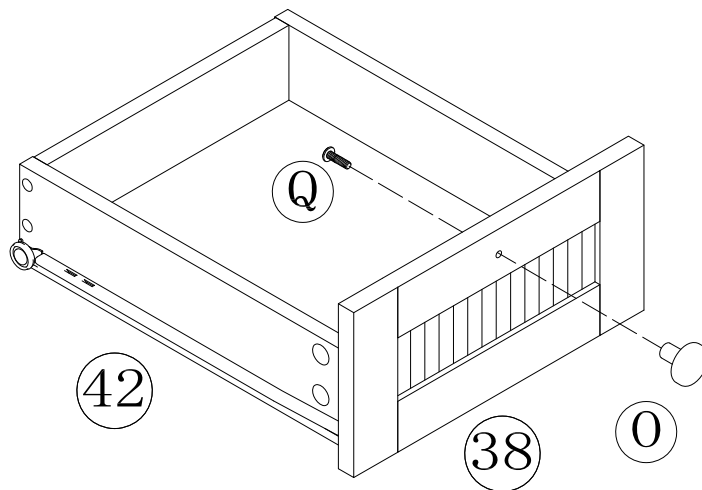

X2

- O
 2PCS
- Q
 2PCS  
 $\phi 4 \times 18 \text{mm}$

# Step 50

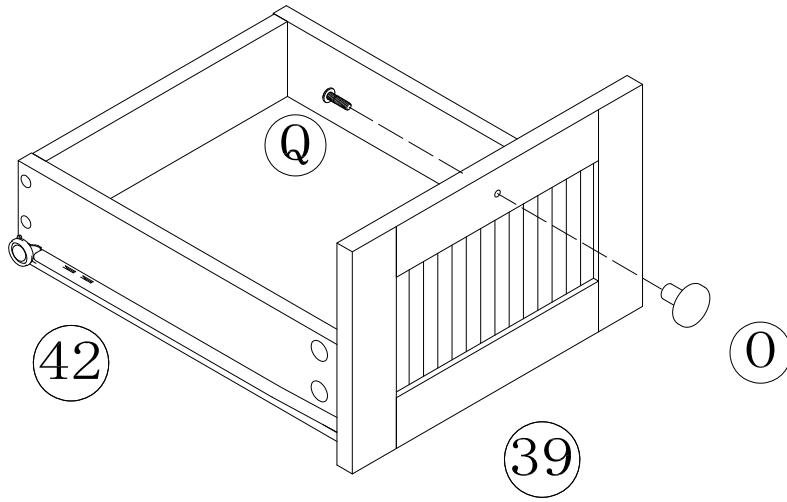

○ 0 1PCS

○ Q 1PCS  
Ø4\*18mm

# Step 51

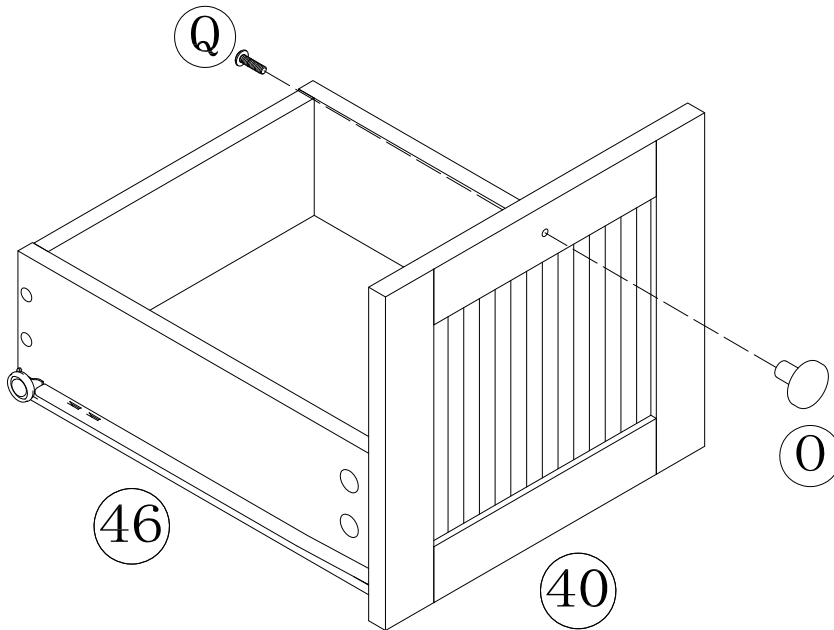

○ 0 1PCS

○ Q 1PCS  
Ø4\*18mm

# Step 52

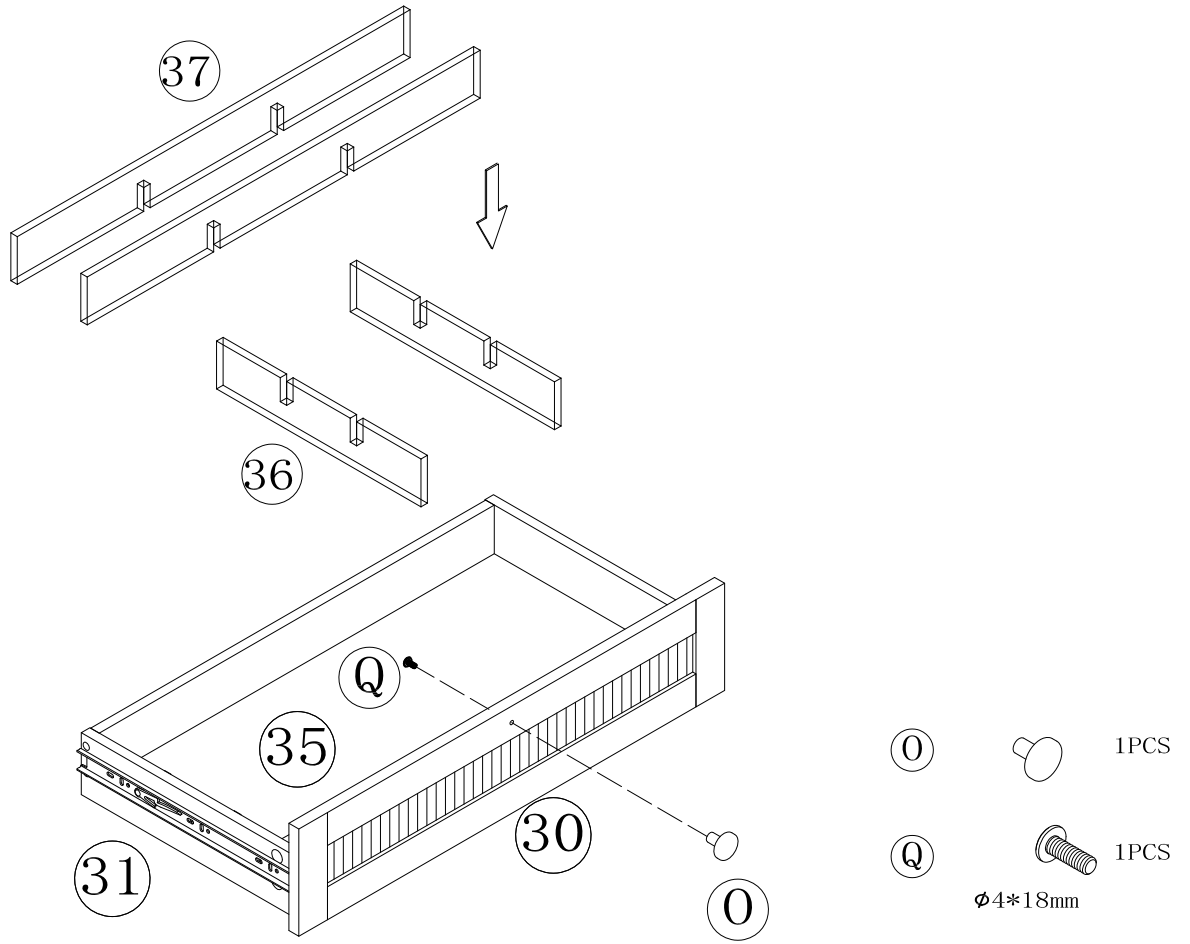

# Step 53

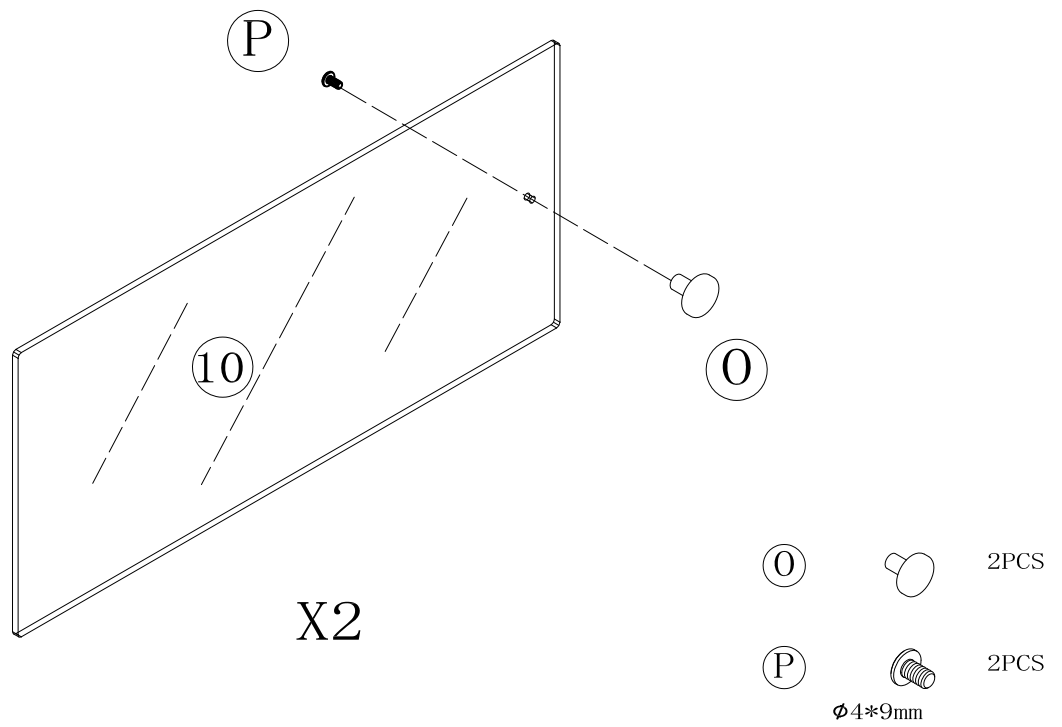

# Step 54

When installing the glass, first place the top of the glass into the top groove as shown in the diagram, and then place the bottom of the glass into the bottom groove. The top and bottom grooves of the glass should be vertically aligned.

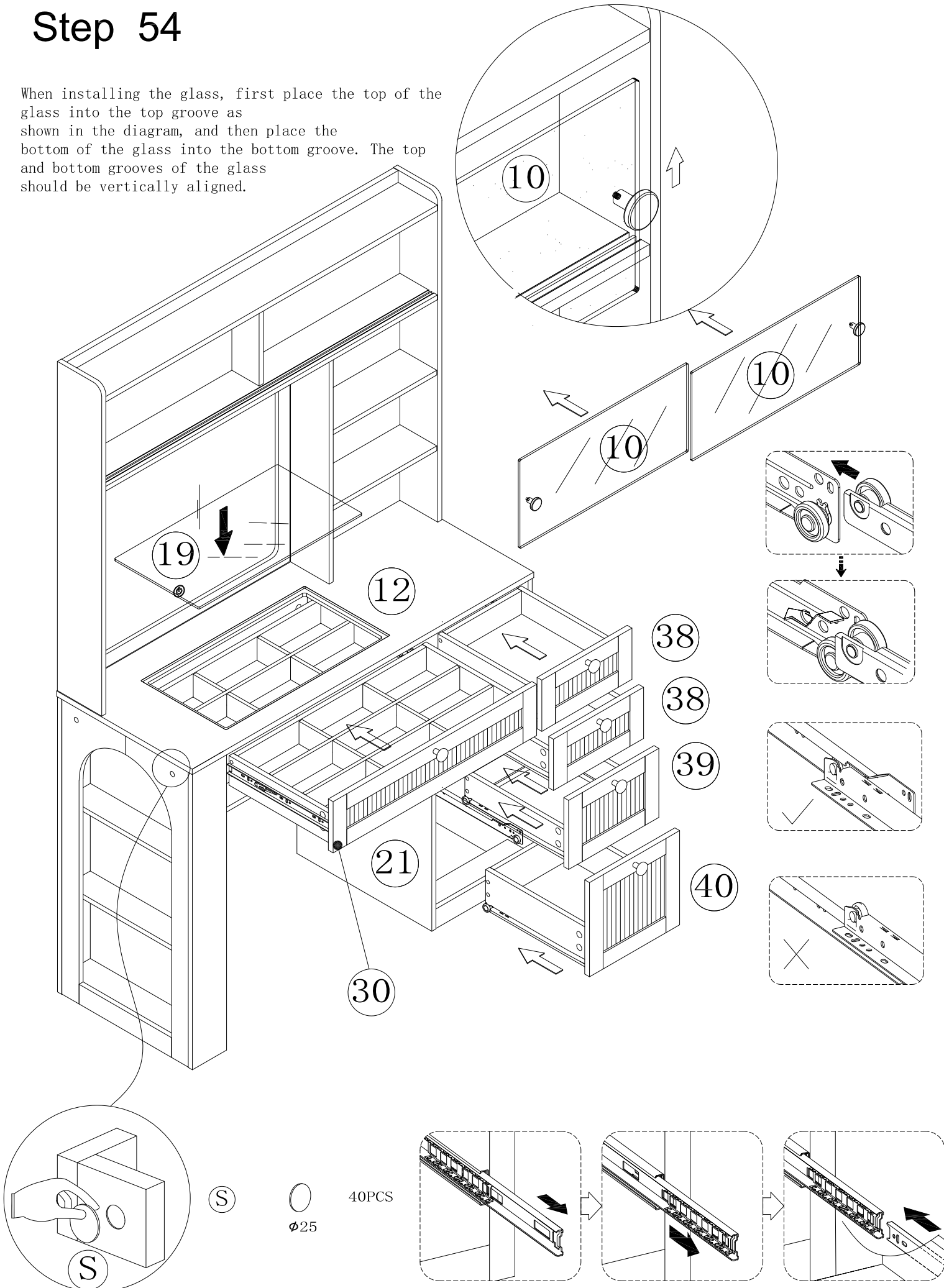

# Step 55

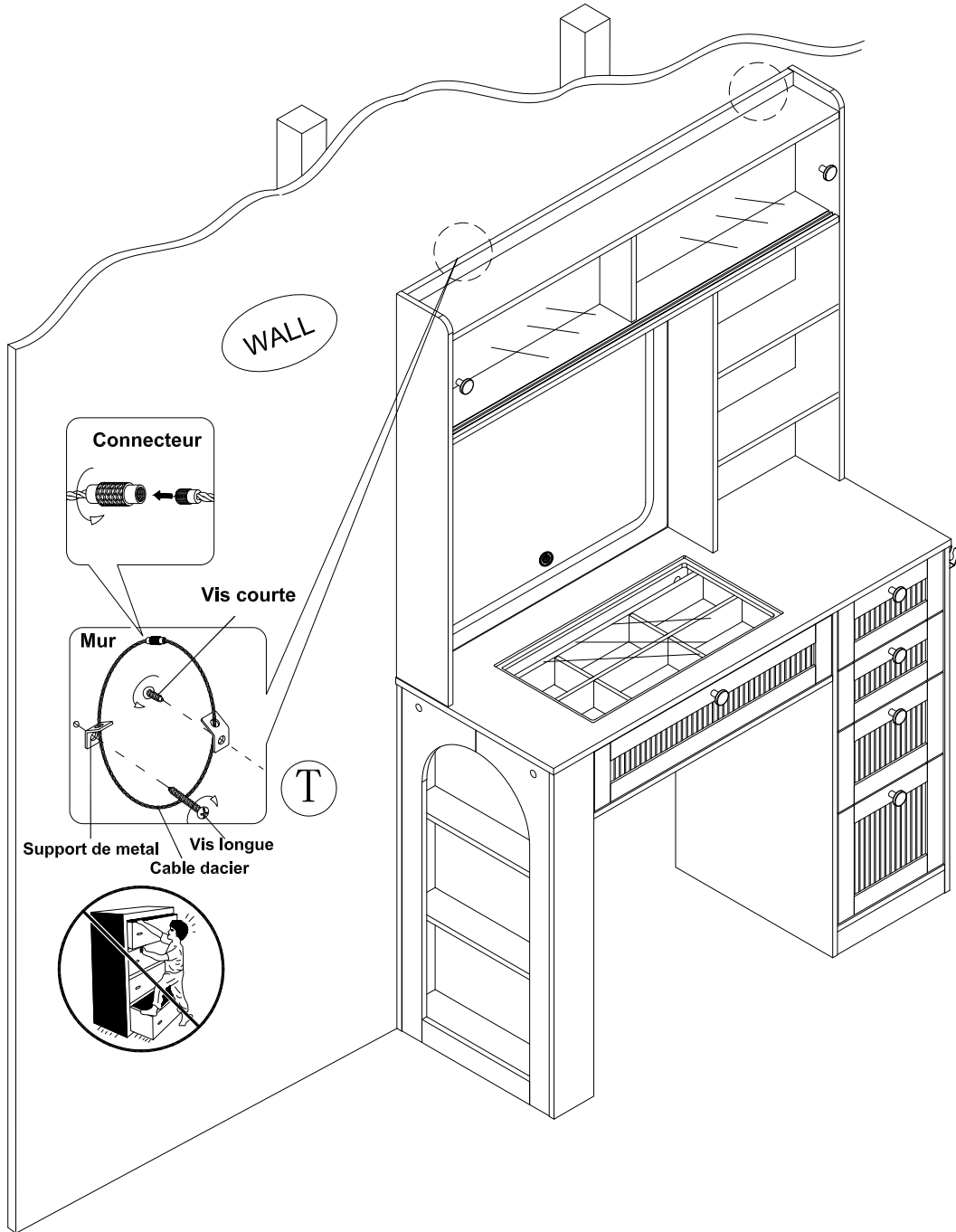

Final Assembly

# IRONCK

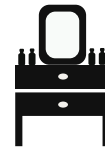

Please don't tighten the screws completely and go back later for a final tightening of all the screws after pieces are aligned with each other