

Montageanleitung | Instructions de montage Assembly Instructions | Instrucciones de montaje

SKU NUMBER:N701P174767+N701P174881+N701P174886

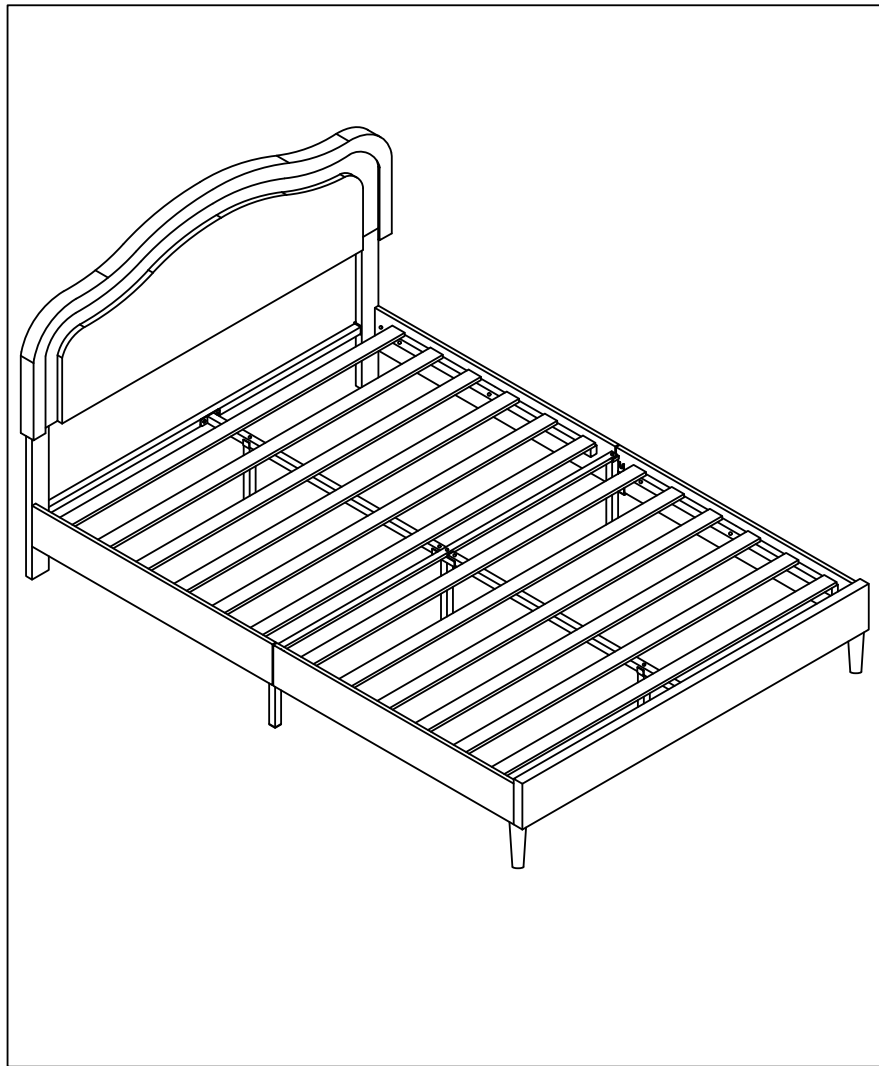

1 /20

English

IMPORTANT ! KEEP FOR FUTURE REFERENCE : READ CAREFULLY

- To be assembled by an adult. Assembly must be checked by an adult before use
- WARNING ! Keep all screws, small parts and plastic bags out of the reach of children
- Properly identify all parts before assembling
- Never use your item if any of its parts are broken or missing
- Should any problems arise, please contact our After Sales Service
- Manufacturer's instructions shall be followed at all times
- Care: Clean with a soft, dry cloth. In case of larger stains, carefully rub with a slightly damp, non-abrasive sponge
- Do not jump on the bed

Français

IMPORTANT ! CONSERVER POUR RÉFÉRENCE ULTÉRIEURE : LIRE ATTENTIVEMENT

- Le montage doit être effectué par un adulte. Le montage doit être vérifié par un adulte avant utilisation
- ATTENTION ! Tenir les vis, les petites pièces et les sachets en plastique hors de portée des enfants
- Identifiez correctement toutes les pièces avant de les assembler
- N'utilisez jamais votre article si l'une de ses pièces est cassée ou manquante
- En cas de problème, veuillez contacter notre service après-vente
- Les instructions du fabricant doivent être respectées à tout moment
- Entretien : nettoyer avec un chiffon doux et sec. En cas de taches plus importantes, frotter soigneusement avec une éponge non abrasive légèrement humide. légèrement humide et non abrasive
- Ne pas sauter sur le lit

Deutsch

WICHTIG ! ZUM SPÄTEREN NACHSCHLAGEN AUFBEWAHREN: SORGFÄLTIG LESEN

- Muss von einem Erwachsenen zusammengebaut werden. Der Zusammenbau muss vor dem Gebrauch von einem Erwachsenen überprüft werden
- WARNUNG! Bewahren Sie alle Schrauben, Kleinteile und Plastikbeutel außerhalb der Reichweite von Kindern auf
- Kennzeichnen Sie vor dem Zusammenbau alle Teile richtig.
- Benutzen Sie Ihren Artikel niemals, wenn Teile gebrochen sind oder fehlen
- Sollten Probleme auftreten, wenden Sie sich bitte an unseren Kundendienst
- Die Anweisungen des Herstellers sind stets zu befolgen
- Pflege: Mit einem weichen, trockenen Tuch reinigen. Bei größeren Flecken vorsichtig mit einem leicht feuchten, nicht scheuernden Schwamm abreiben. nicht scheuernden Schwamm
- Nicht auf das Bett springen

2 /20

💡 More Tips 💡

1

English - Before installation, you can place the parts on a carpet or other soft fabric, in order to avoid damaging your floor.

Français - Avant l'installation, vous pouvez placer les pièces sur un tapis ou un autre tissu doux, afin d'éviter d'endommager votre sol.

Deutsch - Vor der Installation können Sie die Teile auf einen Teppich oder ein anderes weiches Material legen, um eine Beschädigung Ihres Fußbodens zu vermeiden.

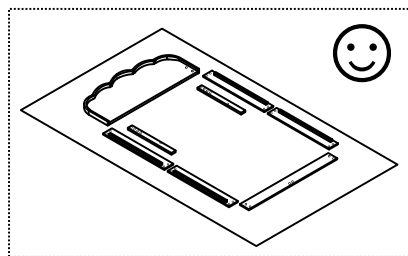
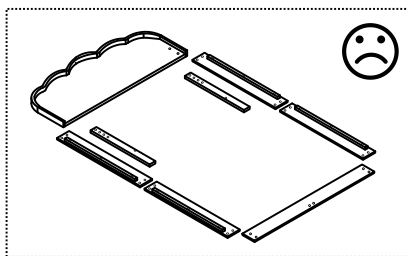

2

English - For your and your family's safety, please do not jump on beds, especially with hydraulic structures. When need to move bed, please work with more than one person to lift, not push, to avoid scratching your floor and hurting the stability of the bed.

Français - Pour votre sécurité et celle de votre famille, ne sautez pas sur les lits, en particulier sur les structures hydrauliques. Lorsqu'il est nécessaire de déplacer le lit, il est préférable de travailler à plusieurs pour le soulever, et non pour le pousser, afin d'éviter de rayer le sol et de nuire à la stabilité du lit.

Deutsch - Zu Ihrer Sicherheit und der Ihrer Familie sollten Sie nicht auf Betten springen, insbesondere bei hydraulischen Konstruktionen. Wenn Sie das Bett bewegen müssen, heben Sie es bitte mit mehreren Personen an und schieben Sie es nicht, um den Boden nicht zu verkratzen und die Stabilität des Bettes nicht zu beeinträchtigen.

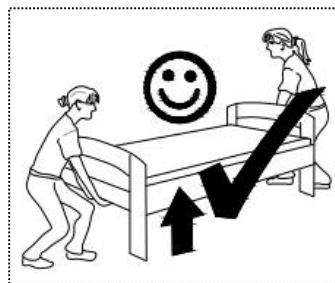



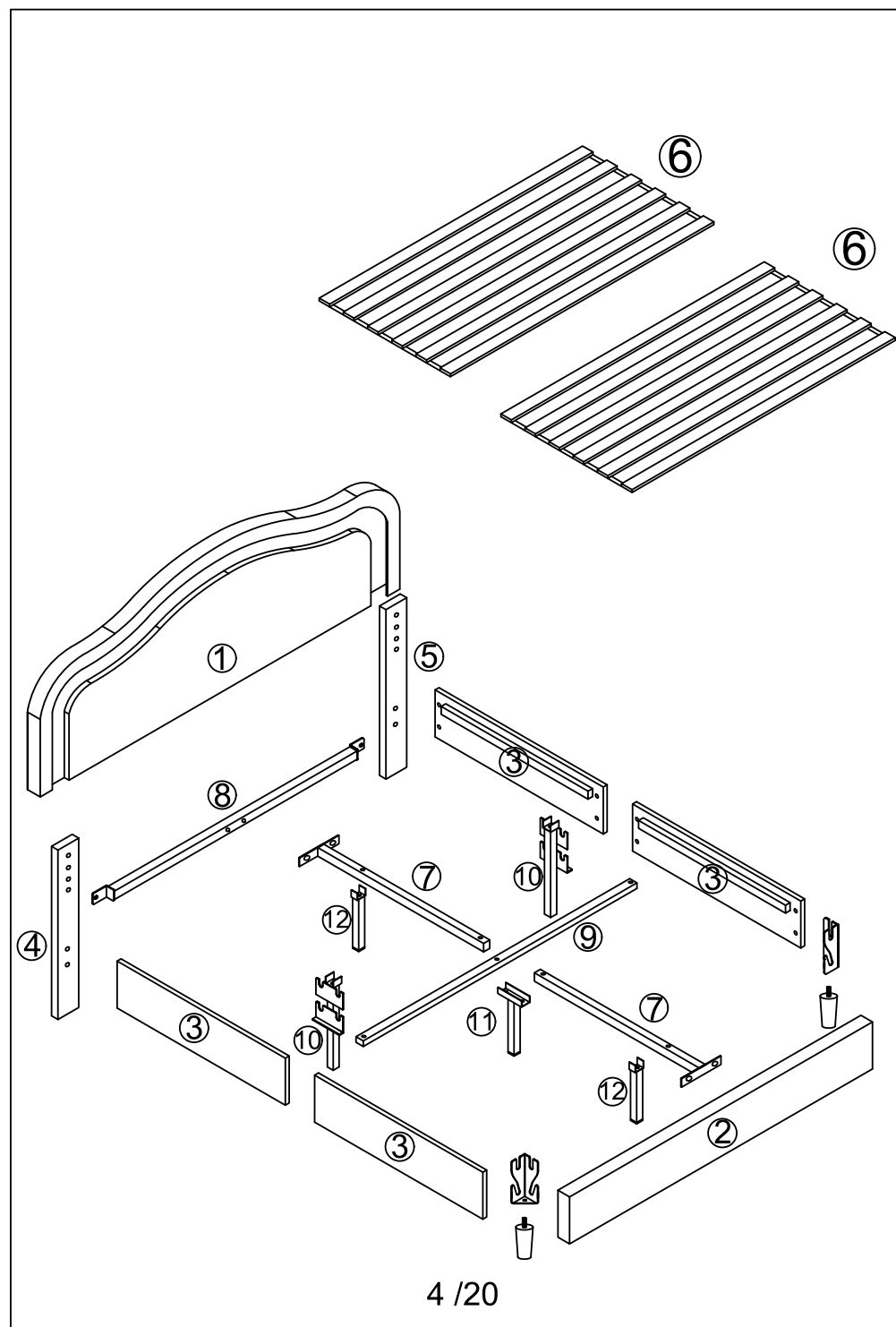







3 / 20





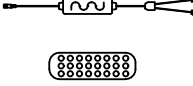
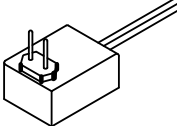

4 / 20

Hardware List-Hardware-Liste-Liste du matériel

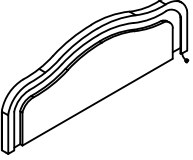
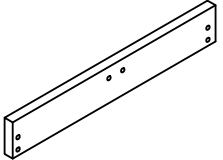
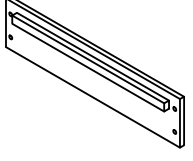
(A)	 M8 x 18	16	(B)	 M8 x 25	16
(C)	 M8 x 45	9	(D)		4
(E)	 M5	1	(F)		2
(G)	 Angle iron (Left)	1	(H)	 Angle iron (Right)	1
(I)		2	(J)	 Strip light	1
(K)	 Infrared receiver	1	(L)		1

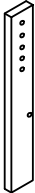
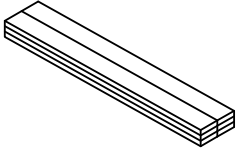
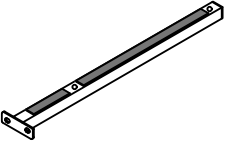
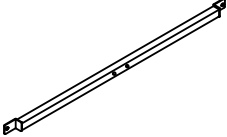
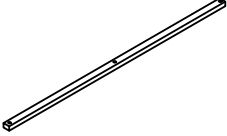
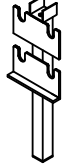
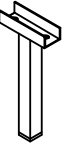
6 / 20

(1)		1pc	(2)		1pc
(3)		4pcs	(4)		1pc
(5)		1pc	(6)		2sets
(7)		2pcs	(8)		1pc
(9)		1pc	(10)		2pcs
(11)		1pc	(12)		2pcs

5 / 20

1

- M8*25 B*2PCS
- M8*45 C*4PCS
- D*4PCS
- E*1PC

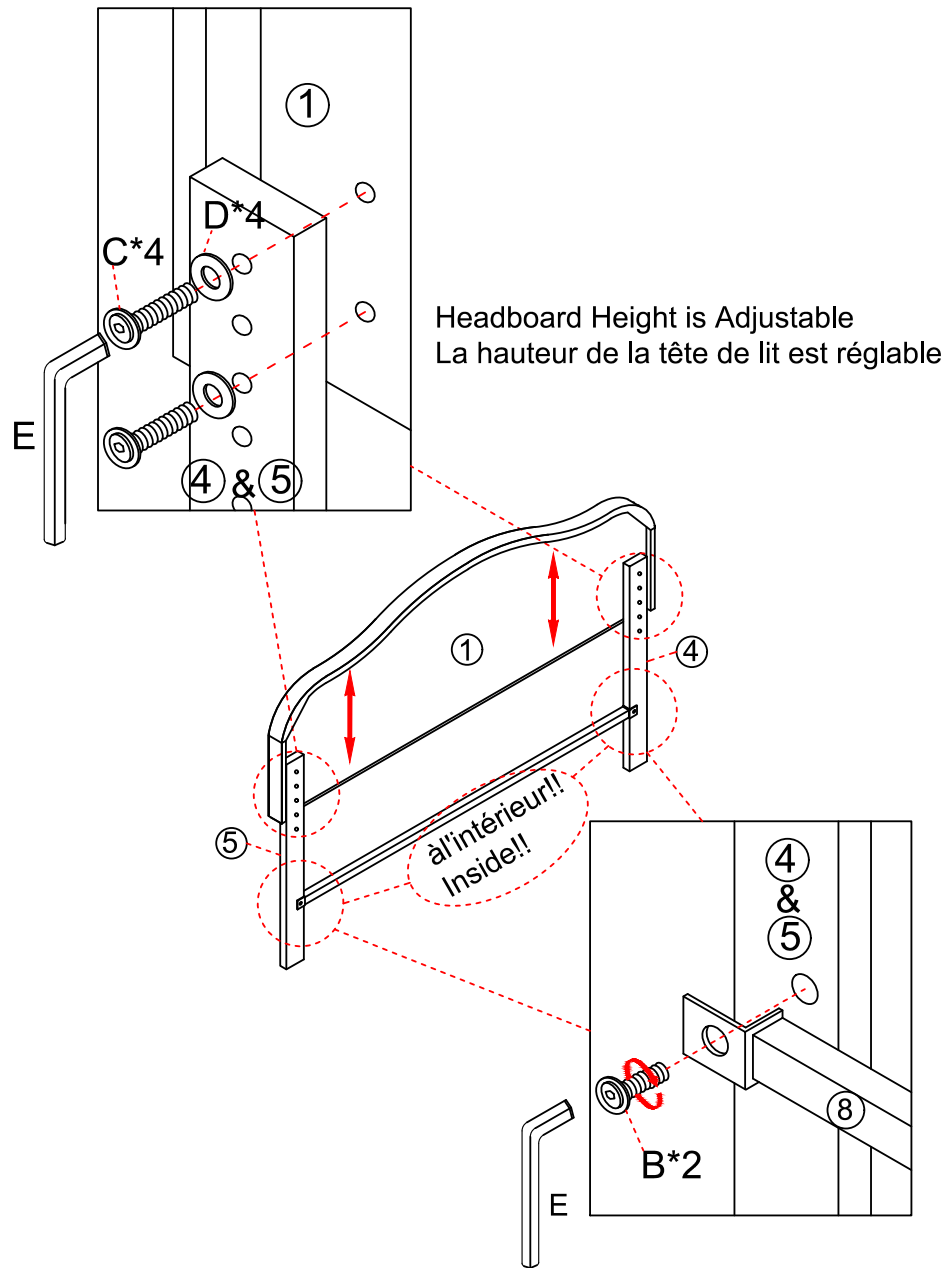

7 / 20

2

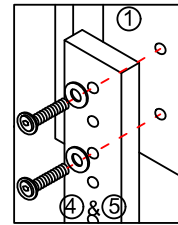

Use these holes to fit a 10 inch thick mattress
Utilisez ces trous pour s'adapter à un matelas de 10 pouces d'épaisseur

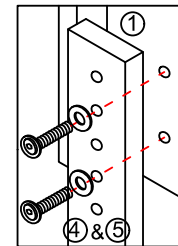

Use these holes to fit a 8 inch thick mattress
Utilisez ces trous pour s'adapter à un matelas de 8 pouces d'épaisseur

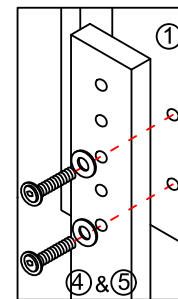

Use these holes to fit a 6 inch thick mattress
Utilisez ces trous pour s'adapter à un matelas de 6 pouces d'épaisseur

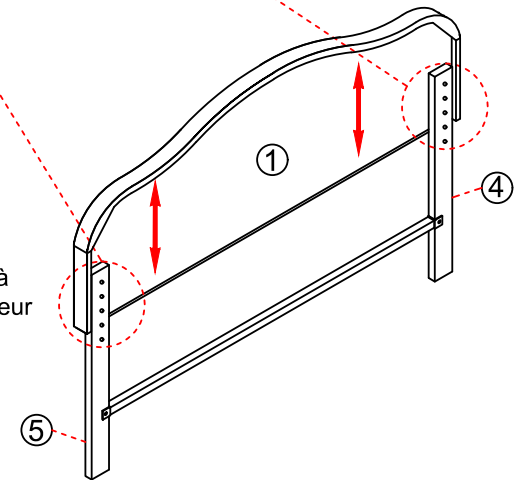

8 / 20

3



G*1PC

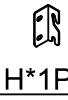

H*1PC



M8*18

A*4PCS



E*1PC

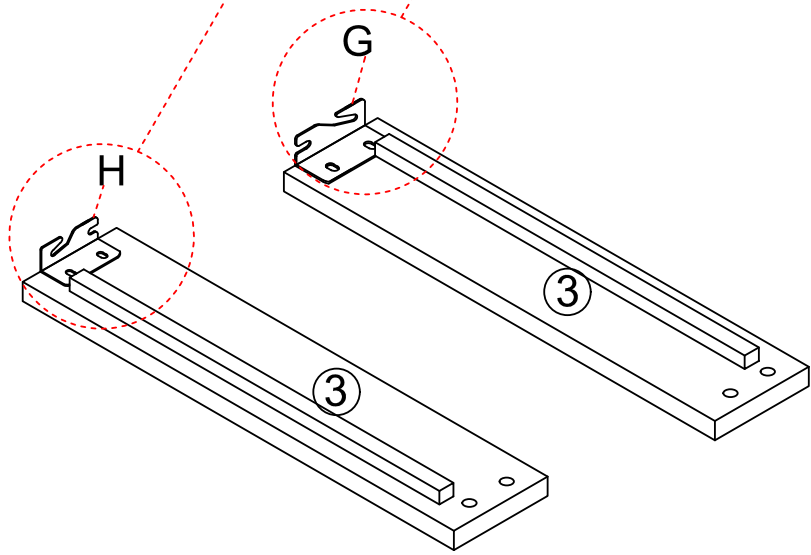
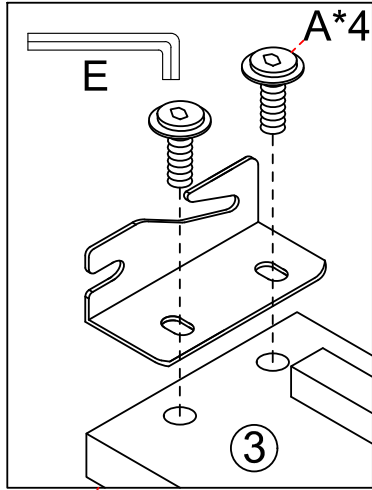

9 / 20

4

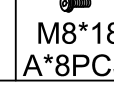

M8*18

A*8PCS

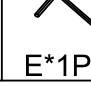

E*1PC

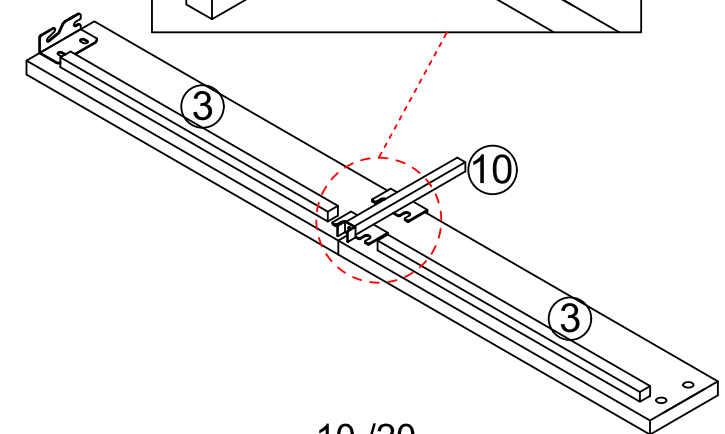
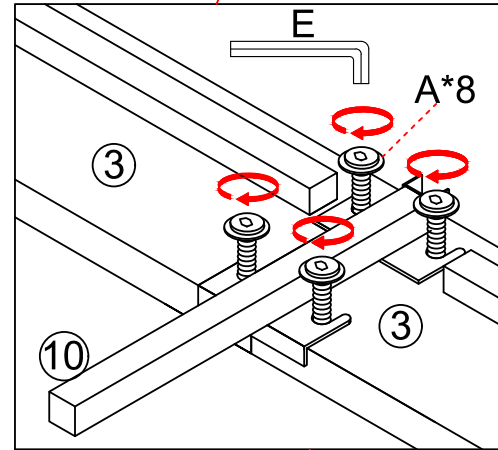
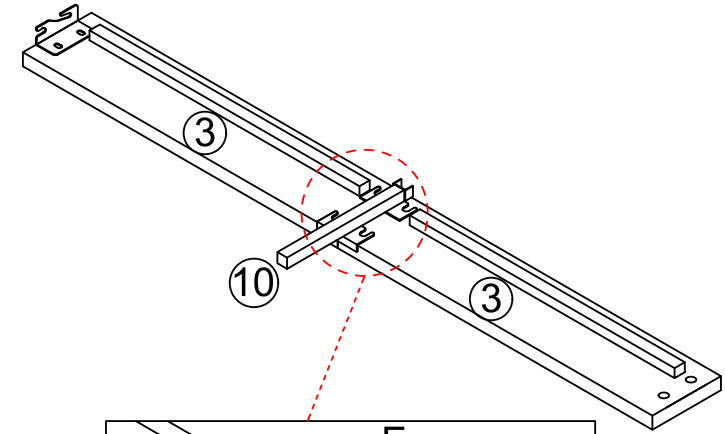

10 / 20

7 M8*25 B*4PCS E*1PC

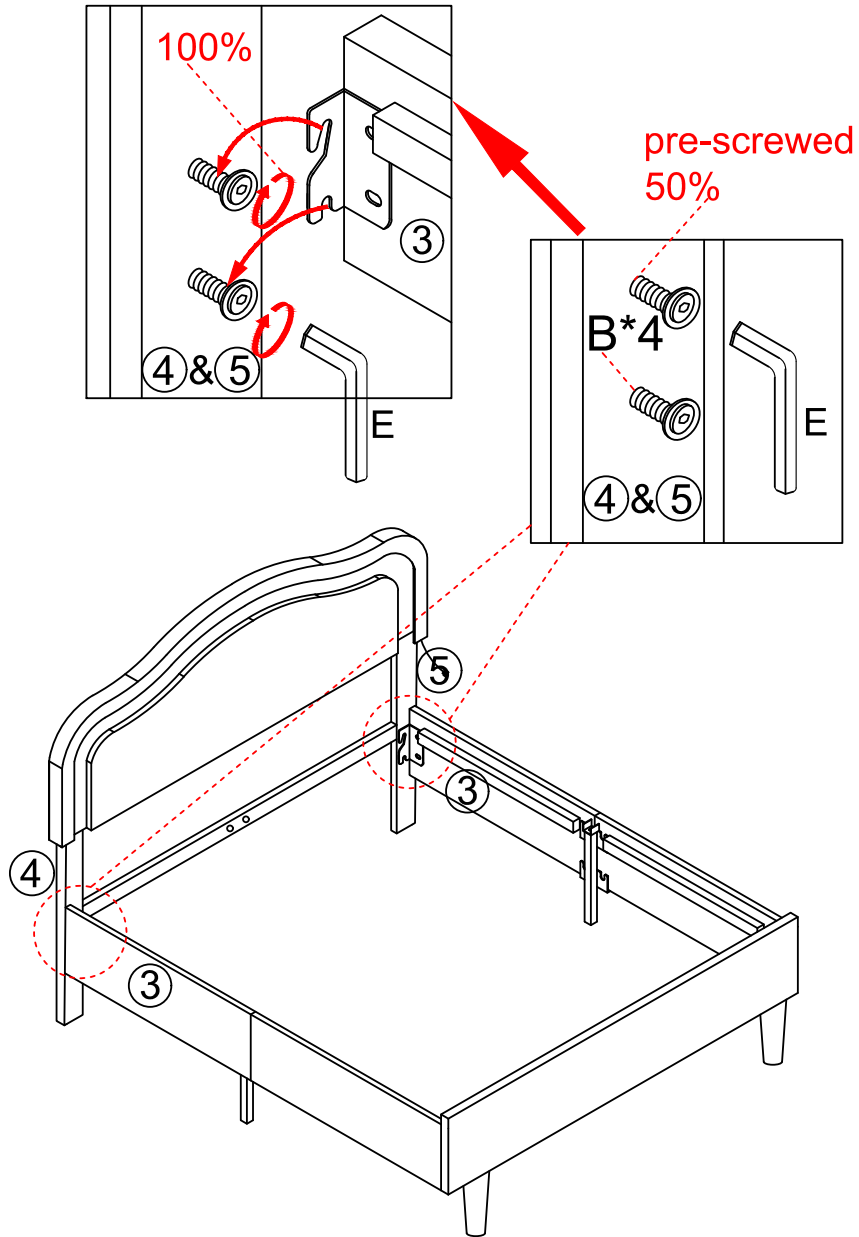

13/20

8 M8*25 B*2PCS M8*45 C*2PCS E*1PC

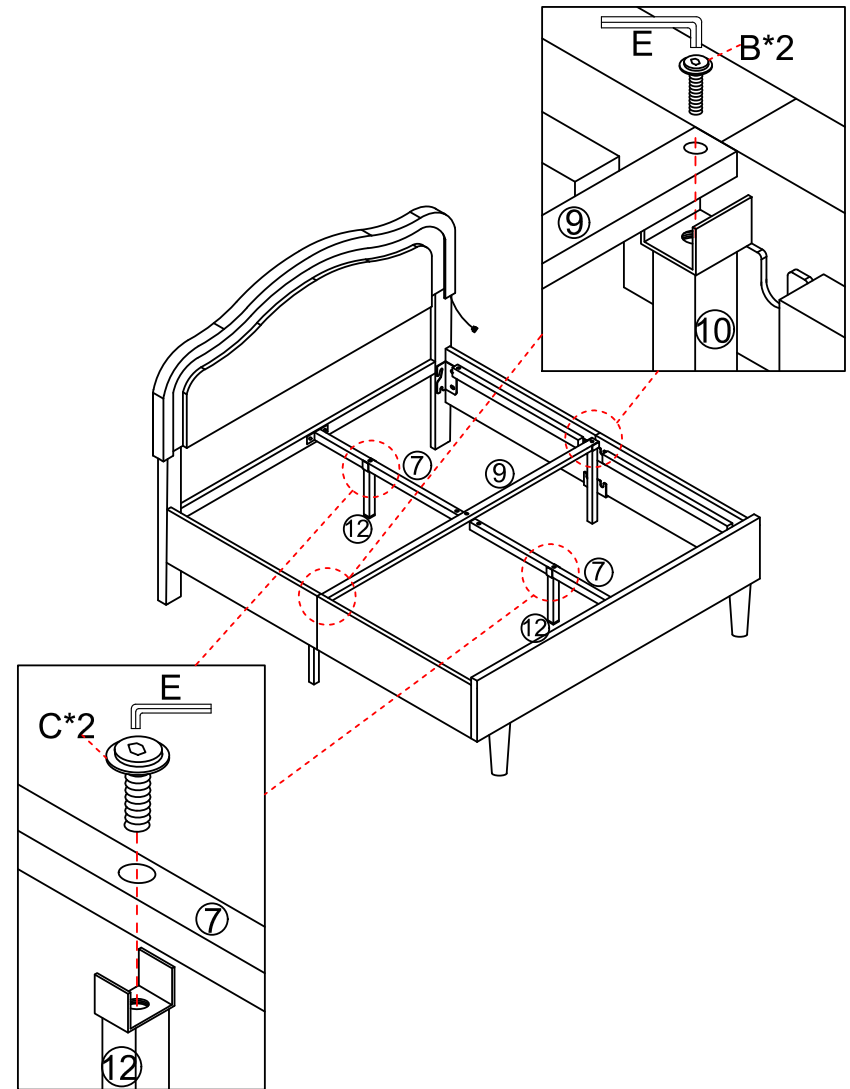

14/20

9

M8*25 B*4PCS
M8*45 C*3PCS
E*1PC

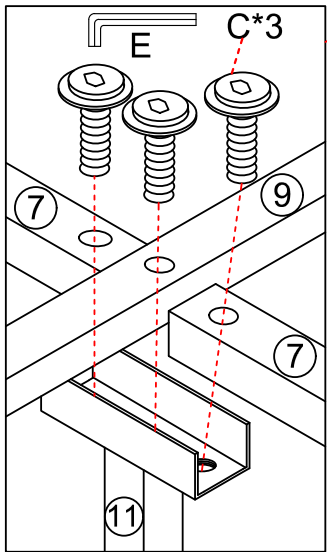
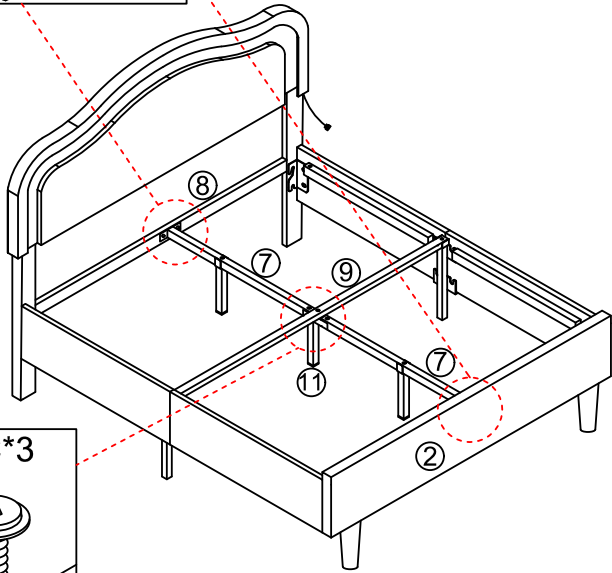
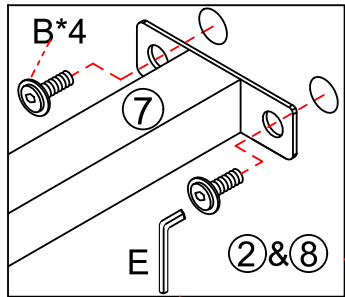

15/20

10

J*1

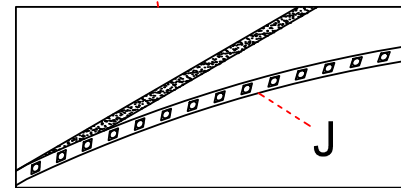
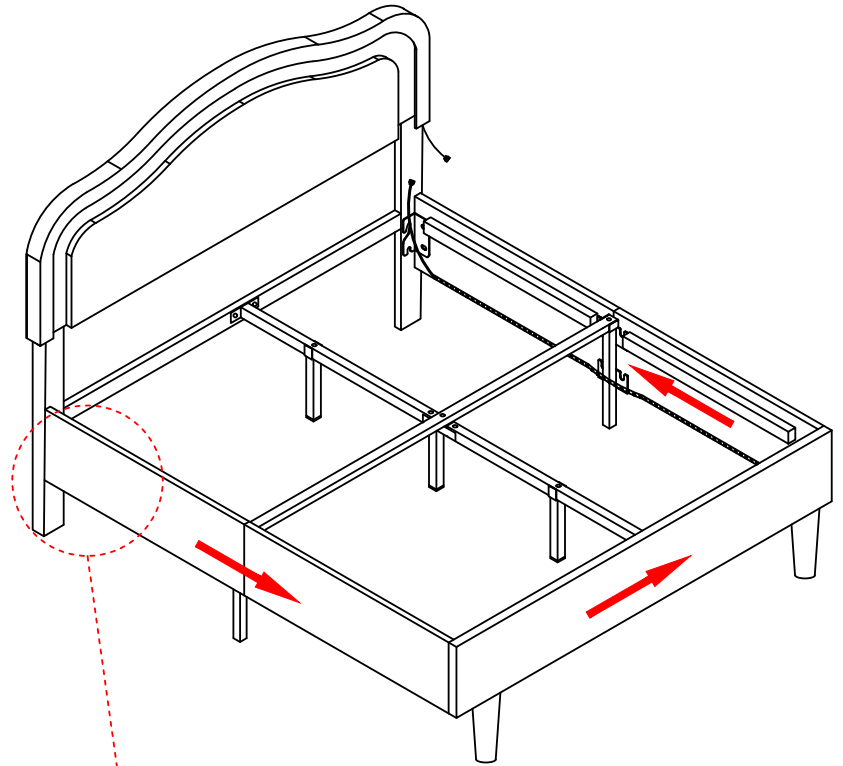

16/20

11 L*1PC K*1PC

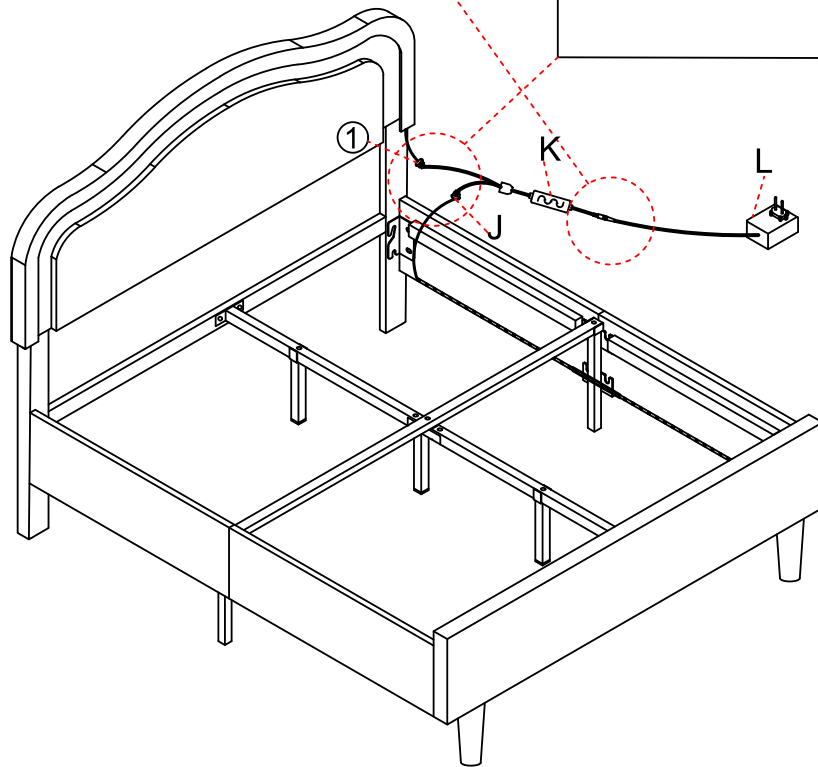
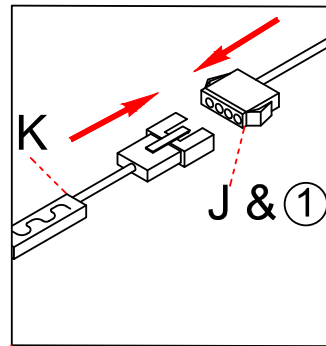
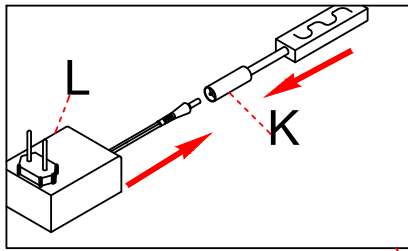

17/20

12

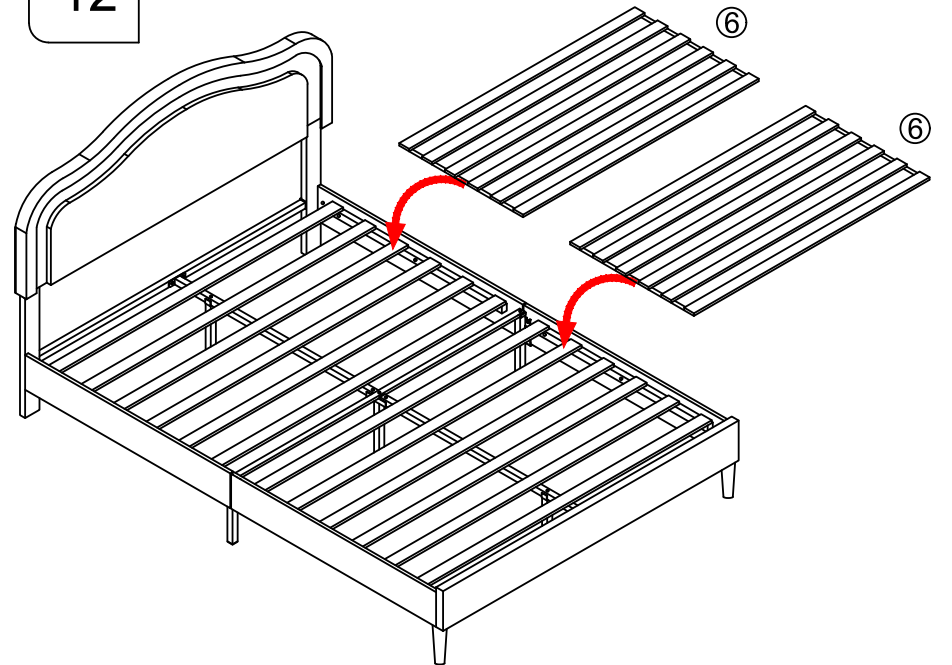

13

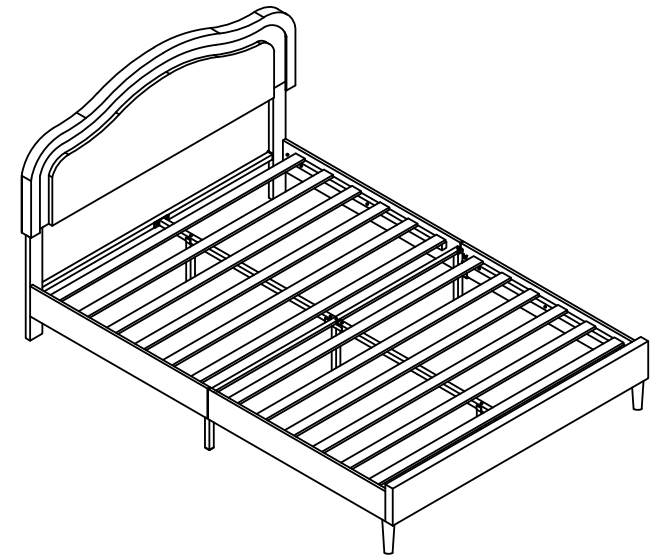

18/20

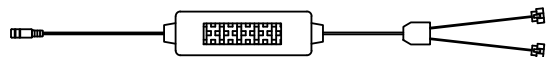

NOTICE:
 You can scan the QR code here and download an app that can control the color of the light strip like a remote control. When your phone plays music through the app, the color of the light strip will also change according to the strength of the music.

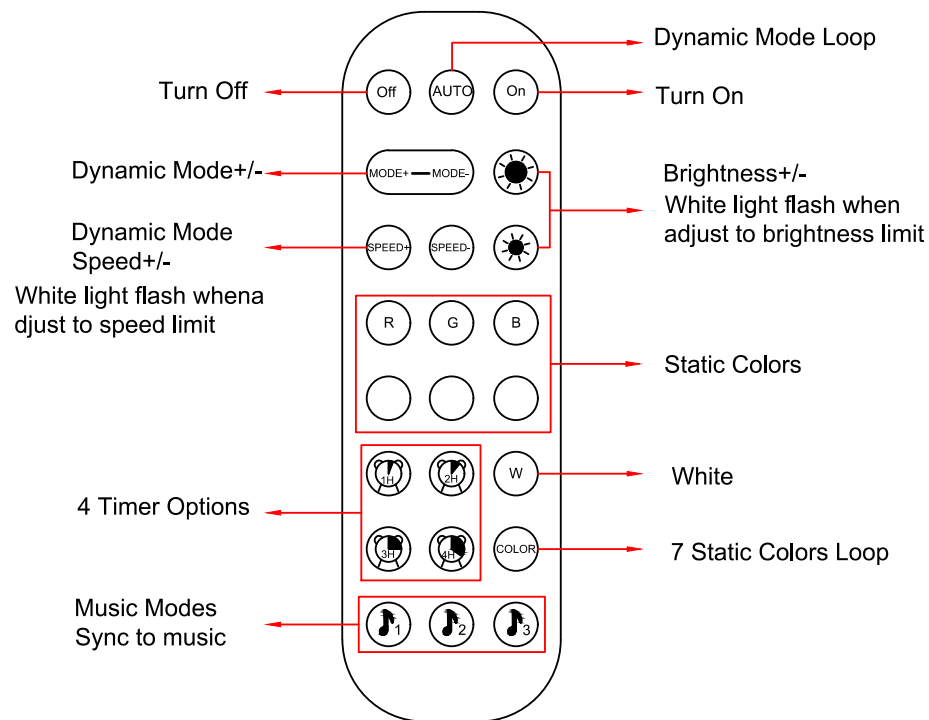

Notices

1. Please pull out the battery insulated plastic chip before using remote.
2. Press the lock key, the remote keys will be locked, press the lock key again, all the remote keys will be unlocked.



AVIS:
 Vous pouvez scanner le code QR ici et télécharger une application capable de contrôler la couleur de la bande lumineuse comme une télécommande. Lorsque votre téléphone joue de la musique via l'application, la couleur de la bande lumineuse changera également en fonction de la force de la musique.

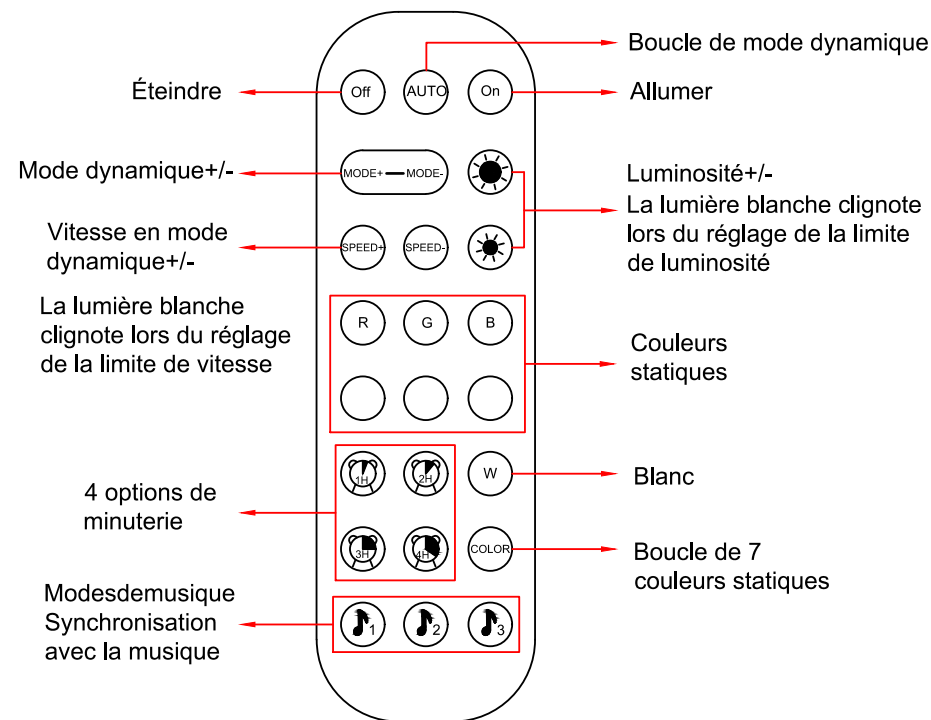

Avis

1. Veuillez retirer la puce en plastique isolée par batterie avant d'utiliser la télécommande.
2. Appuyez sur la touche de verrouillage, les touches de la télécommande seront verrouillées, appuyez à nouveau sur la touche de verrouillage, toutes les touches de la télécommande seront déverrouillées.