

ASSEMBLING & INSTALLATION INSTRUCTIONS

For Ceiling Mount Lighting Fixtures

WARNING! SHUT POWER OFF AT FUSE OR CIRCUIT BREAKER .

MOUNTING THE FIXTURE

1. Shut off the power at the fuse box or circuit breaker box. Remove the old fixture from ceiling, including the single bar.
2. Carefully unpack your new fixture and lay out all the parts on a clear area. Take care not to lose any small parts necessary for installation.
3. Thread end of nipple (C) into single bar (D) until snug. place lock washer (B) over end of nipple protruding through single bar and thread hex nut (A) onto nipple until tight.
4. Take this single bar assembly and mount to ceiling junction box with junction box screws (E). Tighten screws securely with screwdriver. The side of the single bar marked "GND" must face out.
5. Hold the pan (F) towards the single bar and connect the electrical wires as follows (See Fig.2). Connect the black wire from the fixture to the black house (hot) wire; connect the white wire from the fixture to the white house (neutral) wire. Make sure all wire nuts are secured. You may wrap the connections with electrical tape. If your outlet box has a ground wire (green or bare copper) connects fixture's ground wire to it. Other wise attach the bare copper fixture wire to the green ground screw on the single bar. Tuck the wire connections neatly into the ceiling junction box as you are holding the fixture assembly toward the ceiling.
6. Raise pan (F) to the junction box, aligning nipple on single bar with center hole in the pan and lock it securely with the knurled nut (G).
7. Install the light bulbs in accordance with the fixture's specifications. **DO NOT EXCEED THE MAXIMUM WATTAGE RATING!**
8. Put the glass shade (H) into the frame(I), Raise the assembly to the pan(F), aligning small nipple on the pan with small hole in the frame(I), lock it with the ball nut(J).

Your installation is now complete. Return power to the junction box and test the fixture.

Fig.1

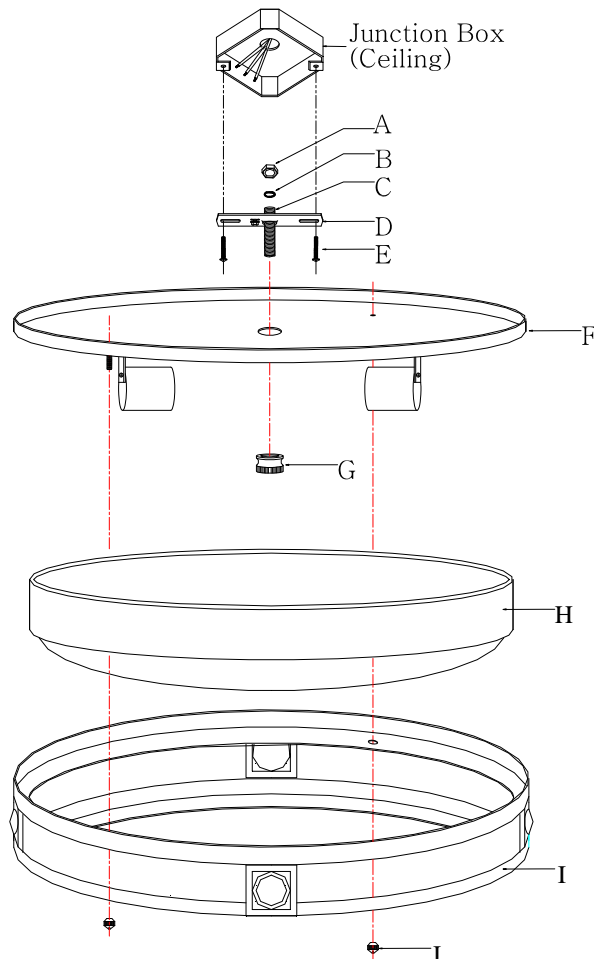

MIN 90°C SUPPLY CONDUCTORS

Fig.2

