

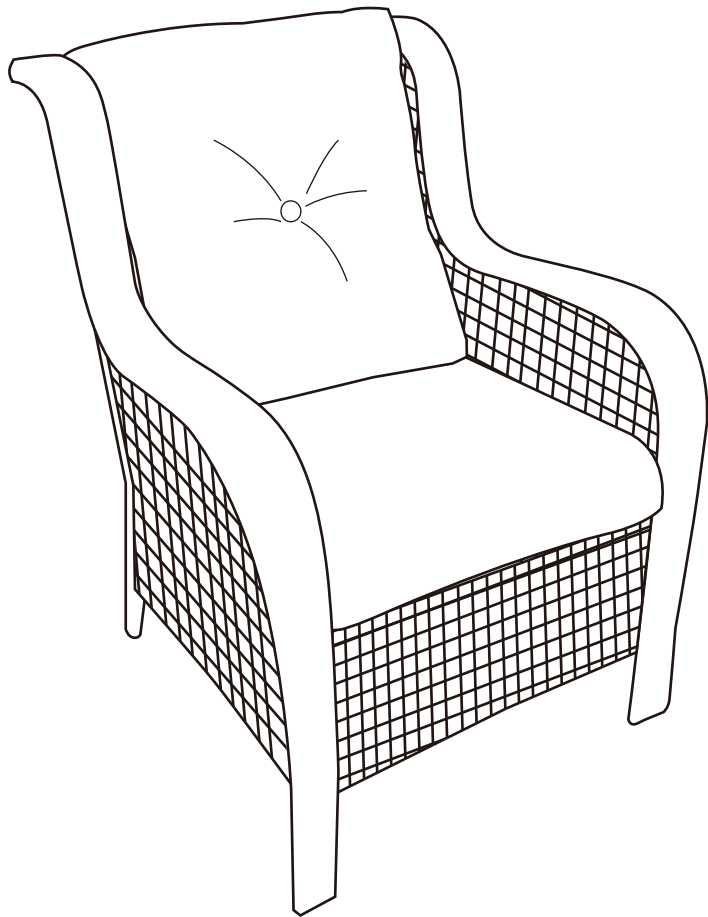







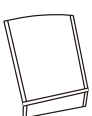

Installation & Assembly

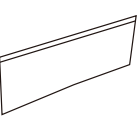

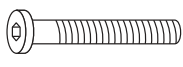
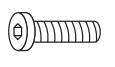
*** Don't fully tighten all the bolts till the very end!**

	PART LIST	DESCRIPTION	QTY
A1		LEFT ARM	1
A2		RIGHT ARM	1
B		BACK	1
C		SEAT	1
D		FRONT PANEL	1
E		WASHER -- M6	10
F		BOLT -- M6 x 40mm	4
G		BOLT -- M6 x 35mm	8
H		HEX WRENCH	1
I		Seat Cushion	1
J		Back Cushion	1

PRE-ASSEMBLY PREPARATION:

- Please read through the instructions before beginning assembly.
- Clear out the space for assembly and lay out all of the parts based on the Parts List, extra room will allow you to easily determine if all the pieces are present.
- Keep small parts and pieces away from children until fully assembled.

Step 1: Attach left arm (A1) and right arm (A2) to back panel (B) with 4pcs bolts (F) and 4pcs washers (E).

* Do not fully tighten bolts until the entire frame is assembled.

* Notice the position of left arm (A1) and right arm (A2), swapped arms would cause assembly failure. (Side wall of arm should be towards inside)

Step 2: Place the front panel (D) to arms (A1)&(A2) with 4 pcs bolts (F) and 4pcs washers (E), using hex wrench (H) .Note: Don't fully tighten the bolts

Step 3: Place the seat C to back(B) and front panel(D) with 4pcs bolts (G) and 4pcs washers (E).

Verify the alignment and adjust, now fully tighten all the bolts using hex wrench (H). Put seat cushion and back pillows on.

* Due to design and weaving handicraft limitation, it may has around 1/2 in. gap between arms and back panel after assembly. It is normal and will not affect outlooking and daily usage.

