

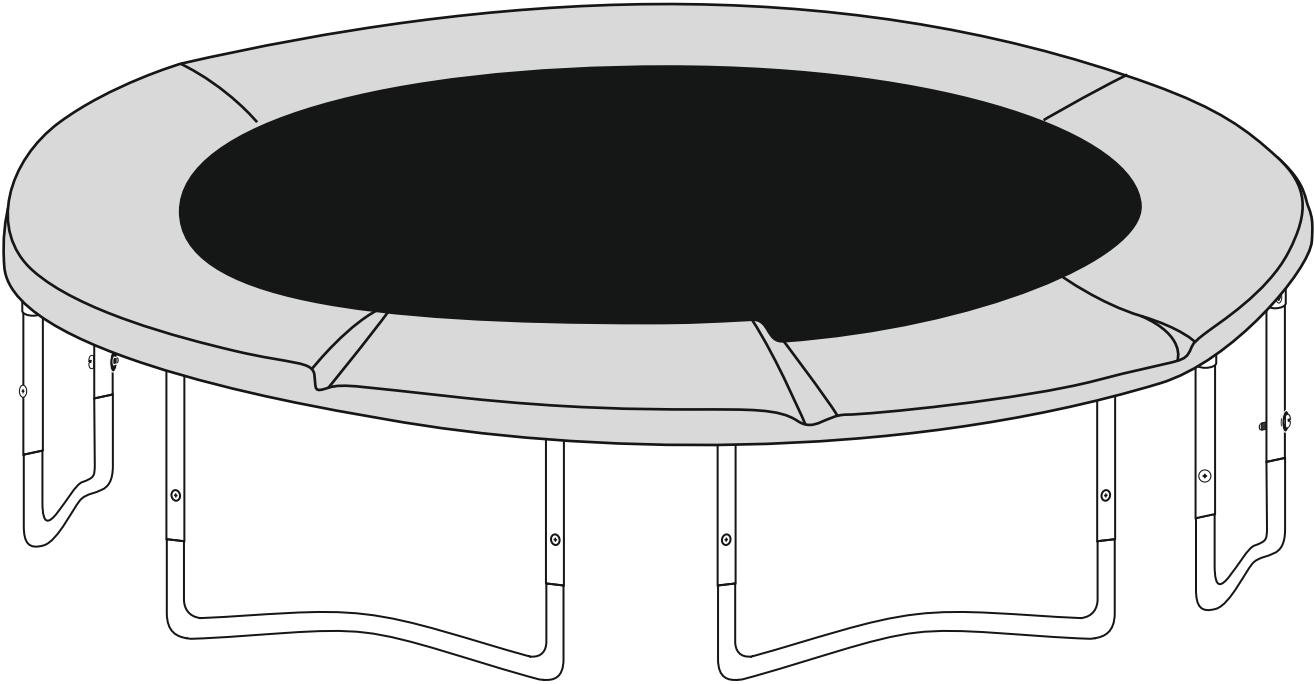

Upper Bounce[®] Trampoline Set User Manual

Assembly, Installation, Care, Maintenance and Use Instructions.

WARNING: Read these materials prior to assembling and using this trampoline.



Models

UBT01-12	UBT01-14
UBT01-15	UBT01-16

Manual Version #03

Headquarters :

Upper Bounce[®] Inc. 2 Mill St. Cornwall NY 12518, 1-888-965-3331, www.upperbounce.com



USA

UK



Call us

1-888-965-3331

020-3150-0484



Email us

support@upperbounce.com

support@upperbounce.co.uk



Check out our website

www.upperbounce.com

THANK YOU FOR PURCHASING THE UPPER BOUNCE® TRAMPOLINE PART

Simply follow the assembly and safety instructions in this manual and you will soon be starting your **UPPER BOUNCE®** exercise program and fun and be on your way to a happier, healthier lifestyle.

MONDAY - THURSDAY 9:30 A.M. - 5:00 P.M. Eastern Time.	FRIDAY 9:00 A.M. - 12:00 P.M. Eastern Time.
--	--

TABLE OF CONTENTS

	Page
Introduction, Guidelines, Additional Tips, Warnings	3-7
Trampoline Frame Parts List	8
Trampoline Frame Assemble	9-10
Trampoline Mat Assembly	11
Trampoline Pad Assemble	12
Testing The Trampoline	13
Fundamental Bounces Techniques	14
Enclosure Set Model Names	15
Replacement Parts List	16

INTRODUCTION

Before you begin to use this trampoline, you must read all the information in this manual. Just like any other type of physical recreational activities, participants can be injured. To reduce the risk of injury, please read carefully and follow the appropriate safety rules and tips.

- Misuse and abuse of this trampoline is dangerous and can cause serious injury!
- Trampolines are rebounding devices which propel the performer to unaccustomed heights through a variety of movements. So always use caution when playing on a trampoline.
- Always inspect the trampoline before each use.
- Proper assembly, care and maintenance of product, safety tips, warnings and proper techniques in jumping and bouncing are included in this manual. All users and supervisors must read and familiarize themselves with these instructions. Anybody who chooses to use this trampoline must be aware of their own limitations in regards to performing various jumps and bounces with this trampoline.

Initially, you should get accustomed to the feel and bounce of the trampoline. The focus must be on your body position and you should practice each fundamental bounce until you can do each skill with bounce before moving on to more difficult and advanced bounces. Do not behave recklessly on the trampoline, emphasis must be made on good control and the mastering of various bounce techniques.

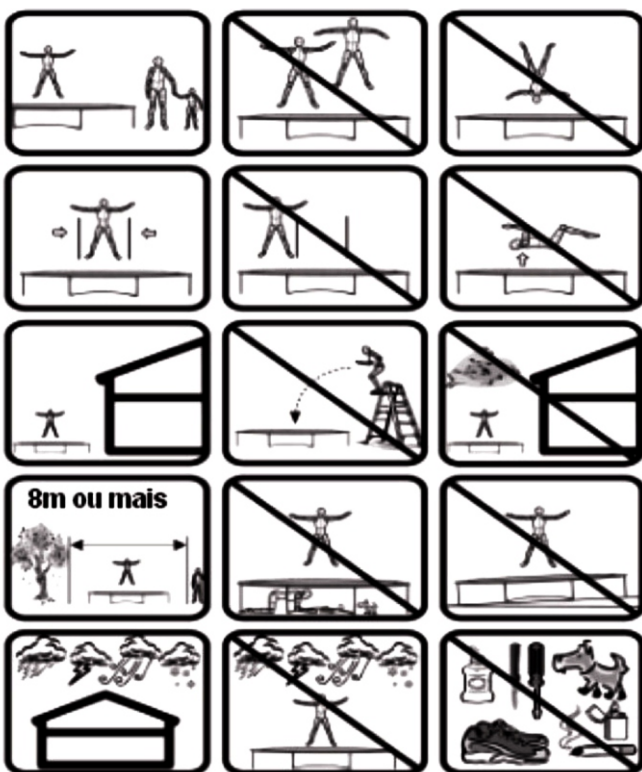

No more than one person is allowed on the trampoline! Multiple jumpers increase the risk of injury resulting in min-air collisions.



Do not perform somersaults (flops) as this will increase the chances of landing on your head or neck. Paralysis or even death can result.

TRAMPOLINE GUIDELINES

1. General Instructions

1.1 Purpose

- The product is intended for home/domestic use only and is not suitable for professional or medical uses.
- The maximum weight is 400 lbs. Overloading the trampoline above the recommended user weight will cause damage to the trampoline which is not covered by warranty.

1.2 Danger for children

- Do not let children unsupervised near this product. Carry out the necessary safety precautions and supervise all trampoline activities. Be aware that the packaging material is not suitable for children. There is a danger of suffocation!
- Trampolines over 51 cm (20 inches) in height are not recommended for children under 6 years of age. Children do not recognize potential dangers from this product. Keep children away from this product, it is not a toy. the product has to be stored out of reach of children and pets.

1.3 Attention - Product Damages

- Do not alter the product. Only use original spare parts. Repairs should only be carried out by qualified technicians. Improper repairs can compromise the safety of your trampoline. use this product only as described in this manual.
- Protect the product against humidity and high temperatures.

1.4 Advice for the assembly

- The assembly of the product must be done carefully by at least two able-bodied adults. If in any doubt, ask a technically qualified person.
- Before you start assembling the trampoline, read all the instructions in this manual.
- Remove all packaging materials and lay down all parts on a free space. This gives you an overview and simplifies the assembly procedure.
- Check with the parts list that no parts are missing. Dispose of the packaging material when the assembly is completed.
- Beware that when using tools or doing technical work, there is always a risk of injury.
- Therefore assemble the product carefully.
- Create a danger free environment, for example: do not let tools scattered around the workspace.
- Store the packaging material in a way that cannot cause any danger. Foils and plastic bags are dangerous for children (danger of suffocation)!

- After installing the product according to the instruction manual, please make sure that all screws, bolts and nuts are correctly installed and tightened and that all joints are tightly fixed.
- A clearance space of at least 7.3 ft is necessary above the trampoline. An appropriated clearance must be kept between the trampoline and possible sources of danger, such as electric cables, tree branches, playing devices, swimming pools and fences.
- The trampoline must be set up properly before use.
- Never set up the trampoline in rainy, windy or stormy conditions, especially lightening conditions. It is recommended that the trampoline be taken apart and stored in bad weather.
- The metal frame of the trampoline will conduct electricity. Lighting, extension cords and all electrical equipment must never be allowed to come in contact with the trampoline.
- The trampoline must always be used in a well-lit area.
- Do not place any objects under the trampoline.
- The trampoline in the vicinity of other leisure devices and constructions must not be used.
- When assembling or disassembling, please use gloves to protect your hands.

Additional tips

- For additional stability you can place sand bags on the trampoline legs. This will prevent the trampoline from tipping over in the event of any sideward's force.
- Do not use during pregnancy.
- Do not use when suffering from high blood pressure.
- Do not wear shoes while jumping. This will damage the jumping mat which is not covered by the warranty.
- Do not smoke while on the trampoline.
- Do not put cigarettes, Pets, sharp objects or any other foreign objects on the trampolines.
- Do not use the trampoline when under the influence of alcohol or drugs.
- Do not sit or lean on cover pads as it needs to be feeble so it can move with the jumping mat. Please do not allow small children to pull themselves up the trampoline by using the cover pads. Tears in stitching caused by obstructing frame pads are not covered by warranty.
- Place trampoline on level ground. Preferably on grass. Locating the trampoline on hard surface will add stress to the frame and overtime cause damage which is not covered by the warranty. Placing the trampoline on uneven surfaces may result in the trampoline tipping over.
- Do not expose the trampoline to direct contact with open flames.
- Secure the trampoline against unauthorized use.
- Do not use if trampoline is wet.
- Trampoline should be tied down with anchors during windy conditions or disassembled and stored away.

WARNING:









1. Please ensure that the safety enclosure net zipper is 100% closed and all three entrance hooks are re-hooked before jumping.
2. Do not intentionally jump into the safety net, it is only designed to stop persons from falling off the trampoline. Intentional jumping into the safety net may cause the trampoline to topple over, or may damage your net. Abuse of the safety net is considered negligent use which is not covered by the warranty, please refer to the disclaimer.

2. Safety Instructions for Trampolines

- All users of the trampoline need a supervisor. Regardless of the age or experience of the user.
- The safety instructions of the trampoline should always be considered and obeyed.
- Somersaults should be avoided. Incorrect landings on the trampoline can lead to injuries, particularly to the back, neck or head. Injured may include paralysis. Or even death.
- Only one person should use the trampoline at a time. Multiple users on the trampoline will increase the risk of collision.
- The trampoline has to be examined for damaged, wearing or defective part before each usage, as it can impair the overall safety of the trampoline. The damaged, wearing or defective parts should be replaced immediately. In the meantime the trampoline must be restricted from access.
- No clothes with hooks or parts may be carried when jumping on the trampoline, in order to avoid hooks getting caught.
- The trampoline must be set up only on a flat ground and non-slippery surfaces.
- Strong winds can blow the trampoline away. If strong winds are predicted. The trampoline must be moved to a protected place, and taken apart. Or fastened to the ground with cords and herrings. At least three anchorages are necessary. it is not enough to anchor the pennants in the ground since the can tear out of the patch cords.
- Try to avoid moving the assembled trampoline, it could bend during transportation. Should it be necessary to move the trampoline, please consider the following: at least four people must be evenly spaced around the frame to lift the trampoline off the ground. The trampoline must be carried horizontally, and if the frame shifts position use four people to draw the trampoline into shape.
- Trampoline are jumping devices, enabling the user to jump to unusual heights as well as into a multiplicity of body movements. Jumping into the trampoline. Hitting the frame, cover pads or incorrect landing on the trampoline can lead to injury.

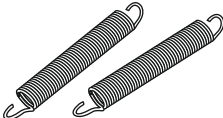
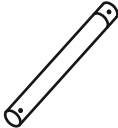
- Users should be familiar with the user manual. This manual contains assembly instructions, selected precautionary measures as well as recommendations for servicing and maintenance of the trampoline, in order to ensure a secured and fun use of the trampoline.
- It is the responsibility of the owner or the supervisor to guarantee that all users of the trampoline are informed about all safety rules and that there is sufficient space around the trampoline as a safety precaution.
- Never place the trampoline near water, and keep sufficient space around it as a safety precaution.
- Beware of moving parts. Which could catch your arms and legs.
- Do not stick any foreign objects into the trampoline.
- Do not allow anyone or any object to go under the trampoline while someone is jumping on the mat. The jumping mat is flexible and the downward force created by someone jumping can cause serious injuries.
- Implement all safety rules and make yourself familiar with the information in the user manual.
- The trampoline can only be used, if the jumping mat is clean and dry. Worn or damaged jumping mats should immediately be replaced.
- Object, that could be dangerous, should be vacated from the area.
- Avoid unsupervised use of the trampoline.
- Do not use the trampoline under influence of alcohol or drugs (incl. medication.)
- Learn the fundamental jumping techniques thoroughly. Before trying difficult jumps, see section fundamental bounce techniques.
- Carefully climb onto trampoline. Do not jump into it directly. Do not use the trampoline as jump board for other articles. For more information, see section-accident categories : mounting and dismounting.
- For further information or exercise instructions, you can turn to a trained trampoline teacher.

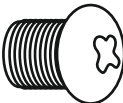
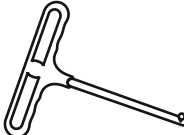
TRAMPOLINE FRAME PARTS LIST

ITEM	PART IMAGE	MODEL	12 FT 6 legs	14 FT 6 legs	15 FT 6 legs	16 FT 6 legs
A		Frame Cover	1	1	1	1
B		Jumping Mat	1	1	1	1
C1		Top Rail	6	6	6	6
C2			6	6	6	6
D		Springs	72	72	84	96
F		Leg Extensions	12	12	12	12
G		W-Shaped Leg	6	6	6	6
H		Screws	36	36	36	36
I		Spring Tool	1	1	1	1
J		Screw Driver	1	1	1	1
K		LEG STABILIZER	12	12	12	12

TRAMPOLINE FRAME ASSEMBLY

Warning :

2 adults in good physical condition are required for the following assembly. Wear proper shoes and maintain balance to prevent a fall. Failure to follow all instructions and warnings exactly may result in serious injury.

Step 1- Frame Layout

Lay out the trampoline parts on the ground so that you start to form a circle with the top rail sections. Make sure to keep all the tubes in the same direction all around the trampoline frame.

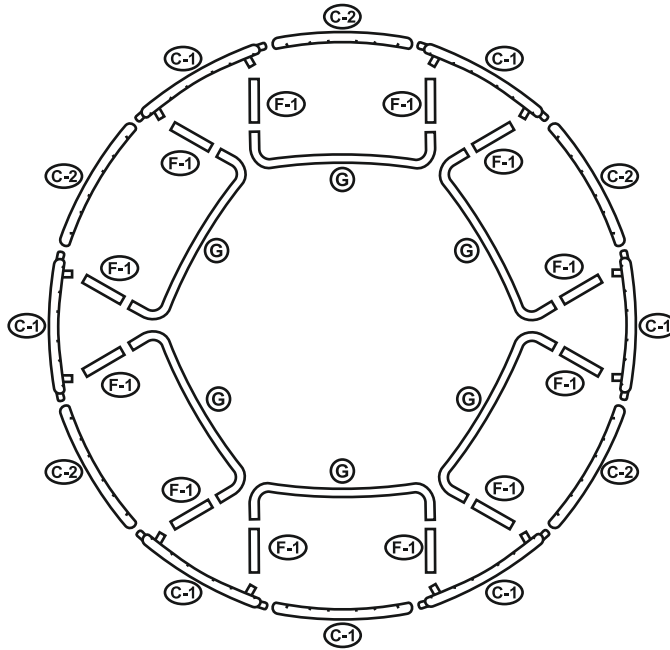

Step 2- Assemble The Rail with the Legs

Assemble each of the Leg base to the Leg Extension. Attach the leg extensions to the leg base and tightly secure together with the screws. Part F to part G. Repeat this step for all legs.

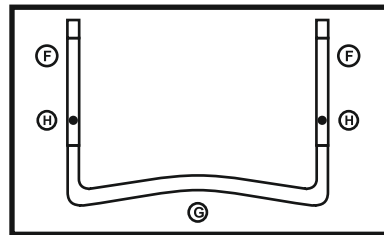
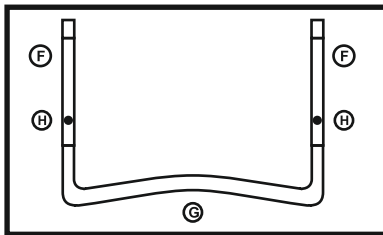

Step 3

Connect one C-1 and one C-2 together then continue the following pattern: 'C-1' + 'C-2' + 'C-1' + 'C-2' continue until you form a large circle. Joining the last bar may require two or more adults in good physical condition. With a second person holding the opposite end, bring both sides of circle together and have them secured.

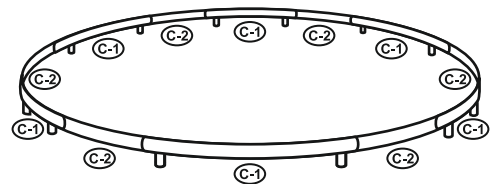

Note:

If your frame does not seem sturdy this should not worry you, for the trampoline mat will tighten it up.

Step 4 - Connect the legs bases to the top rail circle.

Attach the leg supports you assembled in step 2 to the top rails C-2 part like the picture shown. Repeat this step until you have the full frame standing.

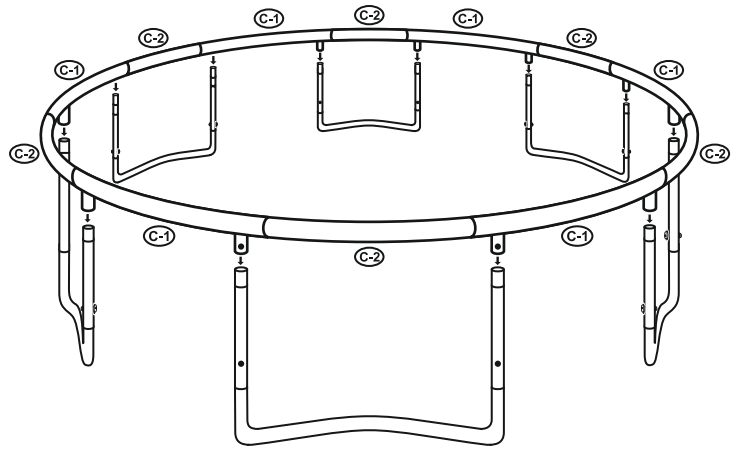

Step-5

Secure the leg supports to the top rail frame with screws tightly

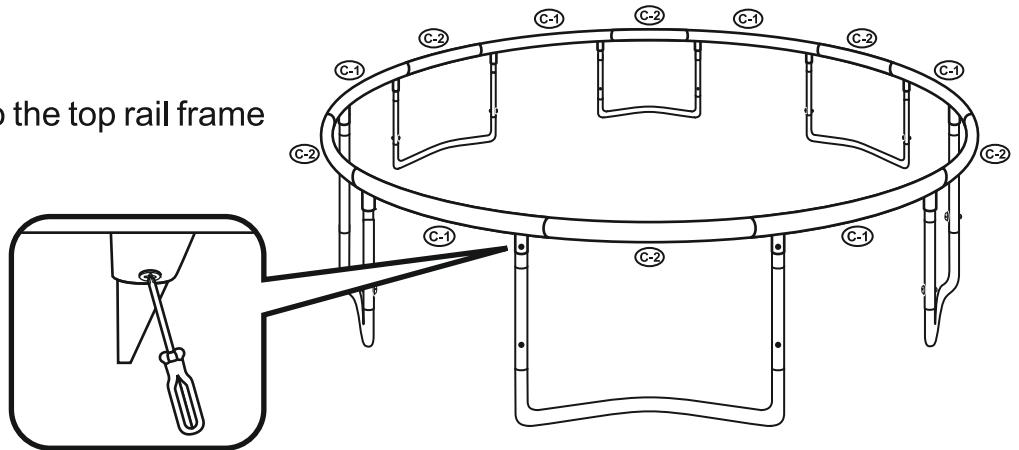

Step-6

Secure together with screws underneath the C-2 parts to hold together the top rail.

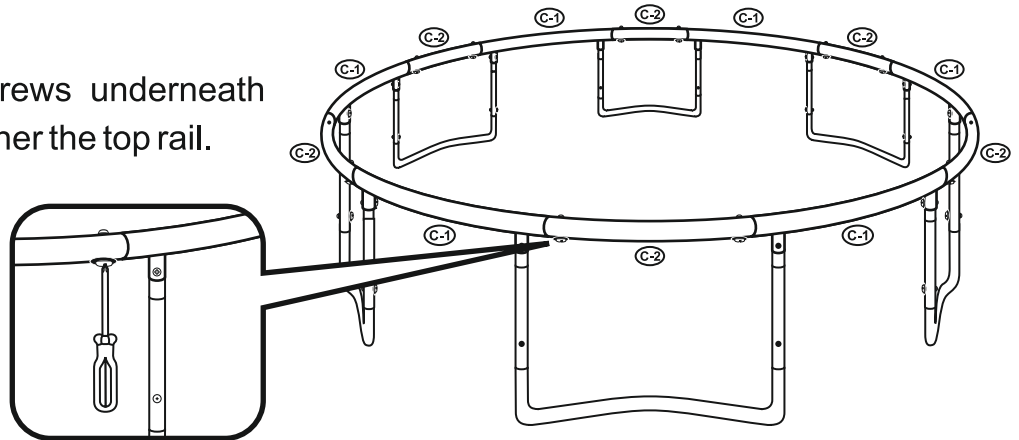

Note:

If you are unable to screw it together because the holes are not matching please wait after installing the mat it will stabilize then.

Add stabilizer Part K to bottom of the legs, 1 for each side of leg.

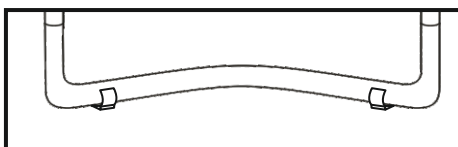

Now, the frame assembly is complete.

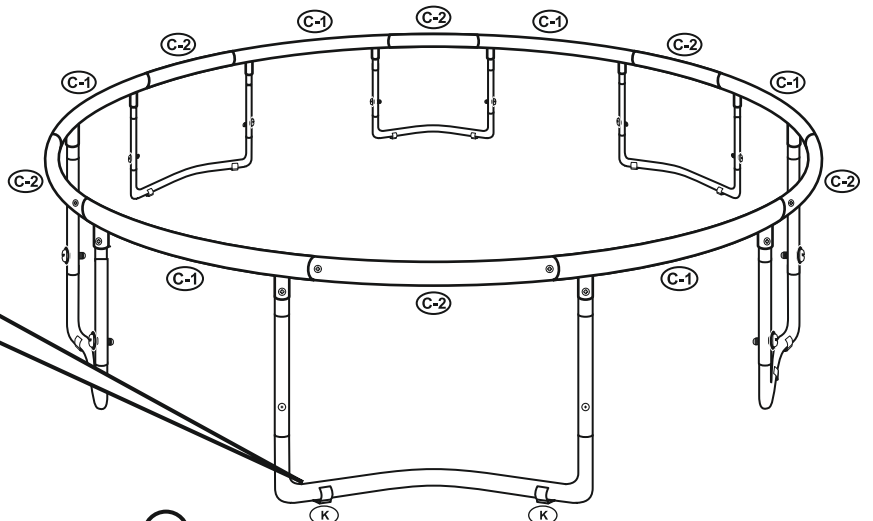

STEP 6 - Trampoline Mat Assembly

Warning: Be careful where you place your hands during spring assembly.

as connector points can pinch!

1. Lay out the Trampoline Mat inside the frame.

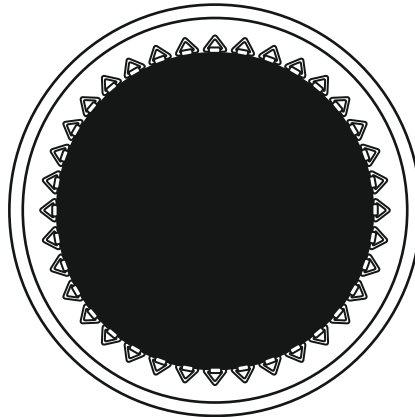

2. Connect 4 springs to top rail 1/4 circle apart from each other as figure below.

Note:

Make sure the difference from 1 spring to the other should be the same as the holes of the frame.

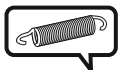
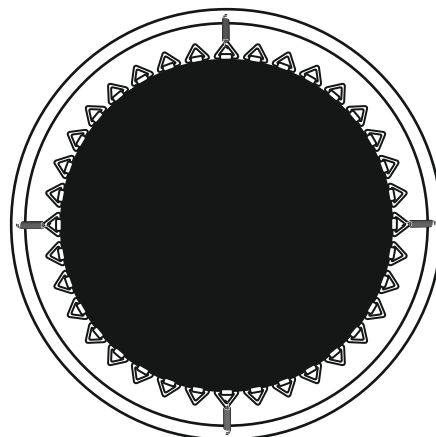

1

2

3

4

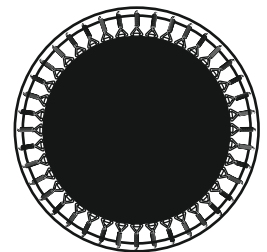
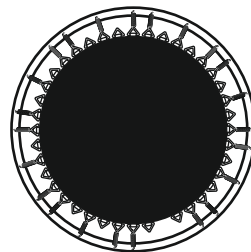
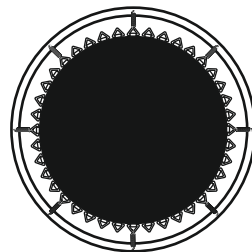
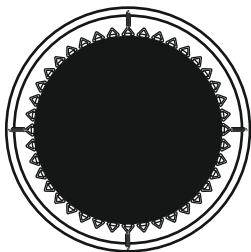

First connect the 4 springs
1/4 circle apart from each other

Connect all middle
springs as figure

Then continue,
connecting every few springs

Complete the
rest of the springs

How to use the spring pulling tool

Step I: Hook on one end of the spring to the mat's triangular hooks.

Step II: Extend tool and link up spring hook with eyelet on tool pull the handle of the tool in direction shown until spring hook links up with the frame.

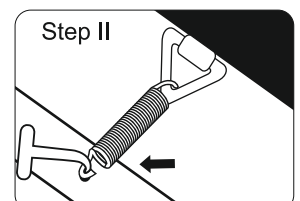
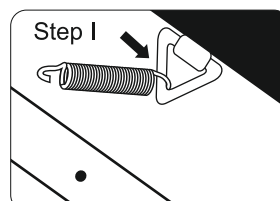

STEP 7- Cover Pads Assembly

➤ The trampoline is at a stage close to completion with all the springs in place. Before using the Trampoline please attach the provided safety pads.

Step I: Lay out the safety pad around the outer edge covering all the springs, as shown on right.

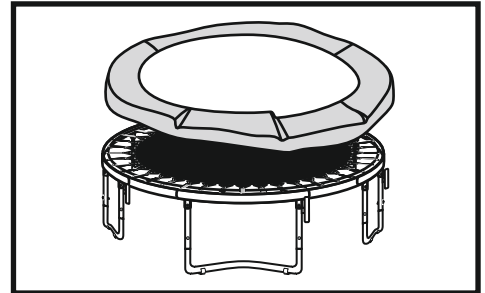

Step II: The pad has double tie strings with an S shaped hook at the end. Attach one S shape hook to the springs of the mat, and the other S shape hook to the V-rings of the mat. Attach the hooks from underneath the mat.

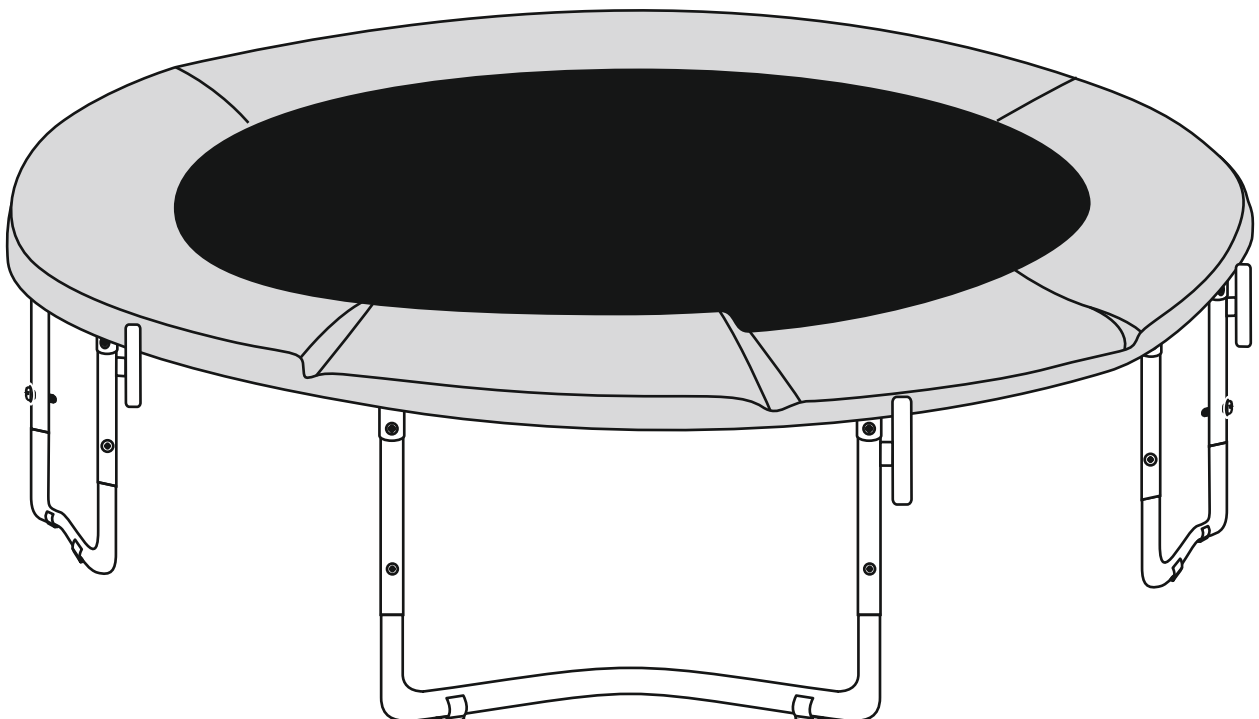
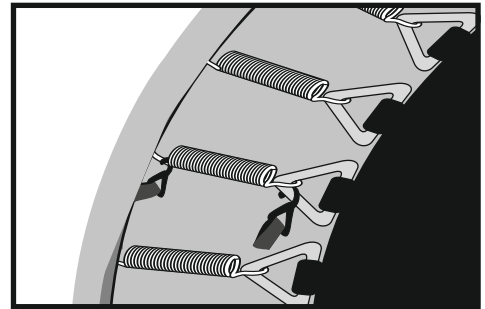

TESTING THE TRAMPOLINE

After assembling the trampoline, it is important that you perform the following safety checks:

Trampoline Safety Checks:

- Using a screw driver, check if all the screws are tightly secured.
- Look under the trampoline and check all the springs are hooked securely to the frame and triangle rings.
- Move the trampoline around and check the sturdiness of the frame.
- Using your two hands, put your body weight on one section of the trampoline and release to check that the floor is even.
- Inspect the cover pads and check if they completely cover the springs and frame.
- Make sure the strings of the pads are tied securely.

Enclosure Net Safety Checks:

- Hold onto pole net jacket and check that all the enclosure poles are sturdy by shaking it.
- Check the enclosure net and pole jacket for any tearing in the stitching or material.
- Check the enclosure net zipper and entrance hooks function properly.
- Check to see if all safety enclosure hook are attached to the triangle ring under the trampoline.

Once all the checks are performed and the trampolines has passed all the initial test (above), then your trampoline have one person test the trampoline by jumping on the centre continuously for 5 minutes. If the trampoline feels sturdy then your trampoline passes the test. Congratulations, you have completed the trampoline assembly! Remember to abide by all the safety rules. Have fun, play safe...

PLEASE NOTE:

AS ALREADY MENTIONED IN THE INSTRUCTION MANUAL CERTAIN WEAR AND TEAR PARTS HAVE TO BE REPLACED FROM YOUR SUPPLIER.

FUNDAMENTAL BOUNCES TECHNIQUES

All trampoline users are recommended to understand and perfect these fundamental bounces.

THE BASIC BOUNCE

- Start from a standing position, feet shoulder width apart with head and eyes on the mat.
- Swing your arms forward and up and around in a circular motion.
- Bring feet together while in mid-air and point toes downward.
- Keeping feet shoulder width apart when landing on mat.

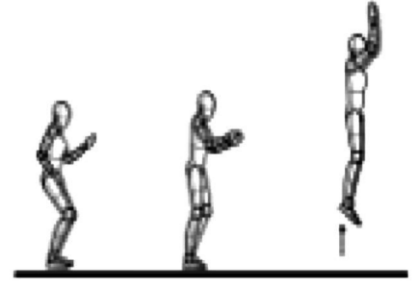

THE BREAKING MANEUVER

- Occasionally they may lose control of their jump and bounce wildly. Performing the breaking maneuver will allow the user to regain control of the jump and their balance.
- Start with a basic bounce.
- As you land, bend your knees sharply and this will allow you to stop your jump.

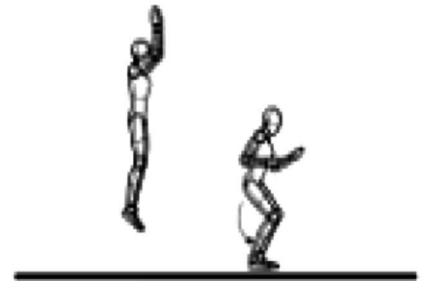

THE HANDS AND KNEES BOUNCE

- Start with a low controlled basic bounce.
- Land on your hands and knees keeping your back straight.
- Emphasis should be directed at a good four-point landing. And not on jumping height.



KNEE BOUNCE

- Start with a low controlled basic bounce.
- Land on your knees keeping back straight, body erect and use your arms to maintain balance.
- Bounce back to the basic bounce position by swinging your arms up.



SEAT BOUNCE

- Land in a flat sitting position.
- Place hands on mat beside your hips.
- Return to erect position by pushing with your hands.



To add an Upper Bounce® "Enclosure Set" to this trampoline please refer to this model names

Inside Type

Size 12	Size 14	Size 15	Size 16
UBES126	UBES146	UBES156	UBES166

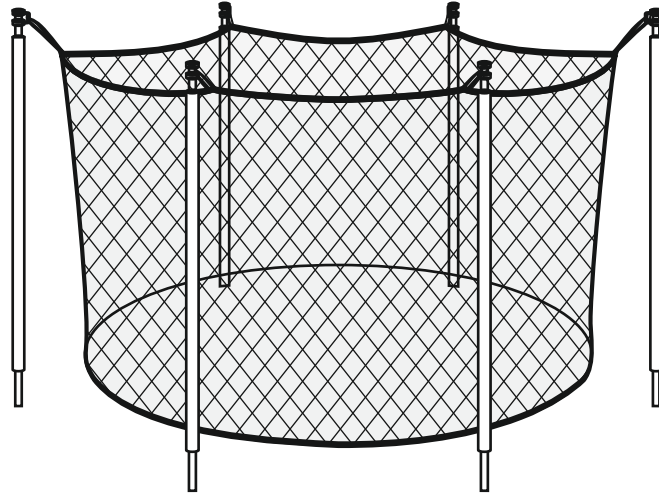

Outside Type

Size 12	Size 14	Size 15
UBESOS126	UBESOS146	UBESOS156

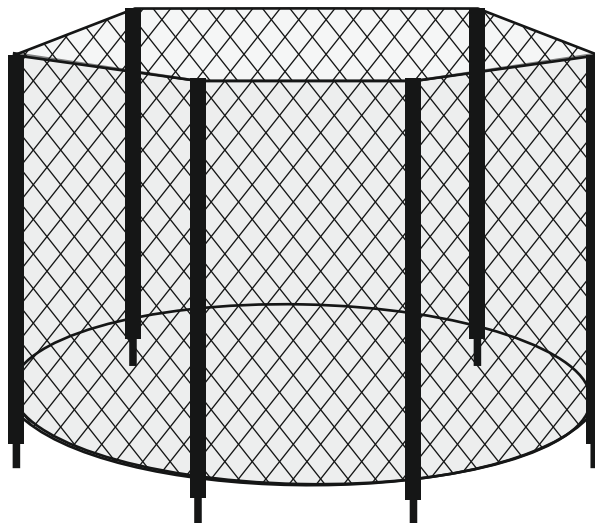

REPLACEMENT PARTS LIST

If you need to replace any part of your trampoline, you can look for the Upper Bounce parts list below for each item model name :

SIZE	JUMPING MATS	SAFETY PADS	SAFETY NETS				WEATHER COVERS	
	Example UBMAT-7.5 (Frame size) -42 (Amt of springs) -5.5 (Spring size)	Example UBPAD-S (Super) -7.5 (Frame size) -B (Blue) / P (Premium) / G (Green) / BG (Blue Green)	Strap Type Net (Inside) Example UBNET-7.5 (Frame size) -6 (Amount of poles)-IS	Strap Type Net (Outside) Example UBNET-7.5 (Frame size) -6 (Amt of poles)-OS	Sleeves on Top - Net (Arch) Example UBNET-7 (Frame size) -3 (Amt of arches)-AST	For Curved Poles Example UBNET-8FG (Frame size) -6 (Amount of poles)	Black Example UBWC-12 (Frame size) -BK (Black)	Blue Example UBWC-14 (Frame size) -BL (Blue)
SIZE 6								
SIZE 7			UBNET-7.5-6-IS	UBNET-7.5-6-OS	UBNET-7-3-AST			
SIZE 7.5	UBMAT-7.5-42-5.5	UBPAD-S-7.5-B					UBWC-7.5	
SIZE 8	UBMAT-8-48-5.5 UBMAT-8-56-5.5 UBMAT-8-60-5.5	UBPAD-S-8-B	UBNET-8-6-IS UBNET-8-4-IS		UBNET-8-2-AST	UBNET-8FG-6	UBWC-8	
SIZE 10	UBMAT-10-56-5.5 UBMAT-10-64-5.5	UBPAD-S-10-B	UBNET-10-4-IS UBNET-10-6-IS UBNET-10-8-IS	UBNET-10-8-OS			UBWC-10	
SIZE 11	UBMAT-11-60-5.5 UBMAT-11-72-5.5				UBNET-11-3-AST	UBNET-11FG-6	UBWC-11	
SIZE 12	UBMAT-12-60-7 UBMAT-12-72-5.5 UBMAT-12-72-7 UBMAT-12-80-5.5	UBPAD-S-12-B UBPAD-S-12-G UBPAD-S-12-BG UBPAD-P-12-B	UBNET-12-8-IS UBNET-12-4-IS UBNET-12-6-IS	UBNET-12-4-OS UBNET-12-6-OS	UBNET-12-2-AST UBNET-12-3-AST UBNET-12-4-AST	UBNET-12FG-4 UBNET-12FG-6	UBWC-12-BK	UBWC-12-BL
SIZE 13	UBMAT-13-72-5.5 UBMAT-13-80-5.5 UBMAT-13-80-7	UBPAD-S-13-B	UBNET-13-6-IS UBNET-13-8-IS	UBNET-13-6-OS UBNET-13-8-OS	UBNET-13-2-ASTR UBNET-13-3-AST UBNET-13-4-AST	UBNET-13FG-6	UBWC-13	
SIZE 14	UBMAT-14-72-5.5 UBMAT-14-72-7 UBMAT-14-80-5.5 UBMAT-14-80-7 UBMAT-14-84-7	UBPAD-S-14-B UBPAD-S-14-G UBPAD-S-14-BG UBPAD-P-14-B	UBNET-14-4-IS UBNET-14-6-IS UBNET-14-8-IS	UBNET-14-6-OS UBNET-14-8-OS	UBNET-14-3-AST UBNET-14-4-AST	UBNET-14FG-4 UBNET-14FG-6	UBWC-14-BK	UBWC-14-BL
SIZE 15	UBMAT-15-84-6.5 UBMAT-15-90-7 UBMAT-15-96-7	UBPAD-S-15-B UBPAD-S-15-G UBPAD-S-15-BG UBPAD-P-15-B	UBNET-15-6-IS UBNET-15-8-IS	UBNET-15-6-OS UBNET-15-8-OS	UBNET-15-3-AST UBNET-15-4-AST	UBNET-15FG-5 UBNET-15FG-6 UBNET-15FG-8	UBWC-15-BK	UBWC-15-BL
SIZE 16	UBMAT-16-108-7.5	UBPAD-S-16-B	UBNET-16-6-IS				UBWC-16	
SIZE 17						UBNET-17FG-8		
		Safety Pads Square	Arch Net - Square	Oval Net	Universal Net Type			
	Square Mat	UBPADSQ-13	UBNETSQ-1313-4	UBNETO-1614 UBNETO-1715	UBNETFU1 UBNETFU2			
	Oval Mats							
	Band Mats	Safety Pads Oval						
		UBPADO-1614						
		UBPADO-1715						
	OTHER TYPE							
		UBMATSQ-13						
		UBMATO-1614-96-7 UBMATO-1715-96-7						
		UB-BMAT-1273 UB-BMAT-1378 UB-BMAT-1484 UB-BMAT-1590						

Other Accessories :

Ladder	UBL3S-42-G
Ladder with Flat Steps	UBLBFS3-42
Trampoline Shoe Bag	UBSHB-3
Trampoline Anchor Kit (Set of 4)	UBHWD-AK-4
Deep Fastening Spiraled Anchor Kit - Set Of 4	UBHWD-AKB-4
Trampoline Spring Pull Tool (T-Hook)	UBHWD-TH
Upper bounce® Trampoline Jumping Skate	UB-TJB



Still have questions?

While we provide a large variety of trampolines, we also pride ourselves in the large selection of our trampoline replacement parts which are compatible with most trampolines regardless of their brand.

If you have difficulty finding the correct replacement part for your trampoline, Please give us a call : **1-888-965-3331** or email us at : **support@upperbounce.com**

Our Customer Service Department staff are trained in the details of all trampolines and will help you find the right part to get you bouncing again.

We never forget our goal... **Get the Upper Bounce!**