



ABOVE GROUND POOL SAND FILTER PUMP 2400GPH

ITEM: 75132



OWNER'S MANUAL AND SAFETY INSTRUCTIONS

SAVE THIS MANUAL: KEEP THIS MANUAL FOR SAFETY WARNINGS, PRECAUTIONS, ASSEMBLY, OPERATING, INSPECTION, MAINTENANCE AND CLEANING PROCEDURES. WRITE THE PRODUCT'S SERIAL NUMBER ON THE BACK OF THE MANUAL NEAR THE ASSEMBLY DIAGRAM (OR MONTH AND YEAR OF PURCHASE IF PRODUCT HAS NO NUMBER).

FOR QUESTIONS PLEASE CALL OUR CUSTOMER SUPPORT: (909) 628 0880 MON-FRI 9AM TO 3PM PST

IMPORTANT SAFETY INFORMATION



GENERAL SAFETY WARNINGS

SERIOUS BODILY INJURY OR DEATH CAN RESULT IF THIS PUMP AND SAND FILTER IS NOT INSTALLED AND USED CORRECTLY. INSTALLERS, POOL OPERATORS AND POOL OWNERS MUST READ THESE WARNINGS AND ALL INSTRUCTIONS BEFORE USING THIS PUMP AND SAND FILTER.

SAFETY

Most states and local codes regulate the construction, installation, and operation of public pools and spas, and the construction of residential pools and spas. It is important to comply with these codes, many of which directly regulate the installation and use of this product. Consult your local building and health codes for more information.

IMPORTANT: Attention Installer: This Installation and User's Guide contains important information about the installation, operation and safe use of this pump and sand filter. This Guide should be given to the owner and/or operator of this equipment.

- The sand filters are designed to work with water temperature $> 0^{\circ}\text{C}$ and $<$ than $45\ 0^{\circ}\text{C}$. The filter should never be operated outside of these temperatures or damage may occur. The installation should be carried out in accordance to the safety instructions of swimming pools and the specific instructions for each facility.
- A pool or spa pump must be installed by a qualified pool and spa service professional in accordance with the National Electrical Code and all applicable local codes and ordinances. Improper installation may create an electrical hazard which could result in death or serious injury to pool users, installers, or others due to electrical shock, and may also cause damage to property
- To reduce the risk of injury, do not permit children to use or operate this pump and sand filter.
- **DO NOT** store chemicals around your pool. Chemical spills and fumes can weaken swimming pools and/or spas.
- Any modifications of this equipment of the filter requires prior consent from the supplier's original replacement and accessories authorized by the manufacturer to ensure a high level of safety. The supplier assumes no liability for any damage or injuries caused by unauthorized replacement parts and/or accessories. In the even of defective operation or fault, contact the supplier or the nearest authorized service agent.
- When setting up pool water turnovers or flow rates the operator must consider local codes governing turnover as well as disinfectant feed ratios
- **DO NOT** increase pump size; this may increase the flow rate through the system and exceed the maximum flow rate stated on the drain cover.
- Pumps improperly sized or installed or used in applications other than for which the pump was intended can result in serious personal injury or death. These risks may include but not be limited to electric shock, fire, flooding, suction entrapment or serious injury or property damage caused by a structural failure of the pump or other system component

IMPORTANT SAFETY INFORMATION

HIGH PRESSURE FROM THE SAND FILTER CAN CAUSE SEVERE INJURY OR MAJOR PROPERTY DAMAGE DUE TO TANK SEPARATION. RELEASE ALL PRESSURE AND READ INSTRUCTIONS BEFORE WORKING ON THE SAND FILTER. IF THE FILTER CLAMP IS ADJUSTED UNDER PRESSURE, THE TANK CAN SEPARATE, CAUSING SERIOUS INJURY OR MAJOR PROPERTY DAMAGE.

PUMPS REQUIRE HIGH VOLTAGE WHICH CAN SHOCK, BURN, OR CAUSE DEATH. BEFORE WORKING ON PUMP! ALWAYS DISCONNECT POWER TO THE POOL PUMP AT THE CIRCUIT BREAKER BEFORE SERVICING THE PUMP. FAILURE TO DO SO COULD RESULT IN DEATH OR SERIOUS INJURY TO SERVICE PERSON, POOL USERS OR OTHERS DUE TO ELECTRIC SHOCK.



POOL AND SPA PUMPS MOVE LARGE VOLUMES OF WATER, WHICH CAN POSE EXTREME DANGER IF A PERSON'S HAIR COMES IN PROXIMITY TO A DRAIN THAT IS NOT THE PROPER SIZE FOR THE PUMP OR PUMPS.

The Virginia Graeme Baker Pool and Spa Safety Act imposes certain new requirements on owners and operators of swimming pools and spas. Pools or spas constructed on or after December 20, 2008, shall utilize:

- (A) No submerged suction outlets, a gravity drainage system with ASME/ANSI cover(s), one or more unblock-able outlets; or
- (B) A multiple main drain system without isolation capability with suction outlet covers that meet ASME/ANSI A112.19.8 Suction Fittings for Use in Swimming Pools, Wading Pools, Spas, and Hot Tubs and either:
 - (i) A safety vacuum release system (SVRS) meeting ASME/ANSI A112.19.17 Manufactured Safety Vacuum Release Systems (SVRS) for Residential and Commercial Swimming Pool, Spa, Hot Tub, and Wading Pool Suction Systems and/or ASTM F2387 Standard Specification for Manufactured Safety Vacuum Release Systems (SVRS) for Swimming Pools, Spas and Hot Tubs or
 - (ii) A properly designed and tested suction-limiting vent system or
 - (iii) An automatic pump shut-off system.

Pools and spas constructed prior to December 20, 2008, with a single submerged suction outlet shall use a suction outlet cover that meets ASME/ANSI A112.19.8 and either:

- (A) A multiple main drain system without isolation capability, or
- (B) A safety vacuum release system (SVRS) meeting ASME/ANSI A112.19.17 and/or ASTM F2387, or
- (C) A properly designed and tested suction-limiting vent system, or
- (D) An automatic pump shut-off system, or
- (E) Disabled submerged outlets, or
- (F) Suction outlets shall be reconfigured into return inlets.

IMPORTANT SAFETY INFORMATION

This filter operates under high pressure. When any part of the circulating system (e.g., clamp, pump, filter, valves, etc.) is serviced, air can enter the system and become pressurized. Pressurized air can cause the lid or control valve to separate which may result in serious injury, death, or property damage. To avoid this potential hazard, follow these instructions.

1. Before repositioning valves and before beginning the assembly, disassembly, or adjustment of the clamp or any other service of the circulating system:
 - (a) Turn the pump off and shut off any automatic controls to ensure the system is not inadvertently started during the servicing;
 - (b) Open manual air relief valve;
 - (c) Wait until all pressure is relieved, pressure gauge must read zero (0).
2. Whenever installing the filter clamp, follow the filter valve and clamp installation instructions exactly.
3. Once service on the circulating system is complete, follow system restart instructions exactly.
4. Maintain circulation system properly. Replace worn or damaged parts immediately (e.g., clamp, pressure gauge, relief valve, o-rings, etc.).
5. Be sure that the filter is properly mounted and positioned according to instructions provided.



Failure to operate your filter system or inadequate filtration can cause poor water clarity obstructing visibility in your pool and can allow diving into or on top of obscured objects, which can cause serious personal injury or drowning.

This filter operates under pressure. With the valve clamped properly and operated without air in the system, this filter will operate in a safe manner. Air entering the filter and the valve not clamped correctly can cause the valve to separate, which could cause serious personal injury and/or property damage.

Always turn pump off before changing valve positions. Changing valve positions while the pump is running can damage the control valve, which may cause serious injury or property damage.

Chemical fumes and/or spills can cause serious corrosion to the filter and pump structural components. Structurally weakened components can cause filter, pump or valve attachments to separate and could cause serious bodily injury or property damage.

High voltage can cause serious or fatal injury. Always install a suitable GFCI at the power source of this unit as an added safety precaution. Article 681-31 of the NEC requires that a GFCI be used if this pump is used with a storable pool.

Never work on the pump while it is running or power is still connected. High voltage can cause serious or fatal injury. A suitable ground fault interrupter should always be installed at the power supply source of this unit. Be sure to ground the motor before connecting to electrical AC power supply. Failure to ground the motor can cause serious or fatal electrical shock hazard. DO NOT ground to a gas supply pipe line.

FOR CORD AND PLUG CONNECTED UNITS: Connect only to a ground type receptacle protected by a Ground Fault Circuit Interrupter (GFCI). Contact a qualified electrician if you cannot verify that the receptacle is protected by GFCI. Do Not Bury Cord. Locate cord to minimize abuse from lawn mowers, hedge trimmers, and other equipment. To reduce the risk of electrical shock, replace damaged cord immediately. To reduce the risk of electrical shock, Do Not Use an extension cord to connect unit to electrical supply; provide a properly located outlet.

IMPORTANT SAFETY INFORMATION

CAUTION

Always turn pump off before changing valve positions. Changing valve positions while the pump is running can damage the control valve, which may cause serious injury or property damage.

Allowing water to freeze in the system will damage the system and cause potential water damage/ flooding and potential property damage.

INSTALLATION

SAND FILTRATION WORKING PRINCIPLE

Incoming water from the piping system is automatically directed by the multi-port valve to the top of the filter bed. As the water is pumped through the filter sand, dirt and debris are trapped by the filter bed, and filtered out. The filter water is returned from the bottom of the filter tank., through the multi-port and back through the piping system .

PREPARATION BEFORE INSTALLATION

1. Position the filter as close to the swimming pool / spa as possible.
2. The filter should be placed on a level, concrete slab, firm ground or equivalent.
3. Position the filter near piping so that it is convenient for operating and servicing.
4. Ensure that the compliance label is facing front to allow easy identification.

1. Pump needs screw and cover to install on the filter drain.

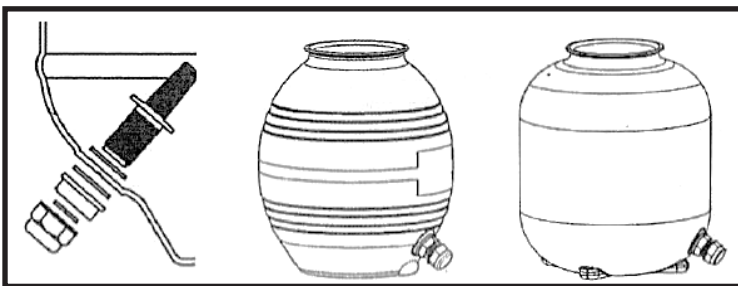

2. Press and turn the sand tank to mount it to the sand filter support with correct direction, drain plug on the outside (see below)

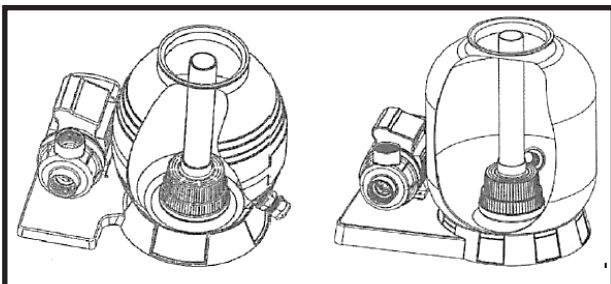

INSTALLATION

3. Insert the tube with diffuser body inside the tank as above picture shows, then place the funnel on the tank's mouth and out the quartz sand into the tank. A 12" sand filter requires about 19kg of sand to fill the tank, a 14" sand filler needs about 27kg of sand to fill the tank.

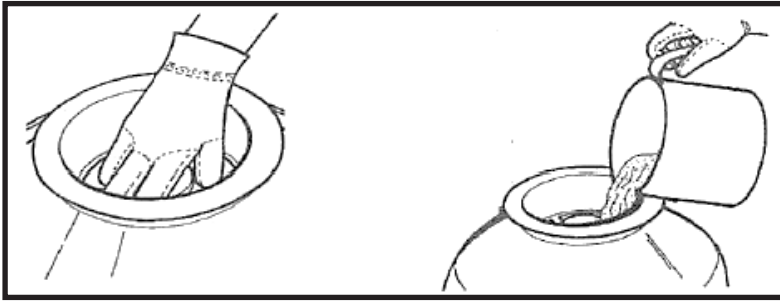

4. Remove the funnel and make sure the tank's neck is clean. Put the O-ring on the valve and use clamp to fix the valve with the tank. Pump port valve direction needs to face pump's out-port.

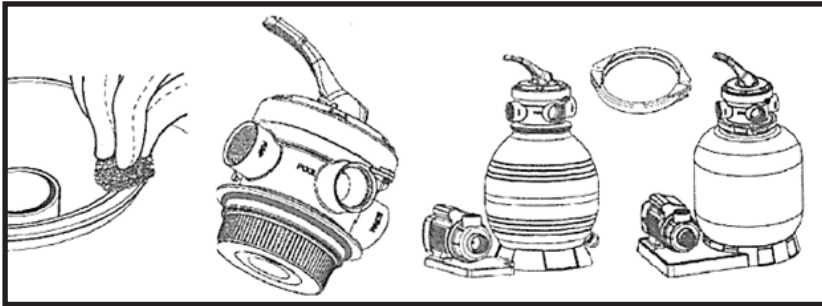

5. Connect the sand tank to the pump with hose and hose adapters.

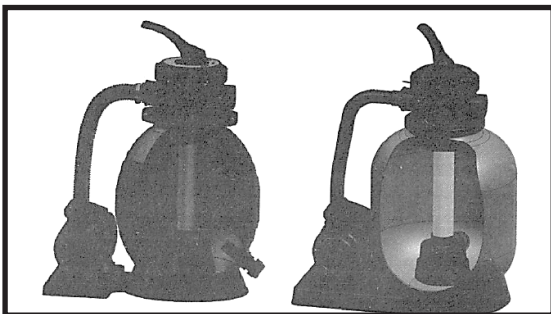

INSTALLATION NOTES:

- Make sure the filter has worked under work pressure and using a pressure control valve when the system is using a booster pump.
- If the pump position is higher than the water level, it requires installation of the back water control valve.
- If the pump position is higher than the water level, it requires installing an isolation valve. It can stop the water return back when doing the general inspection.
- Reduce the connection adapters and hose connection, bending as little as possible. Decreasing the water flow scrub can reach the maximum effectiveness
- Ensure solvents are not excessively applied to the fitting as this can run onto the O-ring and create sealing issues.
- Do not over tighten fittings or adapters.

INSTALLATION

HOW TO USE:

1. Inspect all connections have been made and are secure.
2. Depress the top mount valve handle and rotate to **BACKWASH** position.
3. Prime and start pump according to the pump instructions.

NOTE:

All suction and discharge valves must be opened when starting the system. Failure to do so can cause severe personal injury. Make sure the filter vessel are full. Fill the water before start-up the pump. Failure to do so can cause damage to the pump.

4. Once water flows steadily out of the waste line, run the pump for at least 2 minutes. The initial back-washing of the filter is recommended to remove any impurities of fine sand.
5. Turn the pump off and set the valve to **RINSE** position. Start the pump and operate until water in the sight window is clear. Turn the pump off and set the valve to the **FILTER** position and restart the pump. Your filter is now operating in the normal filter mode, filtering particles from the pool water.

1. NOTE: The initial pressure gauge reading when the filter is clean. As the filter removes the dirt and debris, the accumulation in the filter will cause the pressure to rise and flow to diminish. When the pressure gauge reading is 8-10 PSI (0.55 - 0.69 BAR) higher than the initial "clean" pressure you noted, it is time to backwash the filter.

2. IMPORTANT: To prevent unnecessary strain on the piping system and valving, always shut off the pump before switching the filter control valve position.

To prevent damage to the pump and filter and for proper operation of the system, clean the pump strainer and skimmer baskets regularly.

FILTER CONTROL VALVE FUNCTIONS

FILTER: Set valve to filter for normal filtering. Also use for regular vacuuming.

BACKWASH: For cleaning the filter. When the filter pressure gauge rises 8-10 PSI (0.55 - 0.69 BAR) above start-up. Clean Pressure: Stop the pump, set valve to **BACKWASH**. Start the pump and backwash until the water in sight window is clear. Approximately 2 minutes or less depending on the dirt accumulation. Proceed to RINSE.

RINSE: After backwashing, with the pump off, set the valve to **RINSE**. Start pump and operate for about 1/2 - 1 minute. This ensures that the dirty water from backwashing is rinsed out of the filter to waste, preventing possible return to the pool. Stop the pump and set the valve to **FILTER** and start pump for normal filtering.

WASTE: To bypass the filter for draining or lowering the water level and for vacuuming heavy debris directly to waste.

PARTS LIST

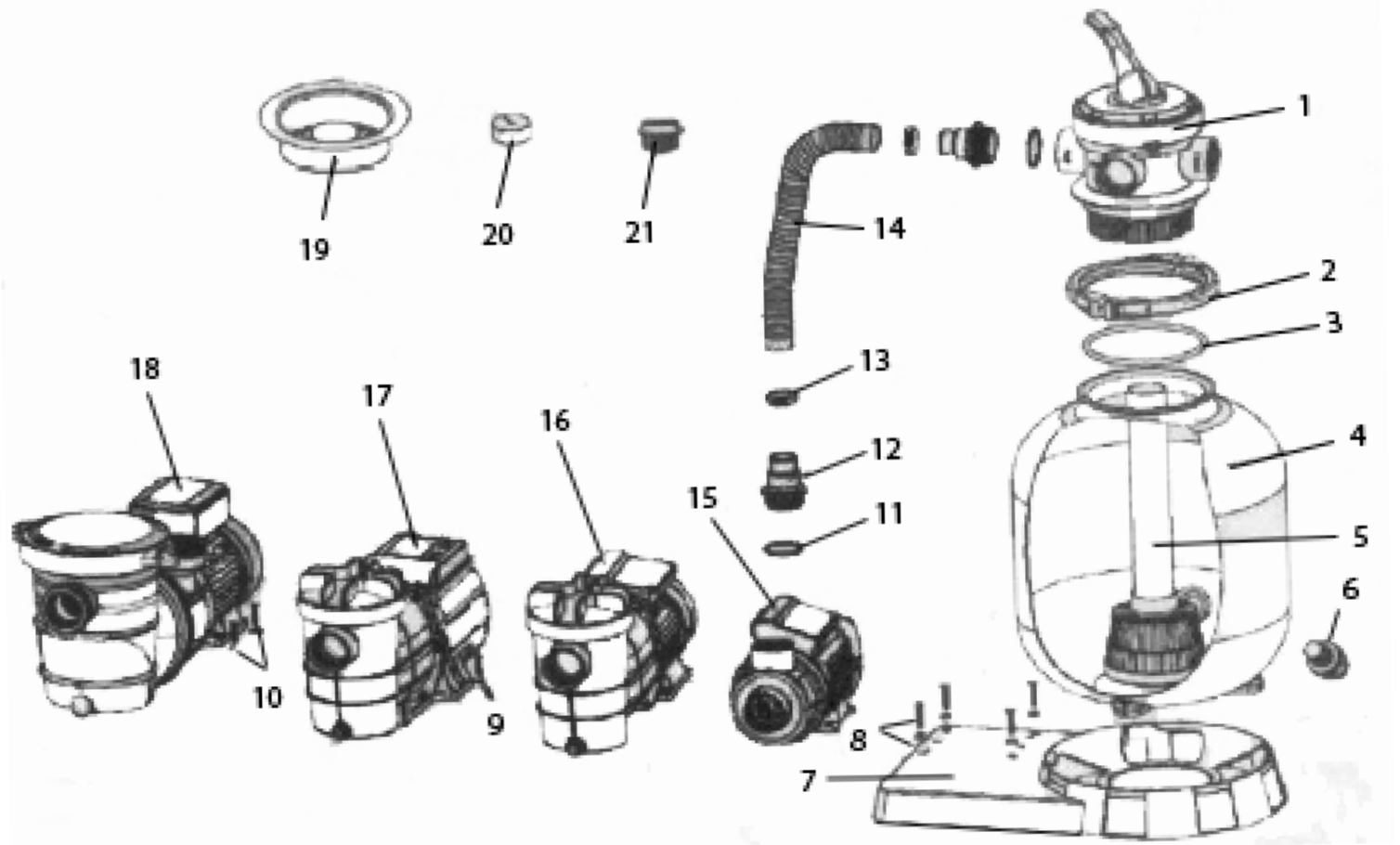

PARTS LIST

#	DESCRIPTION	QTY	#	DESCRIPTION	QTY
1	4-WAY VALVE	1	11	O-RING	5
2	FLANGE CLAMP	1	12	HOSE ADAPTER	5
3	O-RING	1	13	HOSE CLAMP	1
4	FILTER TANK	1	14	1/14" (32mm)x45cm HOSE	1
5	FILTER ASSEMBLY	1	15	0.25HP PUMP	1
6	DRAIN PLUG	1	16	0.35HP PUMP	1
7	SAND FILTER SUPPORT	1	17	.35HP PUMP	1
8	SCREW M6x25 AND NUT M6	4	19	NECK FITTING	1
9	SCREW ST5.5x30 AND NUT 16X 65x1	2	20	PRESSURE GAUGE	1
10	SCREW ST5.5x30 AND NUT 16X 65x1	4	21	PLUG WITH O-RING 1.5" MIP	1

DISCLAIMER

PLEASE READ THE FOLLOWING CAREFULLY

THE MANUFACTURER AND/OR DISTRIBUTOR HAS PROVIDED THE PARTS LIST AND ASSEMBLY DIAGRAM IN THIS MANUAL AS A REFERENCE TOOL ONLY. NEITHER THE MANUFACTURER OR DISTRIBUTOR MAKES ANY REPRESENTATION OR WARRANTY OF ANY KIND TO THE BUYER THAT HE OR SHE IS QUALIFIED TO MAKE ANY REPAIRS TO THE PRODUCT, OR THAT HE OR SHE IS QUALIFIED TO REPLACE ANY PARTS OF THE PRODUCT. IN FACT, THE MANUFACTURER AND/OR DISTRIBUTOR EXPRESSLY STATES THAT ALL REPAIRS AND PARTS REPLACEMENTS SHOULD BE UNDERTAKEN BY CERTIFIED AND LICENSED TECHNICIANS, AND NOT BY THE BUYER. THE BUYER ASSUMES ALL RISK AND LIABILITY ARISING OUT OF HIS OR HER REPAIRS TO THE ORIGINAL PRODUCT OR REPLACEMENT PARTS THERETO, OR ARISING OUT OF HIS OR HER INSTALLATION OF REPLACEMENT PARTS THERETO.

Record Product's Serial Number Here: _____

Note: If product has no serial number, record month and year of purchase instead.

Note: Some parts are listed and shown for illustration purposes only and are not available individually as replacement parts.



SAVE THESE INSTRUCTIONS.

Questions, Problems or Missing Parts?



Before returning to a retailer, our exceptional customer service is available to help.

Call Us: 909.628.0880

Hours of Operation: 9 to 4pm PST, Monday - Friday

Email: customer@xtremepowerusa.com

PRODUCT MADE IN CHINA