

ASSEMBLY INSTRUCTIONS

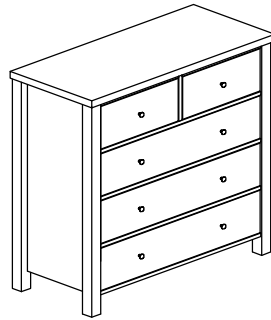

**IMPORTANT
PLEASE READ BEFORE YOU CONTINUE FURTHER**

WARNING AND INSTRUCTIONS

- PLEASE KEEP THE ORIGINAL PACKAGING UNTIL THE ITEM IS FULLY ASSEMBLED AND IN PLACE. IN THE UNLIKELY EVENT THAT YOU NEED TO RETURN YOUR PRODUCT, IT MUST BE RETURNED IN ITS ORIGINAL PACKAGING TO AVOID FURTHER DAMAGE. FAILURE TO COMPLY TO THESE PROCEDURES, NO RETURN'S WILL BE ACCEPTED.
- IMPORTANT: RETAIN THESE INSTRUCTIONS FOR FUTURE REFERENCE.
- DUE TO THE SIZE OF THIS PRODUCT WE RECOMMEND THAT IT IS ASSEMBLED IN THE ROOM INTENDED FOR USE.
- WHEN YOU ARE READY TO START, MAKE SURE THAT YOU HAVE THE RIGHT TOOLS, PLENTY OF SPACE AND A CLEAN, DRY AREA FOR ASSEMBLY.
- UNWRAP ALL PACKAGING MATERIALS AND PLACE THE COMPONENTS ON TOP OF THE CARTON BOX OR ON A CLEAN FLOOR TO PREVENT IT FROM SCRATCHING.
- CHECK THE PACK AND MAKE SURE YOU HAVE ALL THE PARTS LISTED.
- ENSURE THAT THIS PRODUCT IS FULLY ASSEMBLED AS ILLUSTRATED BEFORE USE.
- TOOLS NOT INCLUDED.
- CHECK ALL SCREWS OR BOLTS ARE TIGHTENED AND INSPECT REGULARLY.
- THIS PRODUCT SHOULD ONLY BE USED ON FIRM LEVEL GROUND.
- KEEP SMALL PART OUT OF REACH OF CHILDREN.
- MAKE SURE THE LEGS REMAIN IN CONTACT WITH THE GROUND.
- DO NOT USE POWER TOOLS TO CONSTRUCT THIS PRODUCT.
- DO NOT TIGHTENED SCREWS UNTIL FULLY ASSEMBLED.
- DO NOT OVER TIGHTENED SCREWS OR BOLTS.
- DO NOT USE THIS PRODUCT IF PARTS ARE MISSING, DAMAGE OR WORN.
- DO NOT SIT AND STAND ON THE PRODUCT.
- TO CLEAN WIPE WITH A SPONGE AND WARM SOAPY WATER. DO NOT USE SOLVENT BASED CLEANERS OR DETERGENTS AS THEY CAN BLEACH OR DAMAGE THE PRODUCT.
- NEVER USE SCOURERS, ABRASIVES OR CHEMICAL CLEANERS.

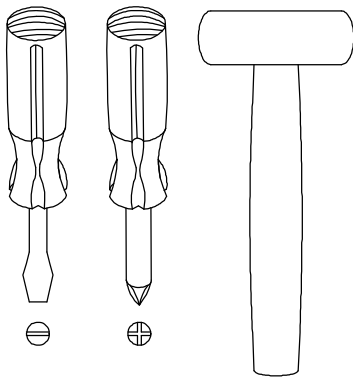

(Tools not provided)

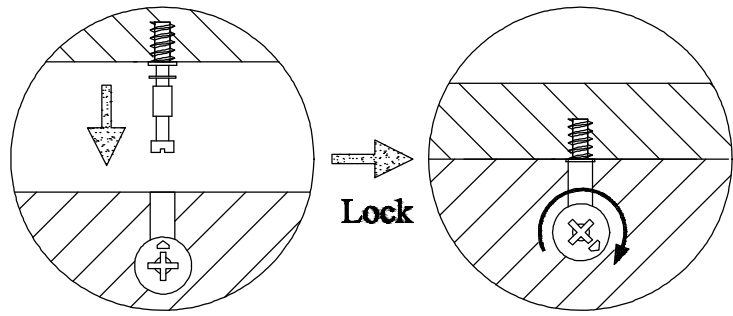

Use a flat blade screwdriver to tighten the cam nuts. A quarter turn clockwise is all that is needed.

This is how a cam nut works.....

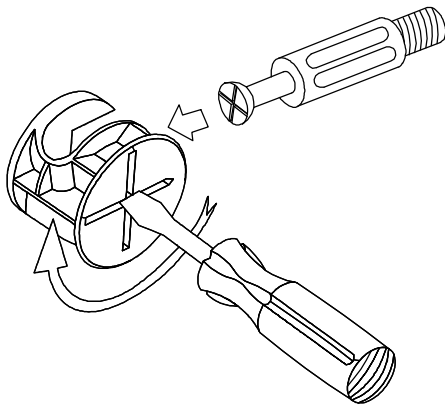

The head of the cam bolt goes into the open mouth of the cam nut. You then turn the cam nut so it tightens over the bolt.

TWO PERSONS REQUIRED TO ASSEMBLE THIS PRODUCT

- 1. Please check that you have all the parts listed before you start assembling. If you do find that something is missing, do not continue assembly. Please contact your supplier immediately.**
- 2. Lay out all of the components on a soft surface as if you were preparing to do a jigsaw puzzle.**
- 3. Separate and identify each component from the hardware pack and rest each one in its proper location before fastening.**

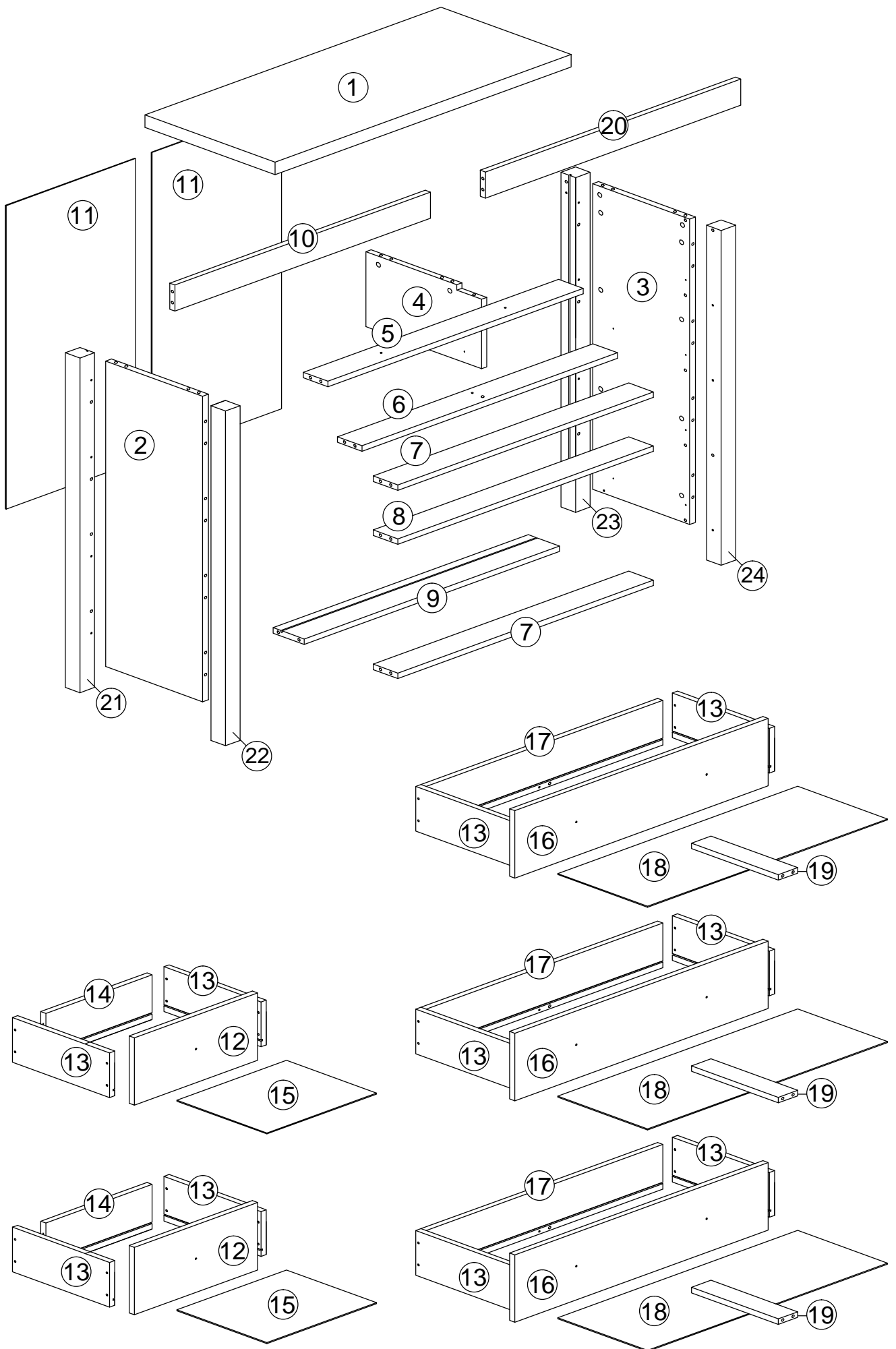

















THE USE OF POWER TOOLS TO ASSEMBLE THIS PRODUCT WILL INVALIDATE ANY CLAIM AND MAY DAMAGE THIS PRODUCT MAKING IT UNSAFE.

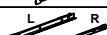

PARTS LIST

NO.	PARTS					QTY
1	900	X	400	X	30	1 PC
2	888	X	300	X	18	1 PC
3	888	X	300	X	18	1 PC
4	346	X	218	X	15	1 PC
5	768	X	76	X	15	1 PC
6	768	X	76	X	15	1 PC
7	768	X	76	X	15	2 PCS
8	768	X	76	X	15	1 PC
9	768	X	96	X	15	1 PC
10	768	X	76	X	15	1 PC
11	882	X	388	X	2.5	2 PCS
12	370	X	196	X	15	2 PCS
13	300	X	130	X	15	10 PCS
14	319	X	130	X	15	2 PCS
15	328	X	278	X	2.5	2 PCS
16	762	X	196	X	15	3 PCS
17	711	X	130	X	15	3 PCS
18	720	X	278	X	2.5	3 PCS
19	268	X	60	X	15	3 PCS
20	768	X	76	X	15	1 PC
21	973	X	45	X	45	1 PC
22	973	X	45	X	45	1 PC
23	973	X	45	X	45	1 PC
24	973	X	45	X	45	1 PC

HARDWARE LIST

NO.	DESCRIPTION	QTY
A	 WOOD DOWEL M8 x 25MM	34
B	 CAM NUT	40
C	 CAM BOLT	40
D	 CAM CAP	40
E	 CB SCREW M3.5 x 16MM	38
F	 CB SCREW M4 x 38MM	42
G	 CSK CAP WOOD M6 x 40MM	3
H	 HANDLE ZH-1609.NH	8
I	 HANDLE SCREW M4 x 38MM	8
J	 ALLEY KEY M4	1
K	 PVC NAIL WITH PIN 5/8	4
L	 PVC CORNER L BRACKET	4
M	 DRAWER SLIDE 12"	10
N	 DRAWER SLIDE 12"	10
O	 PVH 3MM - 871MM	1
P	 EURO SCREW 5 X 8	20
Q	 FURNITURE GLUE (10G)	1
R	 WOOD DOWEL M8 X 40MM	16

THE USE OF POWER TOOLS TO ASSEMBLE THIS PRODUCT WILL INVALIDATE ANY CLAIM AND MAY DAMAGE THIS PRODUCT MAKING IT UNSAFE.



STEP 1

A	 WOOD DOWEL M8 x 25MM	34
---	--	----

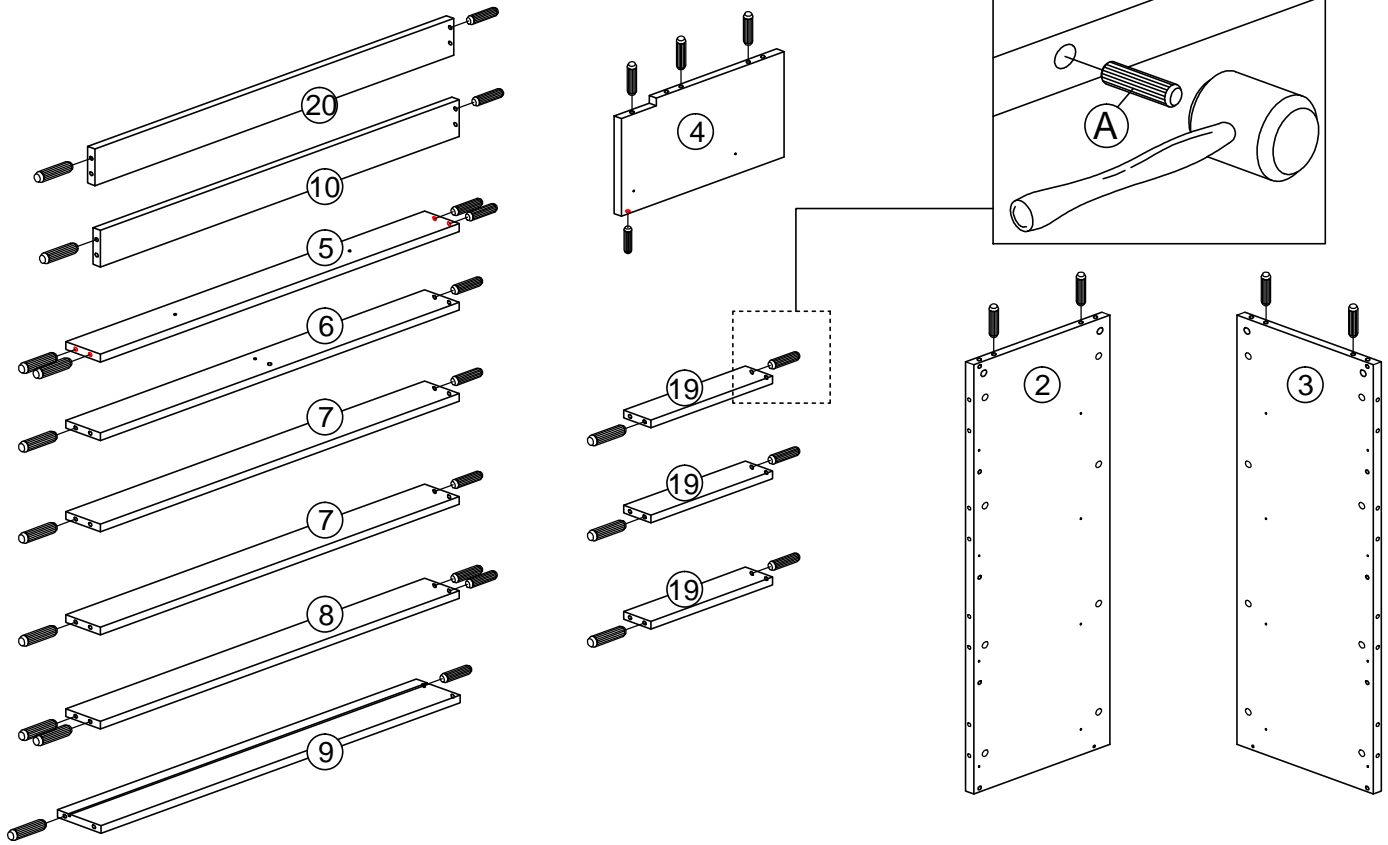

STEP 2



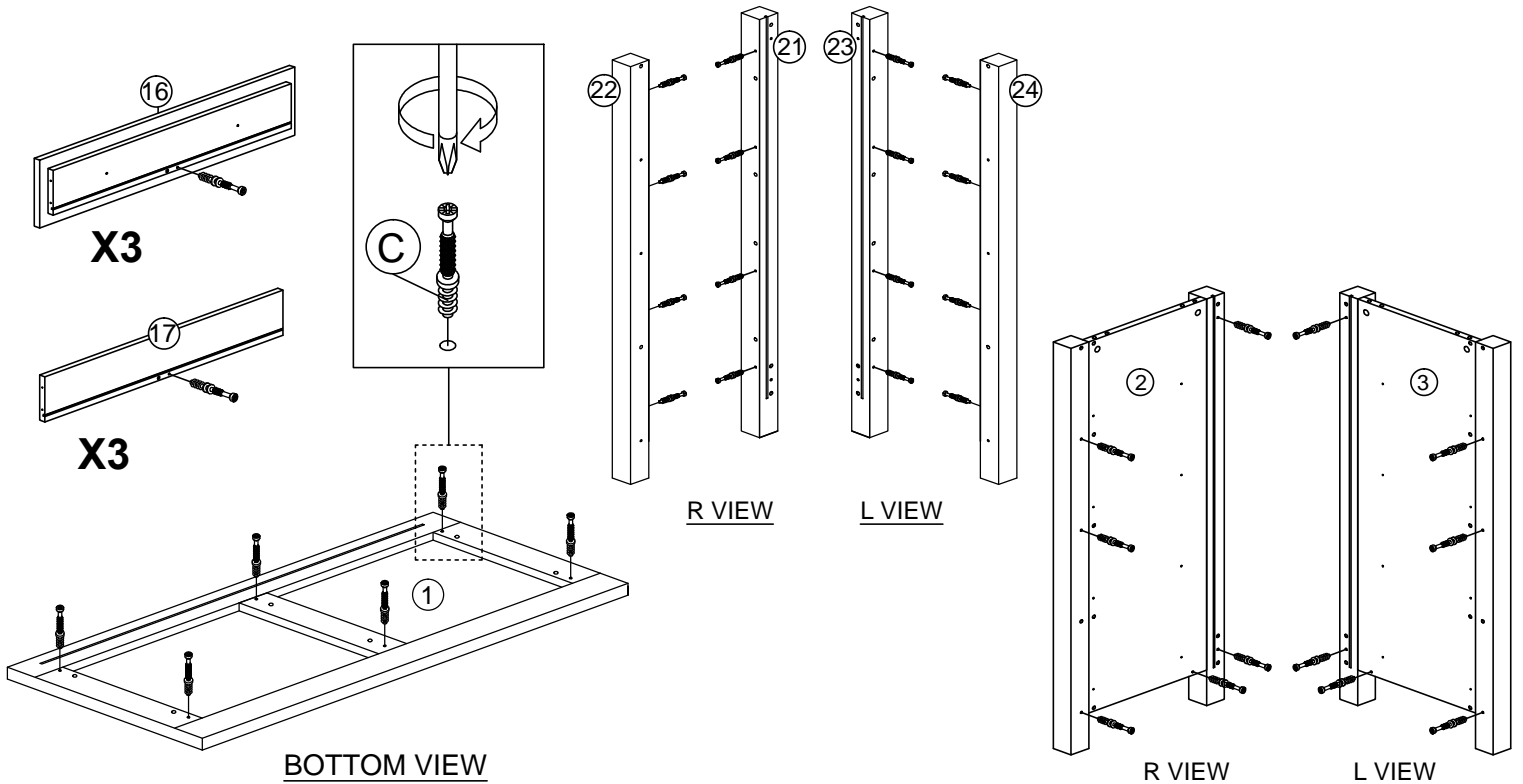

C	 CAM BOLT	40
---	--	----



THE USE OF POWER TOOLS TO ASSEMBLE THIS PRODUCT WILL INVALIDATE ANY CLAIM AND MAY DAMAGE THIS PRODUCT MAKING IT UNSAFE.



STEP 3

B		CAM NUT	16
D		CAM CAP	16
J		ALLEN KEY M4	1
R		WOOD DOWEL M8 x 40MM	16
Q		FURNITURE GLUE (10G)	1

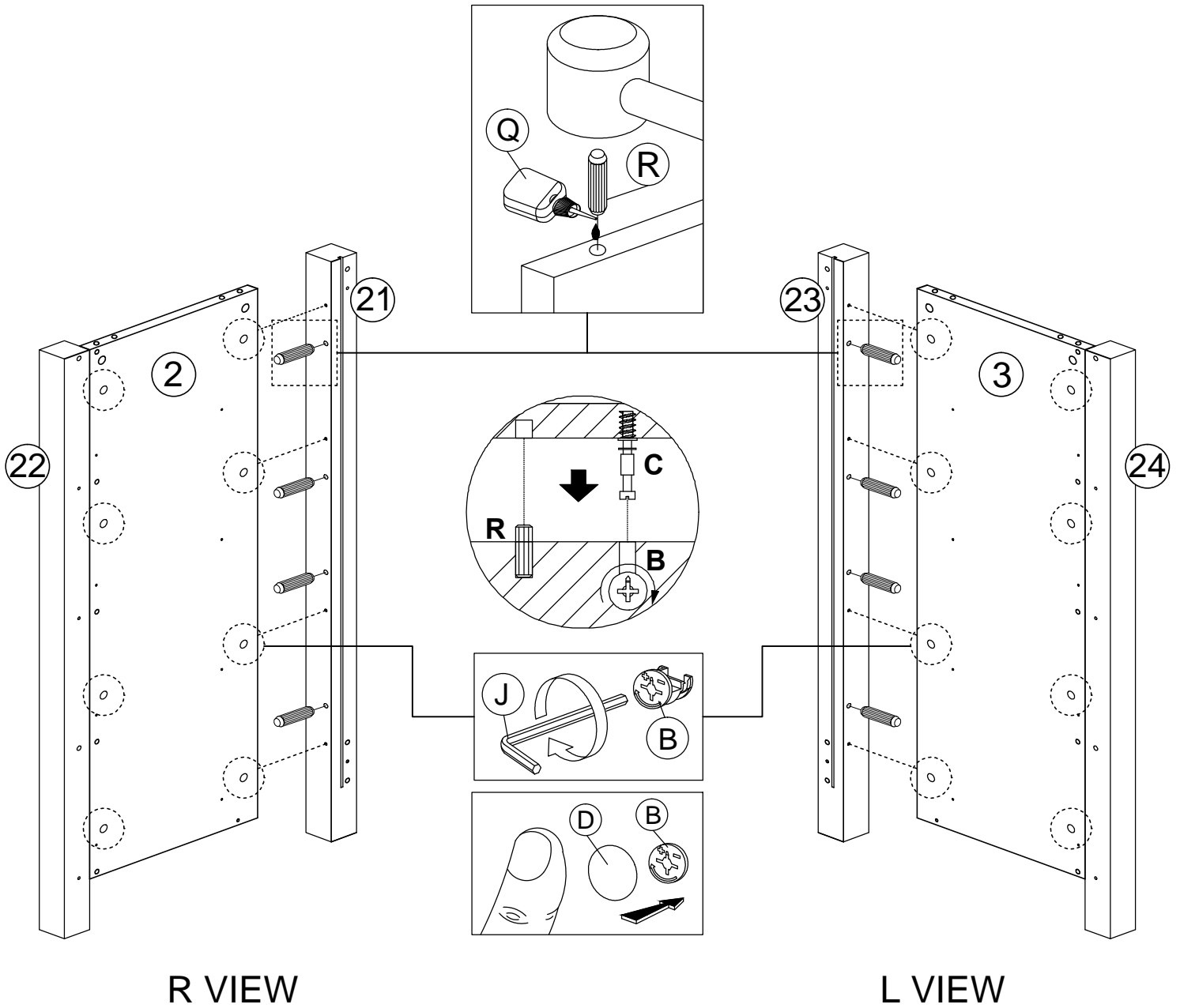

THE USE OF POWER TOOLS TO ASSEMBLE THIS PRODUCT WILL INVALIDATE ANY CLAIM AND MAY DAMAGE THIS PRODUCT MAKING IT UNSAFE.



STEP 4



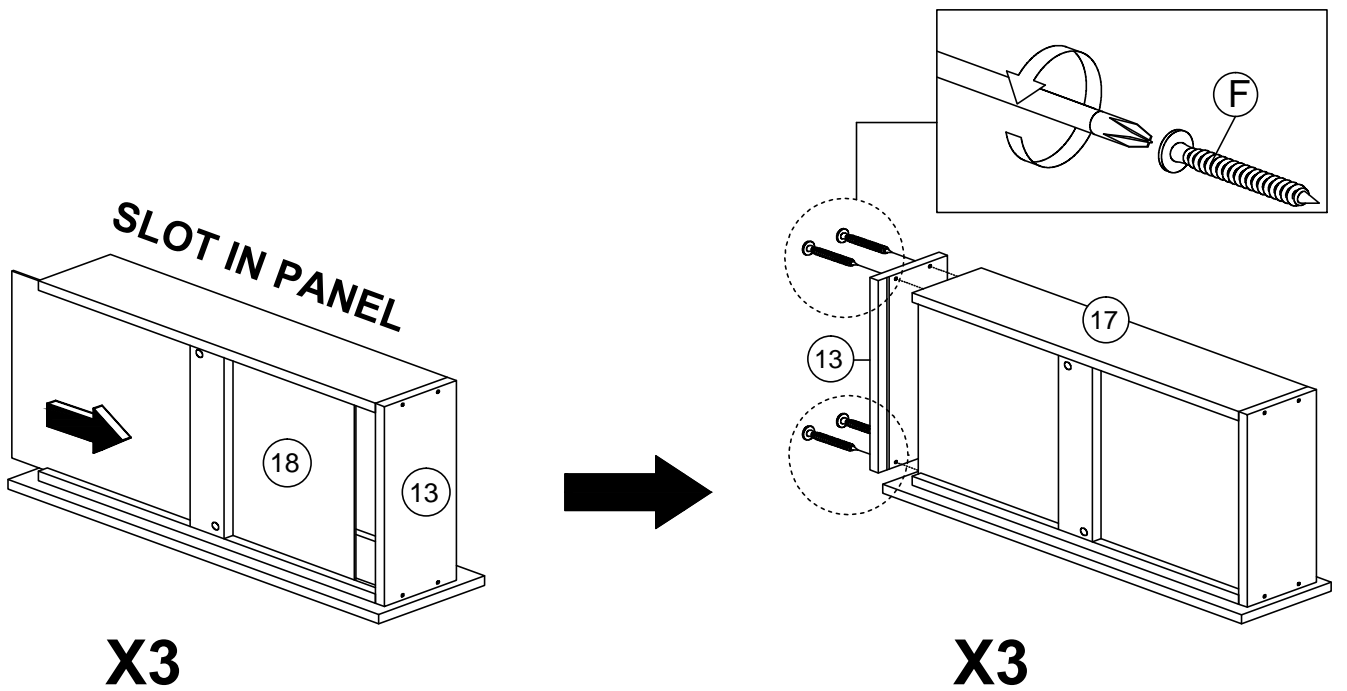
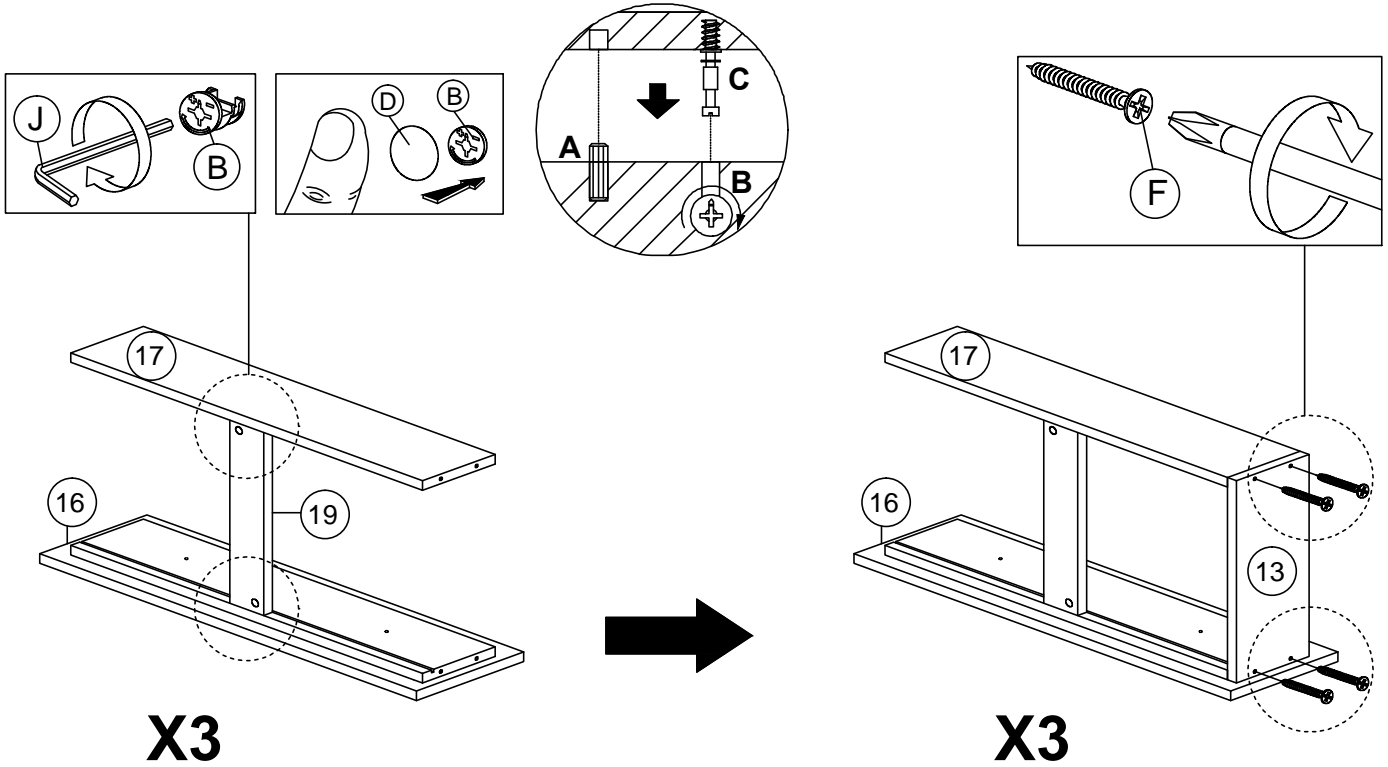

B		CAM NUT	6
D		CAM CAP	6
F		CB SCREW M4 x 38MM	24
J		ALLEN KEY M4	1



THE USE OF POWER TOOLS TO ASSEMBLE THIS PRODUCT WILL INVALIDATE ANY CLAIM AND MAY DAMAGE THIS PRODUCT MAKING IT UNSAFE.



STEP 5

E		CB SCREW M3.5 x 16MM	18
H		HANDLE ZH-1609.NH	6
I		HANDLE SCREW M4 x 38MM	6
N		DRAWER SLIDE 12"	6

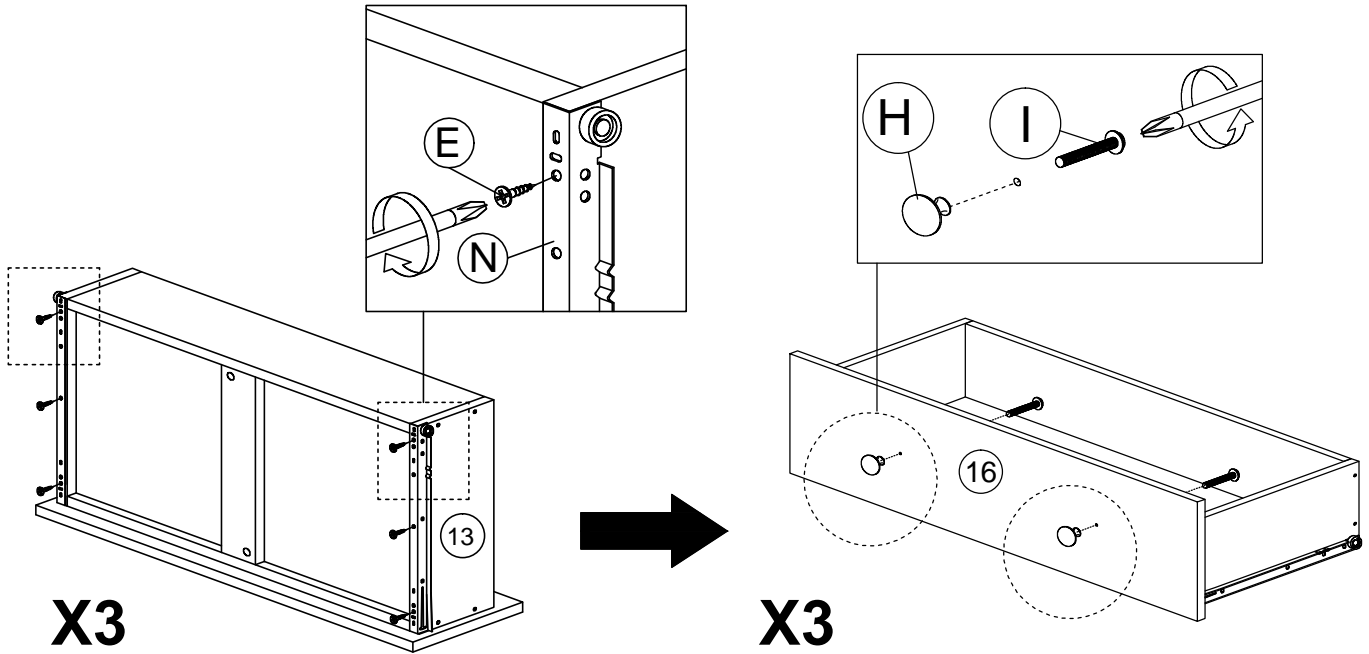

STEP 6



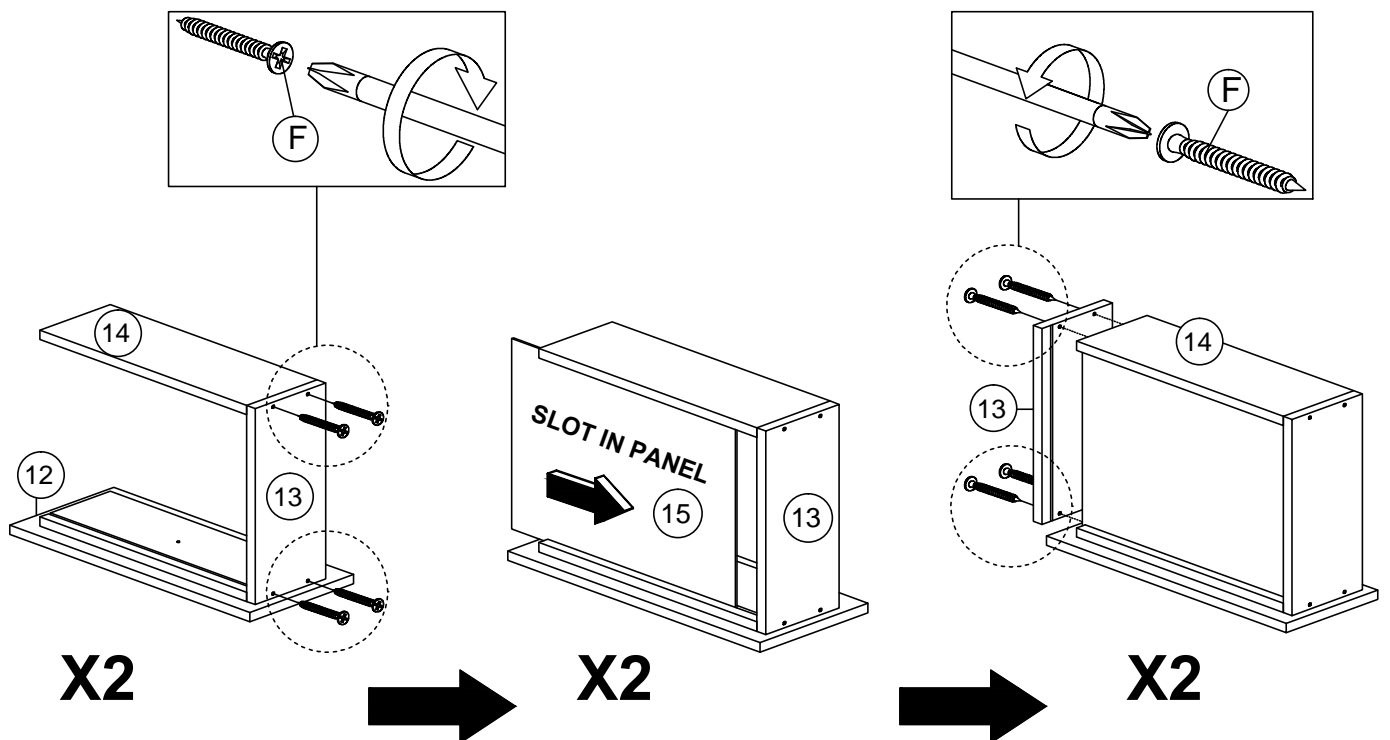

F		CB SCREW M4 x 38MM	16
---	---	--------------------	----



THE USE OF POWER TOOLS TO ASSEMBLE THIS PRODUCT WILL INVALIDATE ANY CLAIM AND MAY DAMAGE THIS PRODUCT MAKING IT UNSAFE.



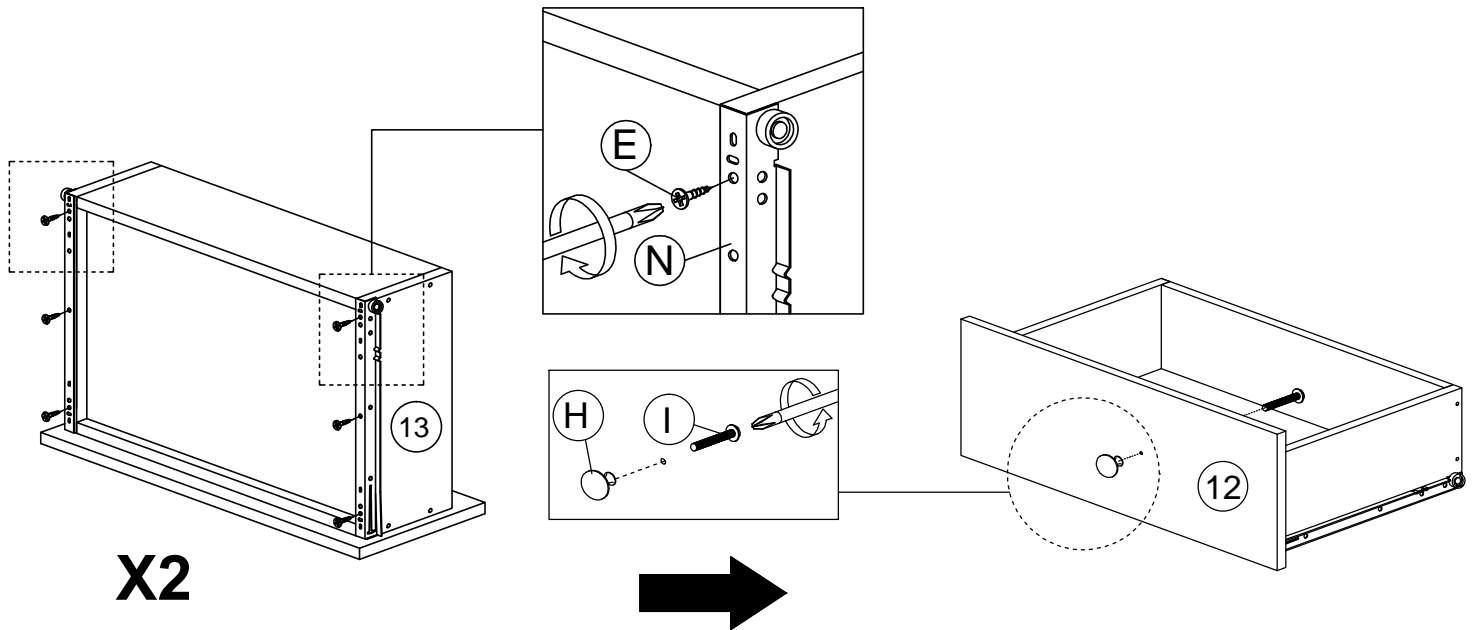

STEP 7

E		CB SCREW M3.5 x 16MM	12
H		HANDLE ZH-1609.NH	2
I		HANDLE SCREW M4 x 38MM	2
N		DRAWER SLIDE 12"	4



X2

STEP 8

P		EURO SCREW 5X8MM	20
M		DRAWER SLIDE 12"	10

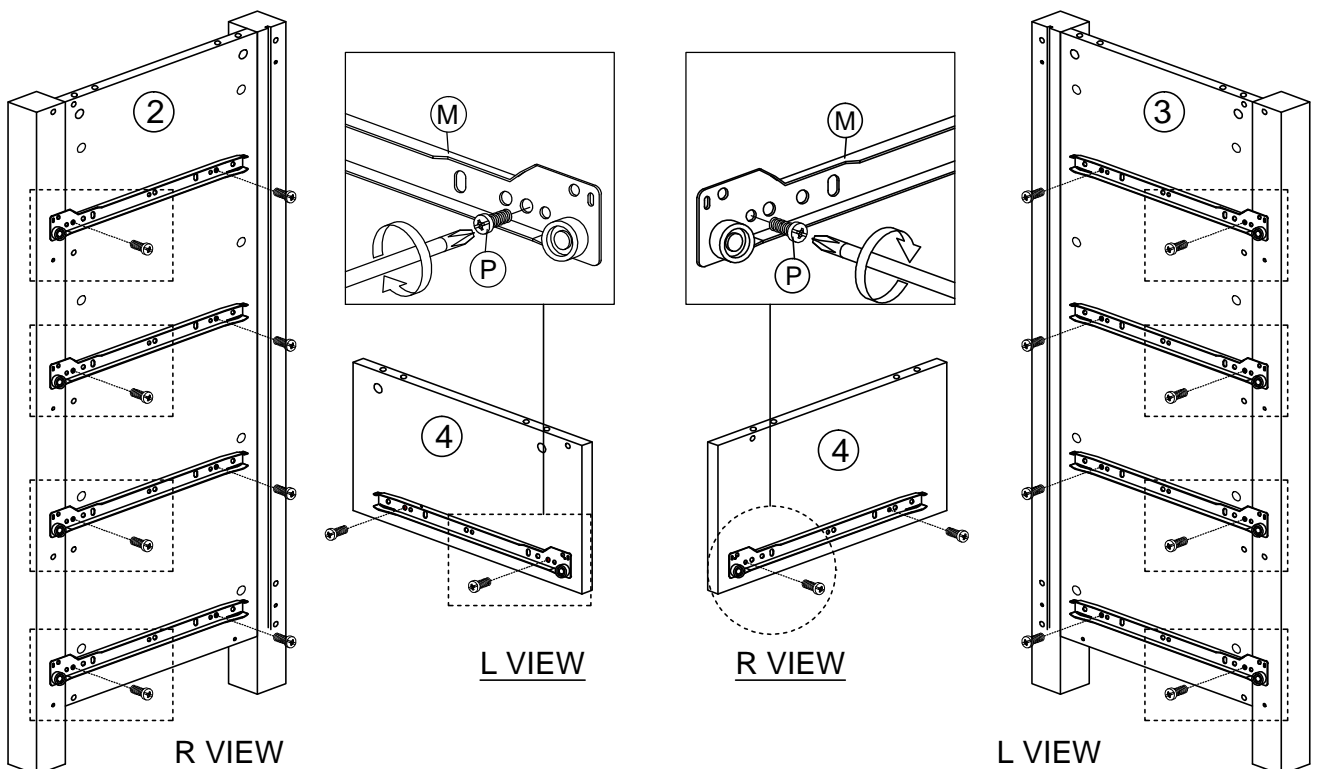

R VIEW

L VIEW



R VIEW

L VIEW

THE USE OF POWER TOOLS TO ASSEMBLE THIS PRODUCT WILL INVALIDATE ANY CLAIM AND MAY DAMAGE THIS PRODUCT MAKING IT UNSAFE.



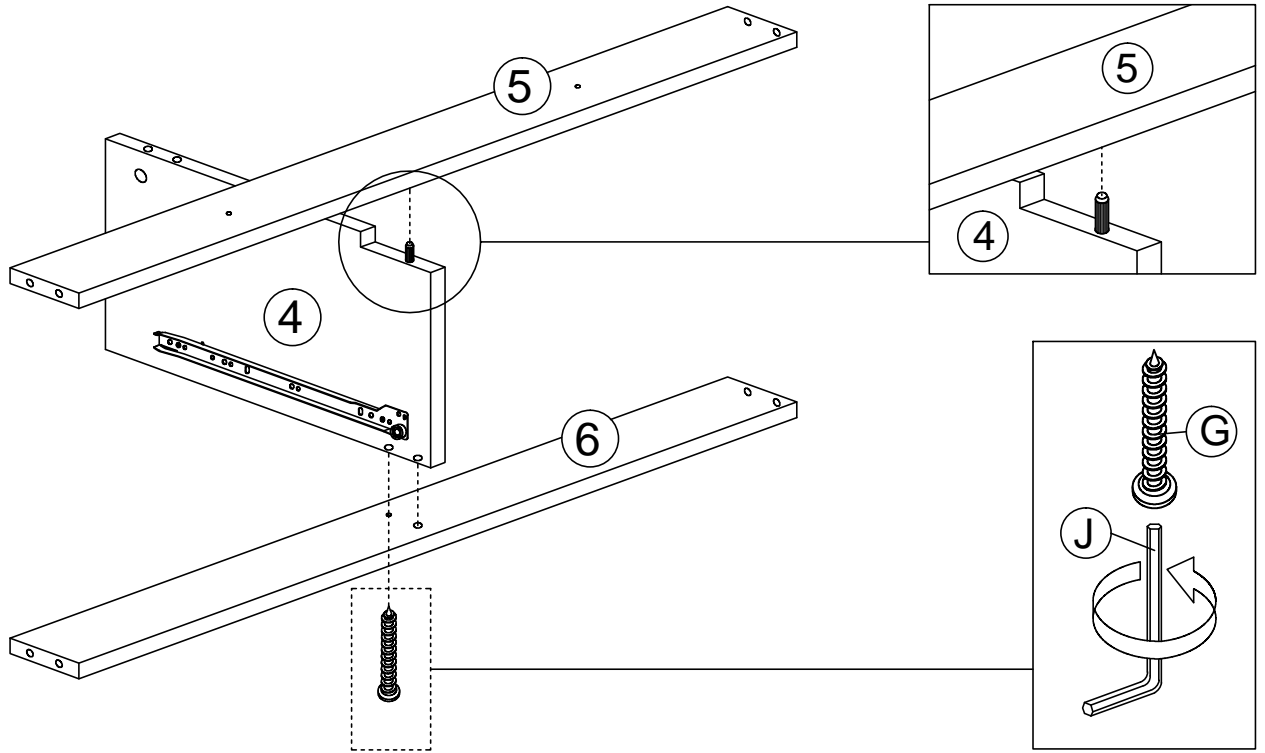

STEP 9

G		CSK CAP WOOD M6 x 40MM	1
J		ALLEN KEY M4	1



STEP 10



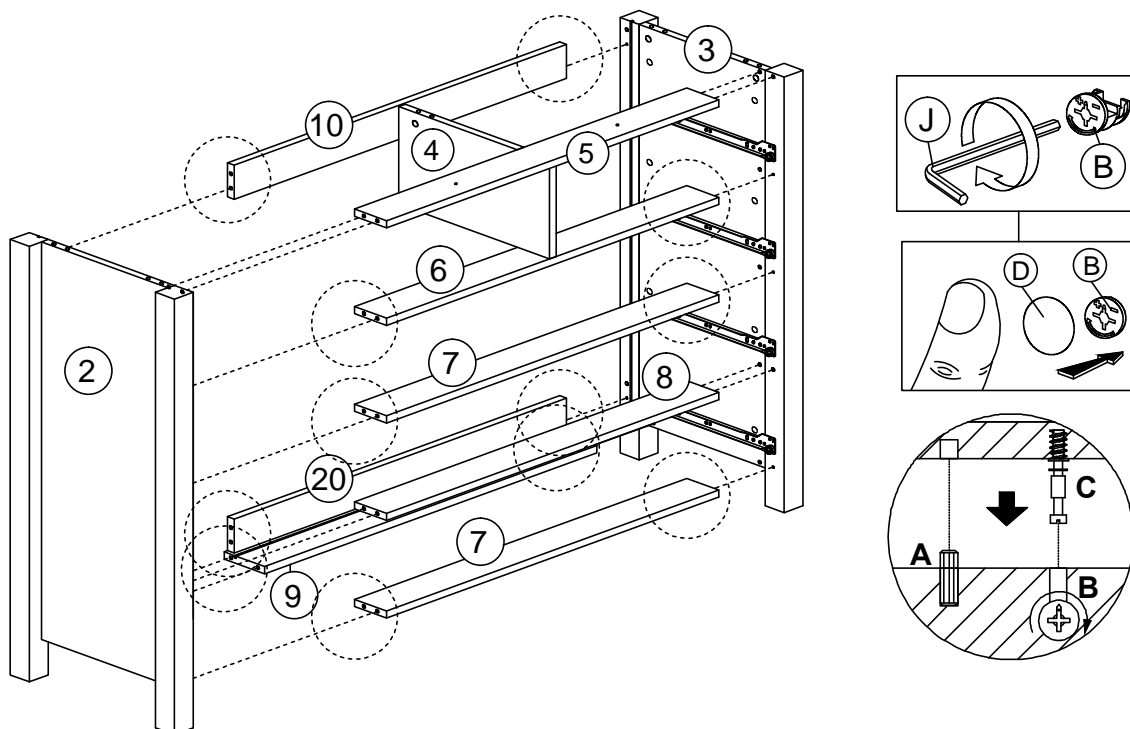

B		CAM NUT	12
D		CAM CAP	12
J		ALLEN KEY M4	1



THE USE OF POWER TOOLS TO ASSEMBLE THIS PRODUCT WILL INVALIDATE ANY CLAIM AND MAY DAMAGE THIS PRODUCT MAKING IT UNSAFE.



STEP 11

B		CAM NUT	6
D		CAM CAP	6
J		ALLEN KEY M4	1
O		PVH 3MM -871MM	1
F		CB SCREW M4 x 38MM	2

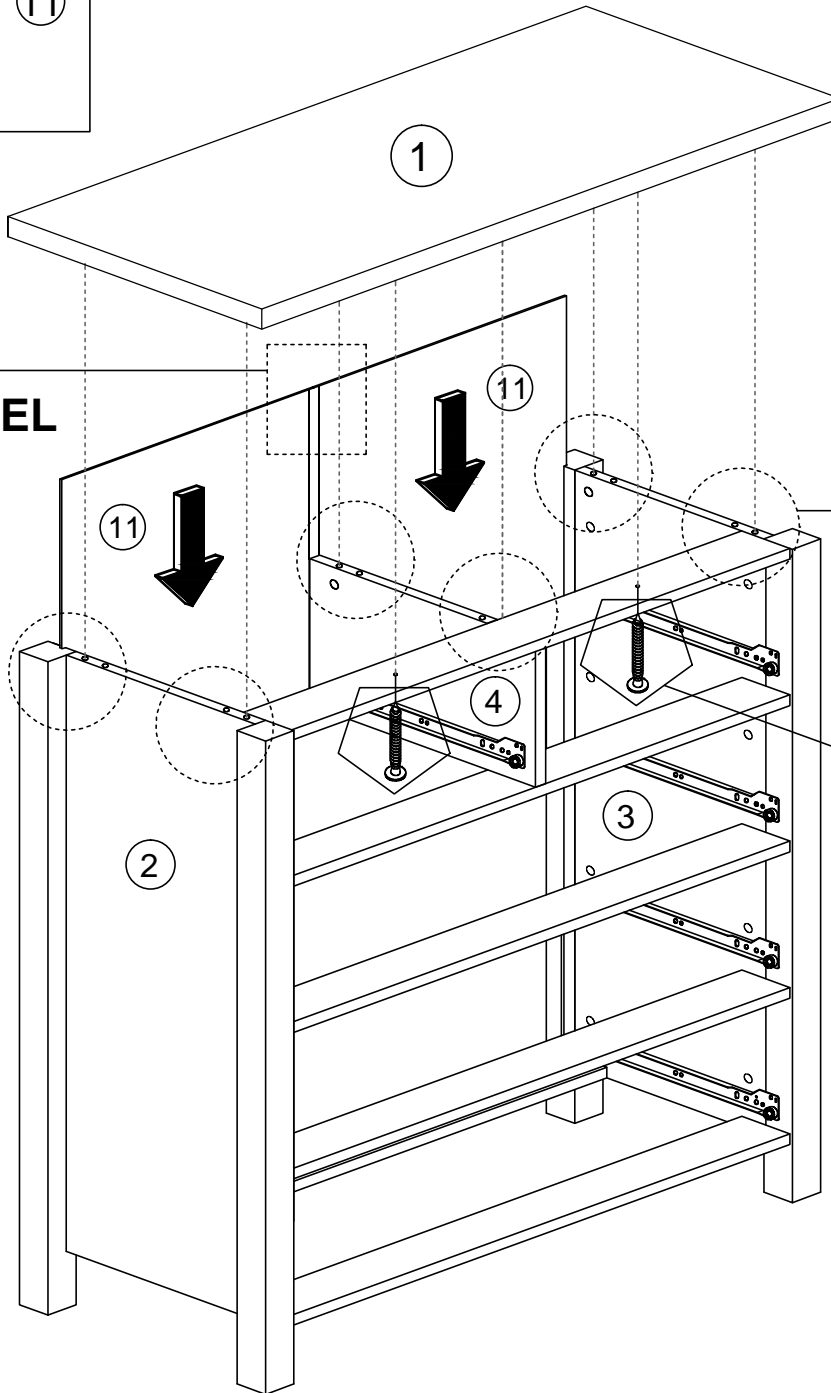
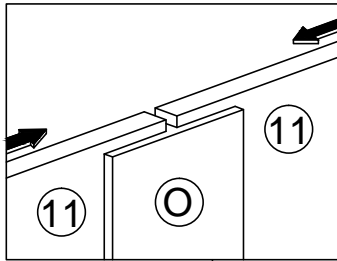

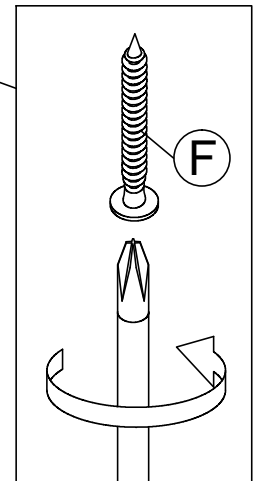
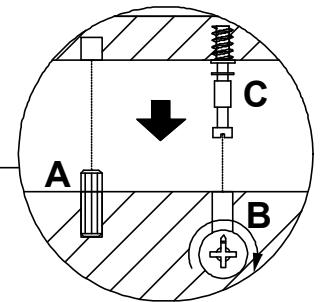
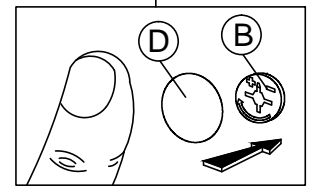
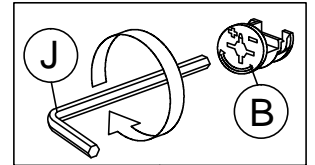

**SLOT IN
BACK PANEL**



THE USE OF POWER TOOLS TO ASSEMBLE THIS PRODUCT WILL INVALIDATE ANY CLAIM AND MAY DAMAGE THIS PRODUCT MAKING IT UNSAFE.



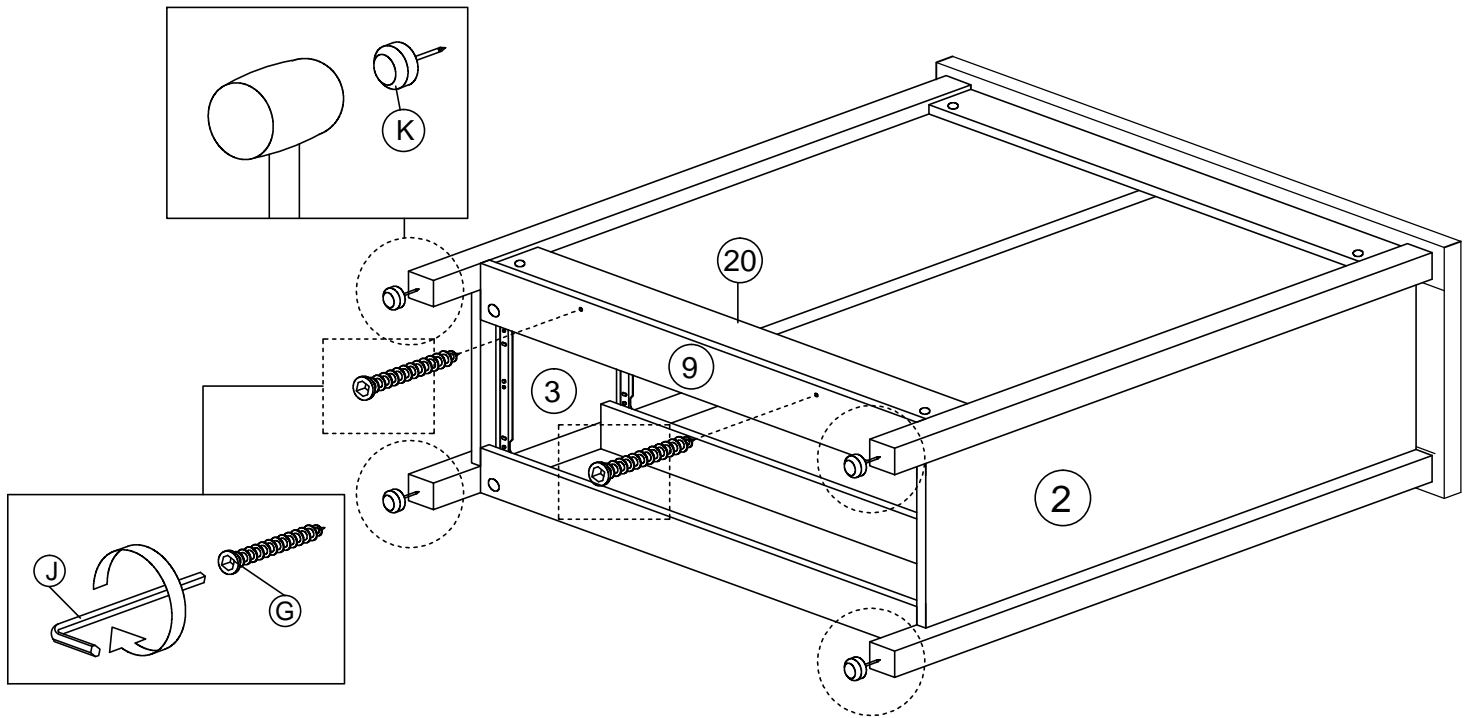

STEP 12

G		CSK CAP WOOD M6 x 40MM	2
J		ALLEN KEY M4	1
K		PVC NAIL WITH PIN 5/8	4



STEP 13

E		CB SCREW M3.5 x 16MM	8
L		PVC CORNER L BRACKET	4

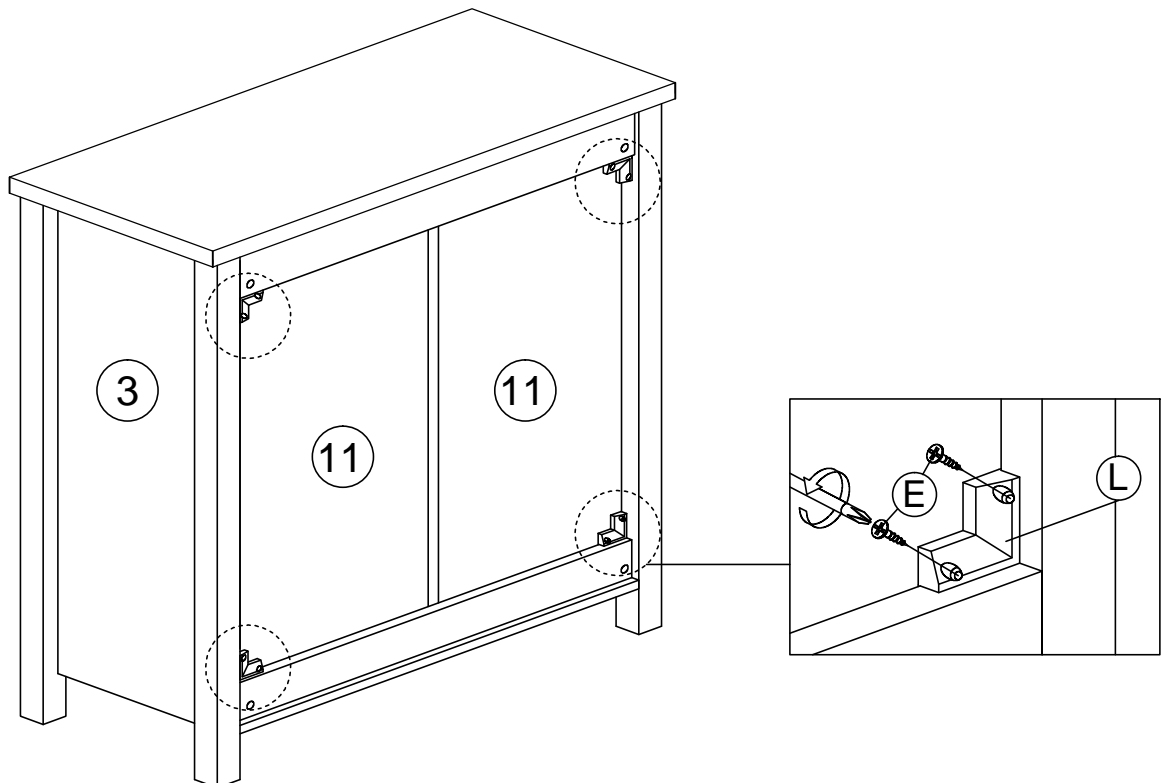

THE USE OF POWER TOOLS TO ASSEMBLE THIS PRODUCT WILL INVALIDATE ANY CLAIM AND MAY DAMAGE THIS PRODUCT MAKING IT UNSAFE.



STEP 14

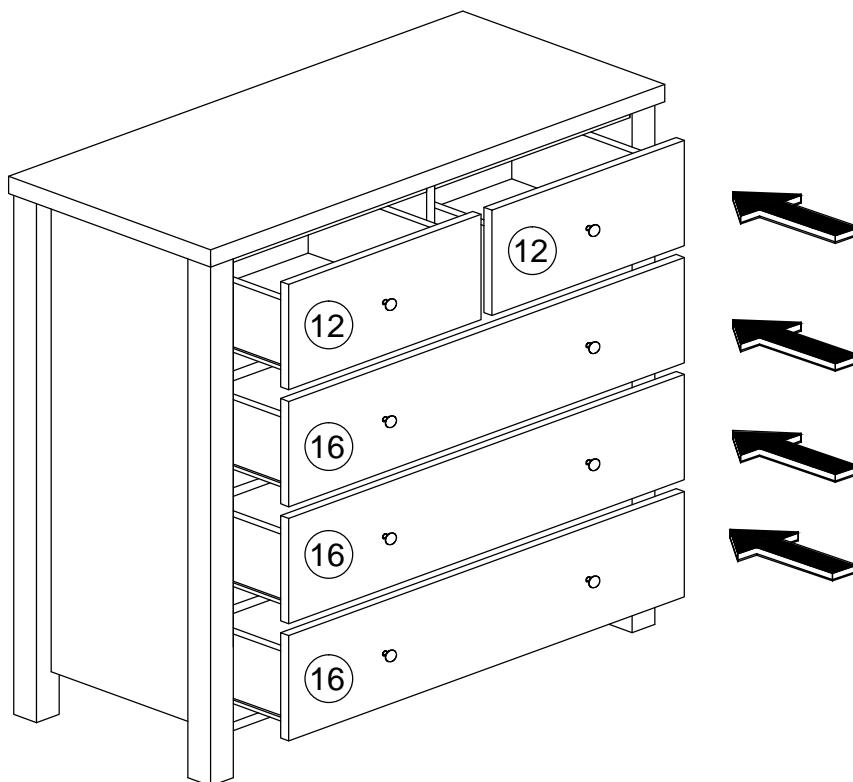

COMPLETED

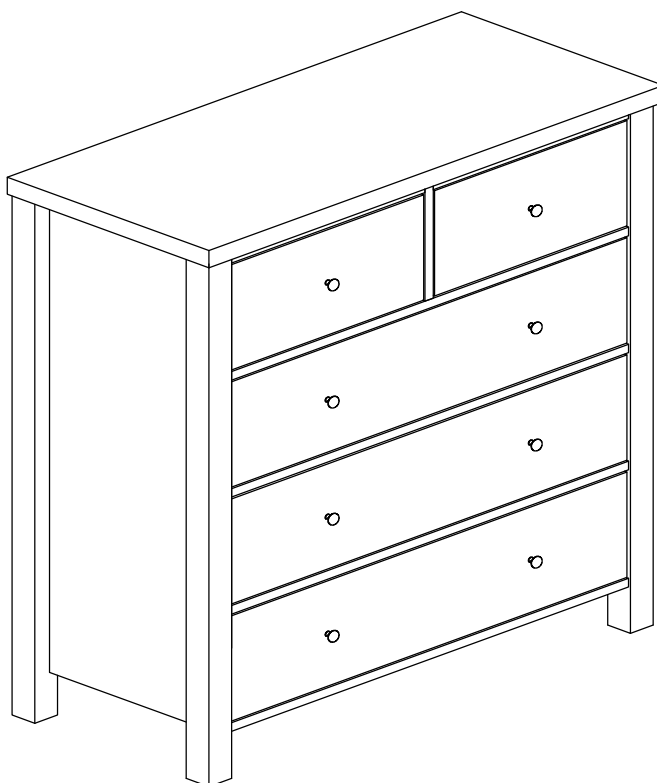

THE USE OF POWER TOOLS TO ASSEMBLE THIS PRODUCT WILL INVALIDATE ANY CLAIM AND MAY DAMAGE THIS PRODUCT MAKING IT UNSAFE.



Installation of Anti-Tip Restraint

Kit includes:

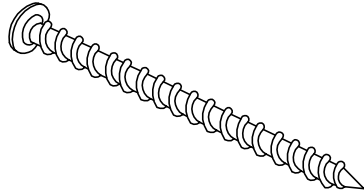

A (x1)
Long screw

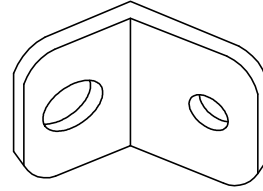

B (x2)
Mounting bracket

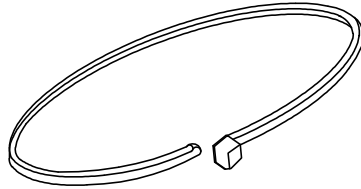

C (x1)
Restraint strap

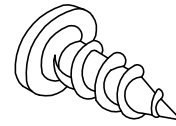

D (x1)
Short screw



WARNING



Serious or fatal crushing injuries can occur from furniture tip-over. To help Prevent tip-over:

- Install tip-over restraint provided
- Place heaviest items in the lower drawers
- Do not set TV's or other heavy objects on top of this product
- Never allow children to climb or hang on drawers, doors or shelves
- Never open more than one drawer at a time
- Do not defeat or remove the drawer interlock system

Use tip-over restraints may only reduce but not eliminate the risk of tip-over.

IMPORTANT: Use of this safety kit is mandatory. This restraint is not a substitute for proper adult supervision. Failure to detach this restraint before moving furniture may result in injury and damage.

FITTING OF ANTI-TIP SAFETY STRAP

STEP 1:

- Attach the mounting bracket (b) to the furniture in the solid part below the top panel a few inches away from the side of the unit.
- Screw (d) through the smallest hole of (b).

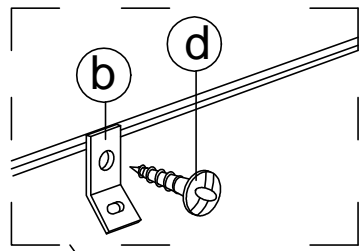

BACK SIDE OF TOP PANEL

STEP 2:

- Locate a stud in behind the have to
- Place the other mounting bracket (b) on the wall stud 2 inches below the mounting bracket secured to the back of your unit.
- Attach to the wall stud using (a) through the smaller hole of (b).

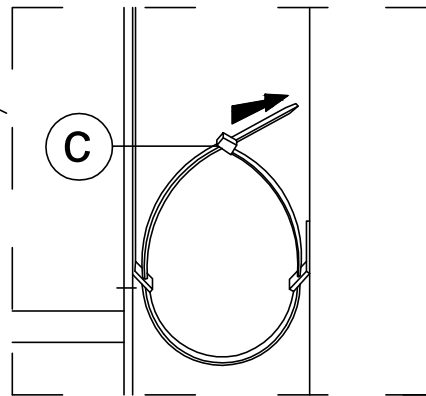
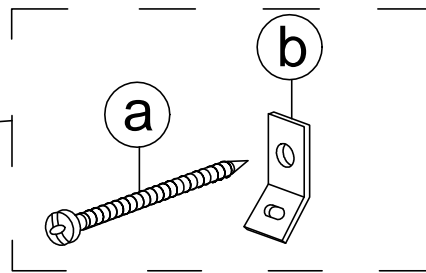

STEP 3:

- Repeat the same step a few inches away from the other side of the unit.
- Place the furniture into position so both mounting brackets are vertically in line.
- Lace the end of the restraint strap through the larger holes in each mounting bracket.
- Secure the straps and lock into place.

FURNITURE

WALL

