

CONGRATULATIONS ON THE PURCHASE OF YOUR NEW MAILBOX.
YOU HAVE MADE A GREAT DECISION!

This mailbox is invented and patented after many generations have had difficulties identifying their property addresses at night time. This new mailbox contains exterior illuminated numbers or letters that will help the general public, law enforcement and fire rescue department to quickly identify a home's property address. If there are any natural disasters or there is loss of power, this mailbox would still light up the property address and help rescue team find its locations.

This mailbox is made of heavy duty pvc plastic, and flexible solar panel (the new technology) on its roof that powers an internal battery used to illuminate the property address via L.E.D lights. The numbers are easily identified during the day due to the color and design. But at night is when the value of the mailbox comes alive.

The interior space of the mailbox remains open to receive all correspondences as a standard mailbox.

This mailbox was invented and patented by Efrain Fonseca

ITEMS CONTAINED IN YOUR BOX:

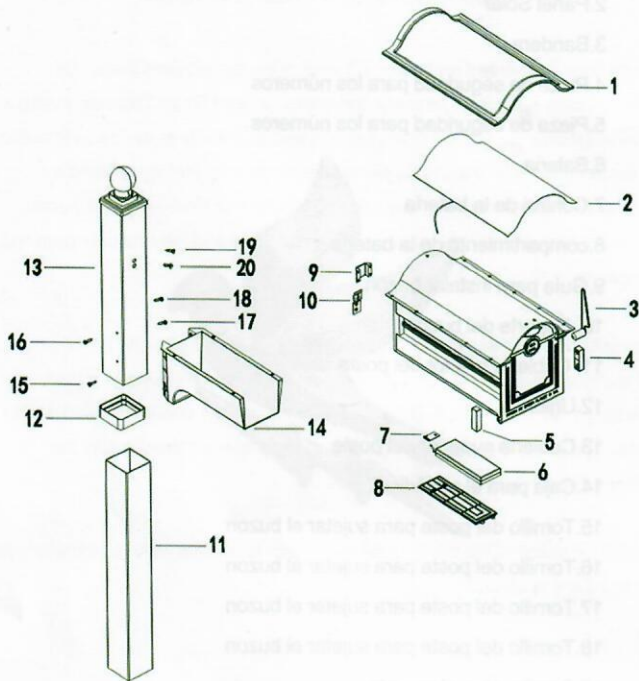

RECOMMENDATIONS: Clean your mailbox with soap and water.

- 1.Solar panel trim
2. Solar panel
3. Flag
- 4.Piece for lock Numbers Right side
- 5.Piece for lock numbers left side
- 6.Battery
- 7.Battery control
- 8.Battery box comparment
- 9.Guide to install mailbox
- 10.Mailbox bracket
- 11.Botton pole cover
- 12.Joint
- 13.Top pole cover
- 14.Newspaper box
- 16.Pole screw to secure the mailbox
- 17.Pole screw to secure the mailbox
- 18.Pole screw to secure the mailbox
- 19.Screw for bracket
20. Screw for bracket



WARNING:

VERIFY THERE ARE NO CABLES OR PIPES BURRIED UNDERGROUND THE MAILBOX LOCATION BEFORE DIGGING

THE MAILBOX NEEDS TO BE INSTALLED WITH THE MAXIMUM AMOUNT OF SUN EXPOSURE.THIS WILL ENSURE THE SOLAR PANEL RECEIVES SUFFICIENT SUN TO CHARGE THE INTERNAL BATTERY

TOOLS AND MATERIALS REQUIRED FOR INSTALLATION.

TOOLS NOT INCLUDED.

1. 4"x 4"x 82" PRESSURE TREATED WOOD
2. BUBBLE LEVEL (VERIFY POST IS VERTICALLY PLUMBED)
3. MINIMUM ONE BAG OF CONCRETE MIX
4. A SHOVEL OR ANY TOOL TO MAKE A HOLE
5. PHILLIPS SCREW DRIVER OR ANY CORDLESS DRILL – Bit Size #2
6. 5/16" HEX HEAD WRENCH

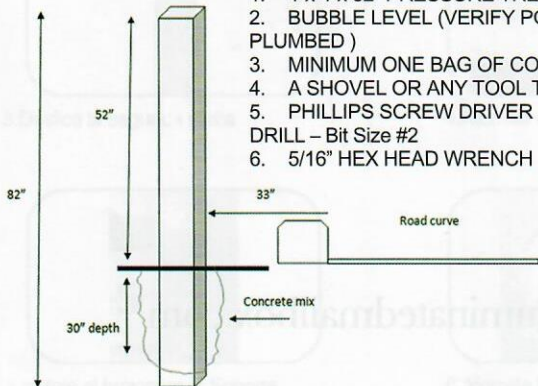

THE ASSEMBLY OF THE MAILBOX IS SIMPLE AND VERY EASY.

ALL HOLES ARE PREDRILLED

Follow the steps to install the mailbox in numerical order

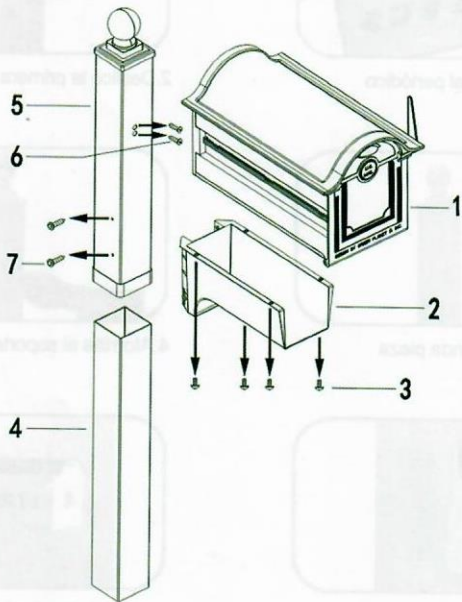

TAKE THE FOLLOWING STEPS



1. INSTALL THE NEWS PAPER BOX



2. INSERT FIRST SLEEVE INTO
4" X 4" POST



3. INSERT THE SECOND SLEEVE ON
TOP



4. SCREW THE GUIDE SUPPORT
BRACKET



5. INSTALL THE MAILBOX INTO THE
GUIDE SUPPORT



6. SECURE THE MAILBOX TO
POST WITH TWO SCREWS AT
EACH SIDE