

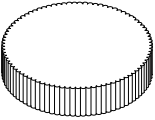
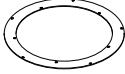
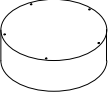

ASSEMBLY INSTRUCTION

ITEM NO: FSH2560 ROUND COFFEE TABLE

Thank you for purchasing this quality product. Be sure to check all packing material carefully for small parts which may have come loose inside the carton during shipment. Separate, identify and count all parts and metal hardware. Compare with parts list to be sure all parts are present. If any part(s) are missing or damaged, please contact your local furniture dealer. For efficient and speedy service, please indicate the model number and code letter of part(s) needed.

*** Do not fully tighten bolts until fully assembled ***

No.	COMPONENT LIST	Q'ty	No.	COMPONENT LIST	Q'ty
A	 TABLE TOP	1pc	B	 ROUND IRON BRACKET	1pc
B	 LEG	1pc			
No.	HARDWARE LIST	Q'ty	No.	HARDWARE LIST	Q'ty
1	 Bolts 1/4x0.6"	10pcs	2	 Allen key K4	1pc

Step 1: Use Allen key (2) remove bolt (1) outer unclockwise. Pull locking strap to leg (B) out Table Top (A)

Step 2: Rotate Leg (B) let it match the table drill hole. Then fully tighten all bolt.

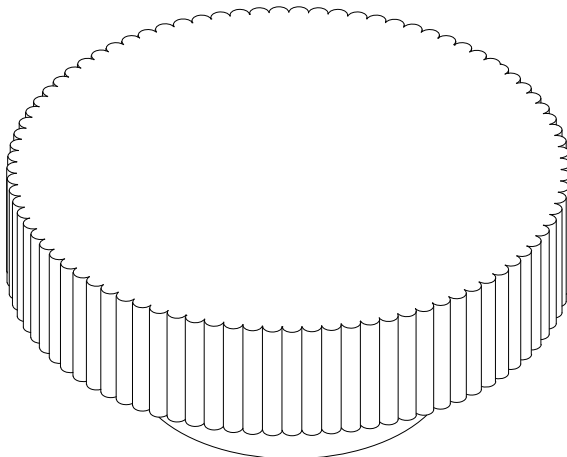
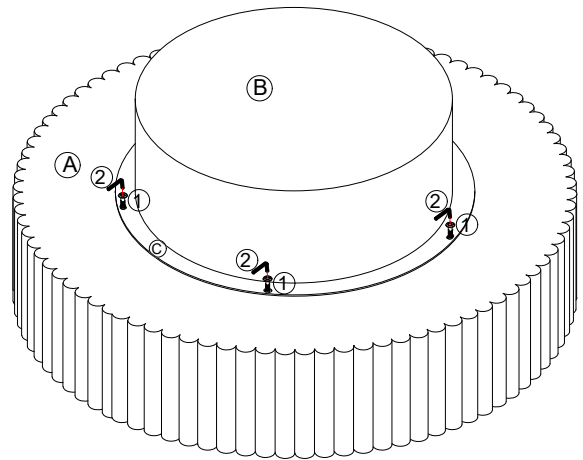
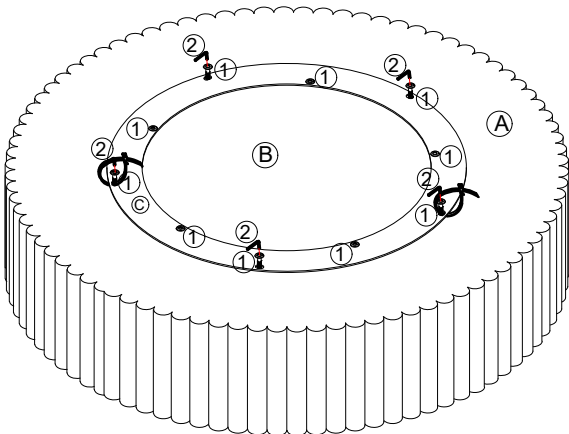

**FINISH .
THANK YOU !**

MADE IN VIETNAM