

ASSEMBLY INSTRUCTION

7016 Accent Chair

Parts List

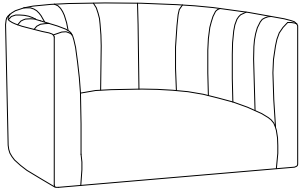

(A) Chair x 1

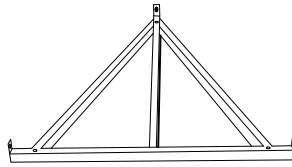

(B) Metal Base x 1

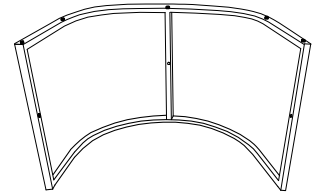

(C) Metal frame x 1

Hardware List



① Short Bolts x 3



② Long Bolts x 3



③ Flat Washers x 6



④ Spring Washers x 6



⑤ Allen Key x 1

Step 1

Remove all the parts from the carton, and place them on a protected surface or carpet. Attach Metal Base (B) to the Metal Frame (C) as below drawing instruction, Fix them with Short Bolts (1), Spring Washers (4) and Flat Washers (3) by Allen Key (5), Please insert all the 3 short bolts to holes first, then full tighten them later. And now the metal base of the chair is finished assembling.

Reminder: 1. DO NOT reverse the direction of triangle metal base.

2. DO NOT fully tighten the bolts until all 3 bolts are adjusted and inserted to their hole position.

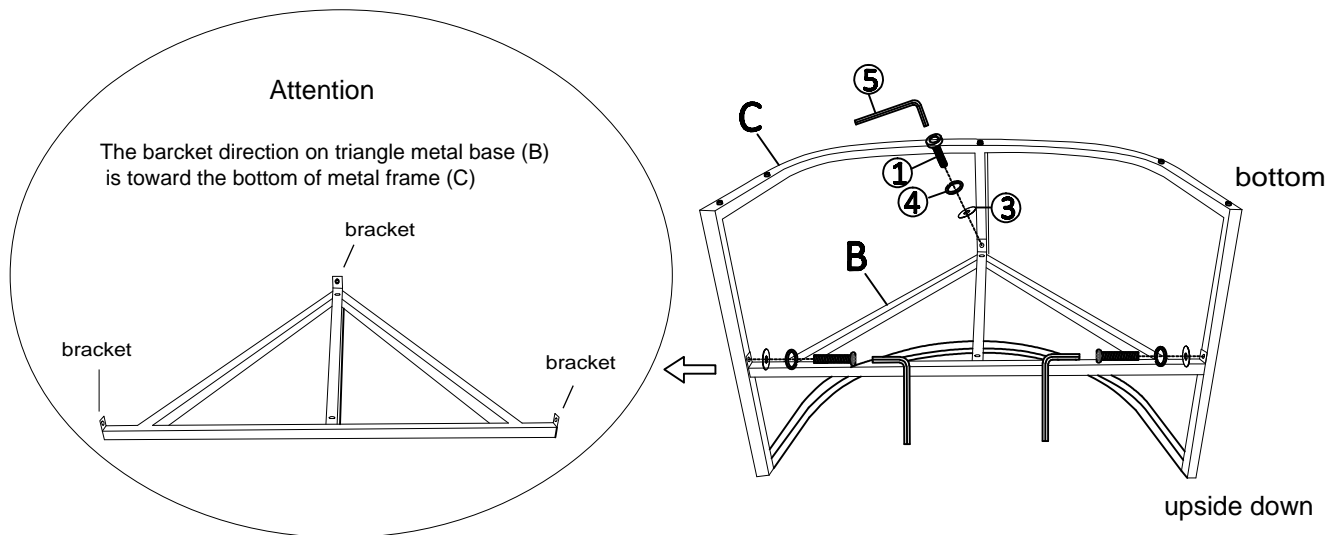

Step 2

Put the assembled Metal Base on the bottom of the Chair (A) as below instructed, align to their holes position of the metal base and the bottom of chair, then insert the 3pcs of Long bolts (2) with Spring washers (4), Flat Washers (3) to their hole position, fully tighten them with Allen Key (5) finally.

Reminder: 1. Insert all the 3 bolts first.

2. Fully tighten the bolts later.

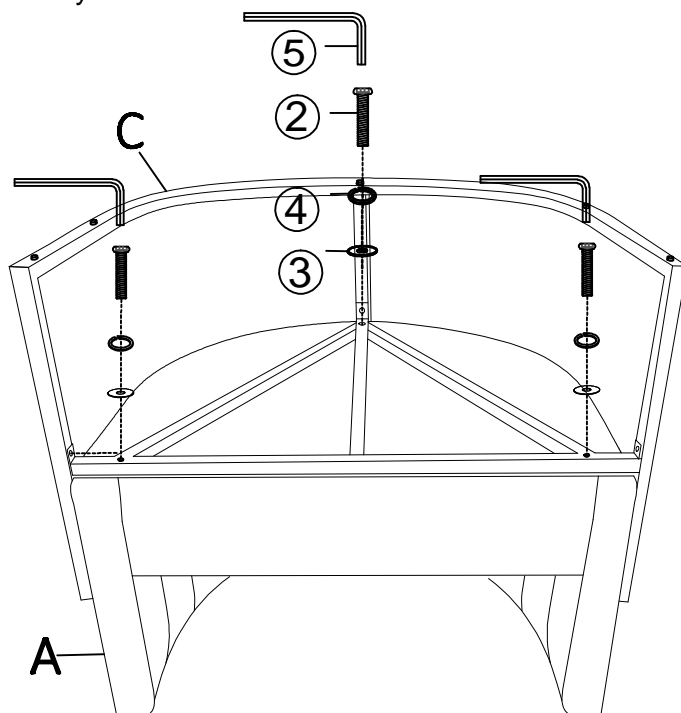

Step 3

Now turn the accent chair upright on the floor, and the assembly is completed.

- * Reminder: You can adjust the bottom five adjustment feet to keep the chair in the same level.

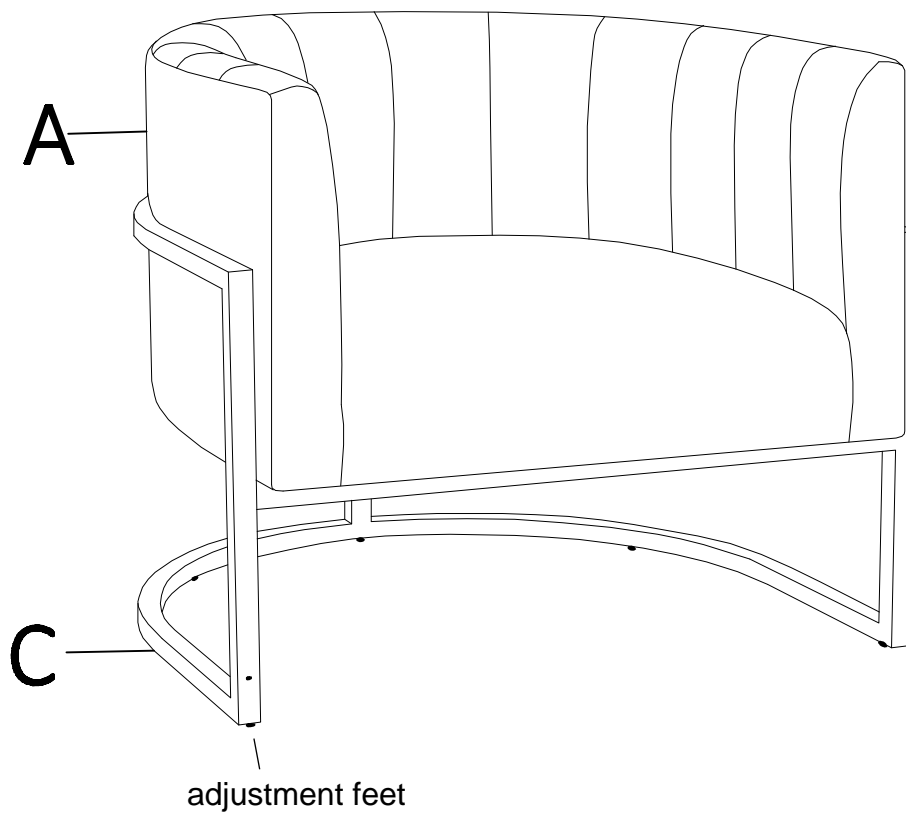

* Cleaning & Care

Treat surface with care. Surface is not scratch resistant. Clean surface with a dry or damp soft cloth. Do not use abrasive cleaners. Or you can use dry solvee cleaner, spray dry cleaner to the dirt stain fabric, then wipe the dirty with wet cloth.

- * Please contact with customer service , if you need any support .