

# Assembly Instructions

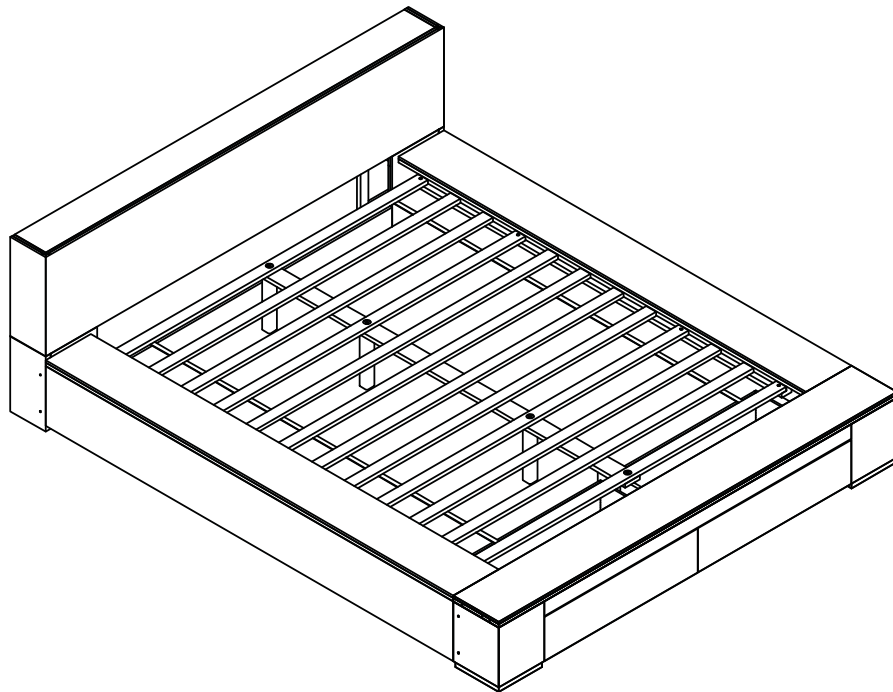

## ASSEMBLY RATING

The Assembly Rating is a 5-point system that shows the degree of effort needed in assembling a specific product (with 1 being easy and 5 being difficult). For some products, two persons are recommended.

EASY  DIFFICULT

## Tools Required For Assembly:

Allen Wrench

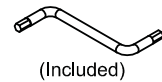

Wrench



Phillips Screwdriver



2 PERSONS RECOMMENDED

# ASSEMBLY & CARE ADVICE

FOR YOUR FURNITURE TO LAST, CORRECT ASSEMBLY AND PROPER MAINTENANCE ARE NECESSARY. PLEASE FOLLOW THE INFORMATION PROVIDED BELOW TO FULLY ENJOY YOUR FURNITURE.

## BASIC ASSEMBLY TECHNIQUES

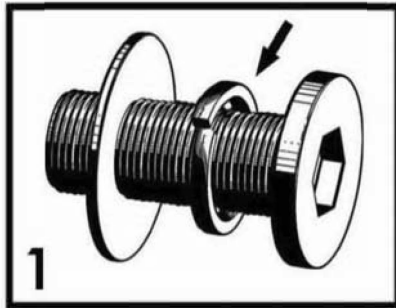

When lock or spring washer is used in an assembly, please make sure the lock or spring washer is placed between the larger flat washer and the head of the screw or bolt.

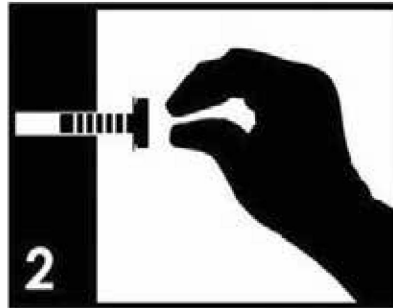

Position each part correctly and insert screws or bolts into their respective holes by hand tighten or using the proper hand tool. Only tighten when step is completed or when instructed to do so.

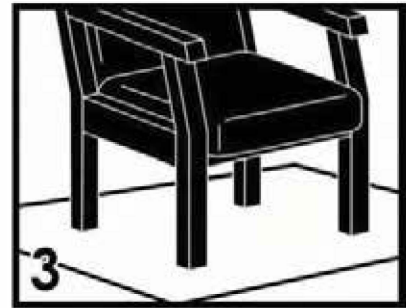

Use cardboard or carpet area when assembling furniture to prevent scratches. Make sure the furniture rests on a flat and level surface with each leg evenly touching the floor.

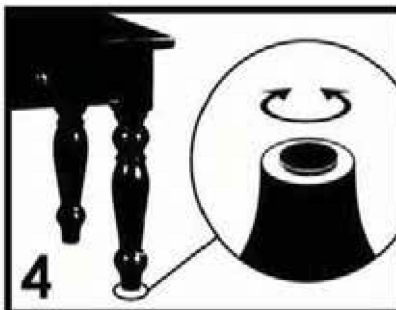

Some furniture comes with height adjustment knobs underneath each leg. To lower or to raise each leg, you need to turn clockwise or counterclockwise, respectively.

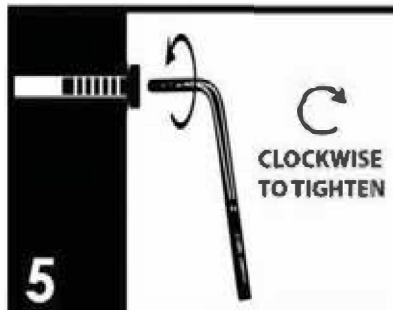

Make sure all parts are properly aligned, then use the appropriate hand tool to completely tighten the bolts or screws. Do not use power tools and do not overtighten.

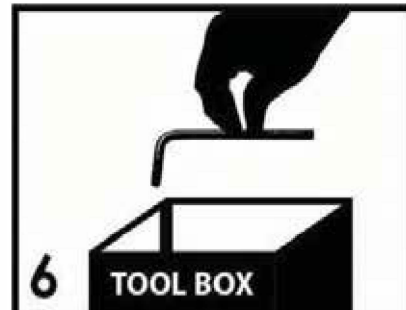

Save the instructions and store the Allen wrench or any supplied tool for later maintenance. After two weeks, check and tighten any loose hardware and repeat again every six months thereafter.

IT IS THE USER'S RESPONSIBILITY TO MAINTAIN THE FURNITURE. THE HARDWARE MAY LOOSEN OVER TIME AND MAY CAUSE THE FURNITURE TO BE WOBBLY AND UNABLE TO SUPPORT ITS INTENDED WEIGHT CAPACITY. THIS MAY LEAD TO COLLAPSE AND MAY CAUSE SERIOUS INJURY.





**FAILURE TO FOLLOW THE GUIDELINES ABOVE MAY RESULT IN INJURY AND/OR PROPERTY DAMAGE.**







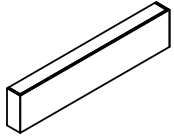
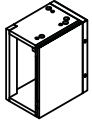
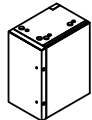
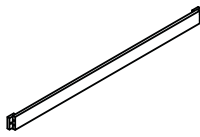
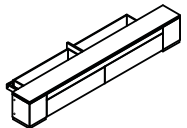
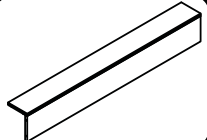
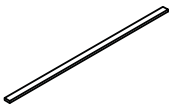
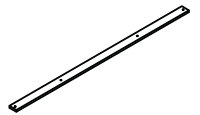



Before you begin, please read Page 2 of "Assembly and Care Advice".

And remember, do not tighten until each step is completed or instructed.

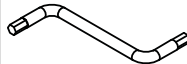
### Parts List

-  #1 x 1 pc  
Headboard
-  #2R x 1 pc  
Right H/Board Leg
-  #2L x 1 pc  
Left H/Board Leg
-  #3 x 1 pc  
Leg Support
-  #4 x 1 pc  
FB w/2 Drawer
-  #5 x 2 pcs  
Side Rail
-  #6 x 12 pcs  
Slat
-  #7 x 1 pc  
Slat Center
-  #8 x 3 pcs  
Slat Support Leg

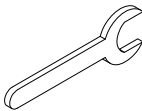
### Hardware List

-  #A x 8 pcs  
Bolt 1/4" x 1-3/16"
-  #B x 8 pcs  
Lock Washer
-  #C x 8 pcs  
Flat Washer
-  #D x 1 pc  
Allen Wrench
-  #E x 4 pcs  
Dowel
-  #F x 8 pcs  
Threaded Stud
-  #G x 8 pcs  
Hex Nut
-  #H x 8 pcs  
Beveled Washer
-  #I x 1 pc  
Wrench
-  #J x 8 pcs  
Screw 1"



Due to the size and/or weight of this product, it is highly recommended that the assembly should be done near the area of its intended location. Make sure you have enough space to move around during the assembly. ALWAYS have at least two people to help with transporting and assembling the product to avoid any potential injury and/or damage.



1. Insert 2 dowels (#F) into each end of the leg support (#3), and the other ends of the dowels into the right and left H/board legs (#2).

2. Prepare 2 bolt assemblies by applying a lock washer (#B) onto the bolt (#A) then a flat washer (#C) onto that same bolt (#A). Insert a bolt assembly into each end of the leg support (#3) and secure using the Allen wrench (#D).

#A x 2 pcs  
#B x 2 pcs  
#C x 2 pcs  
#E x 4 pcs

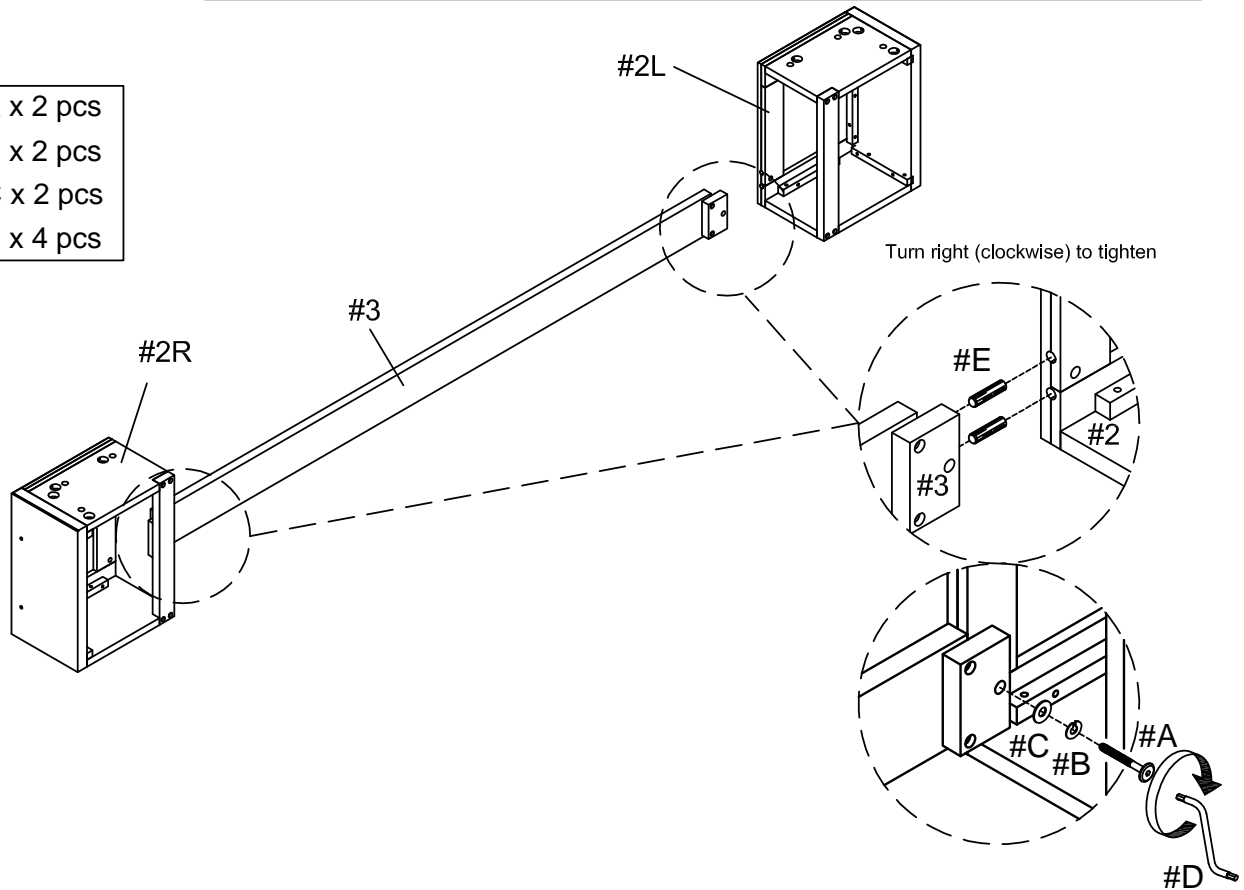

Note: Right and left are determined by facing the front of the footboard.



1. Prepare 6 bolt assemblies by applying a lock washer (#C) onto the bolt (#A) then a flat washer (#D) onto that same bolt (#A).

2. Carefully place the headboard (#1) onto the top of the H/board legs (#2). Insert 4 bolt assemblies into each end of the legs (#2) and secure using the Allen wrench (#D).

#A x 6 pcs  
#B x 6 pcs  
#C x 6 pcs

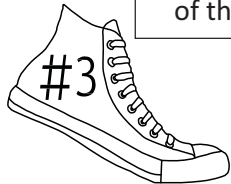
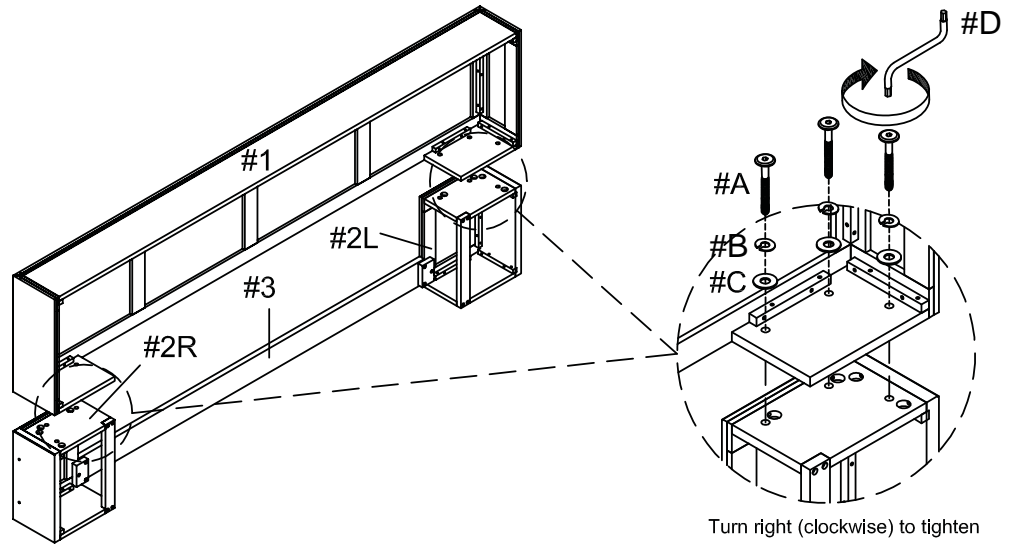

1. Insert 2 threaded studs (#F) into the holes along the sides of the headboard (#1) and footboard (#4). Turn right to tighten.

2. Apply each end of the side rails (#5) onto those threaded studs (#F).

#G x 8 pcs  
#H x 8 pcs  
#I x 8 pcs

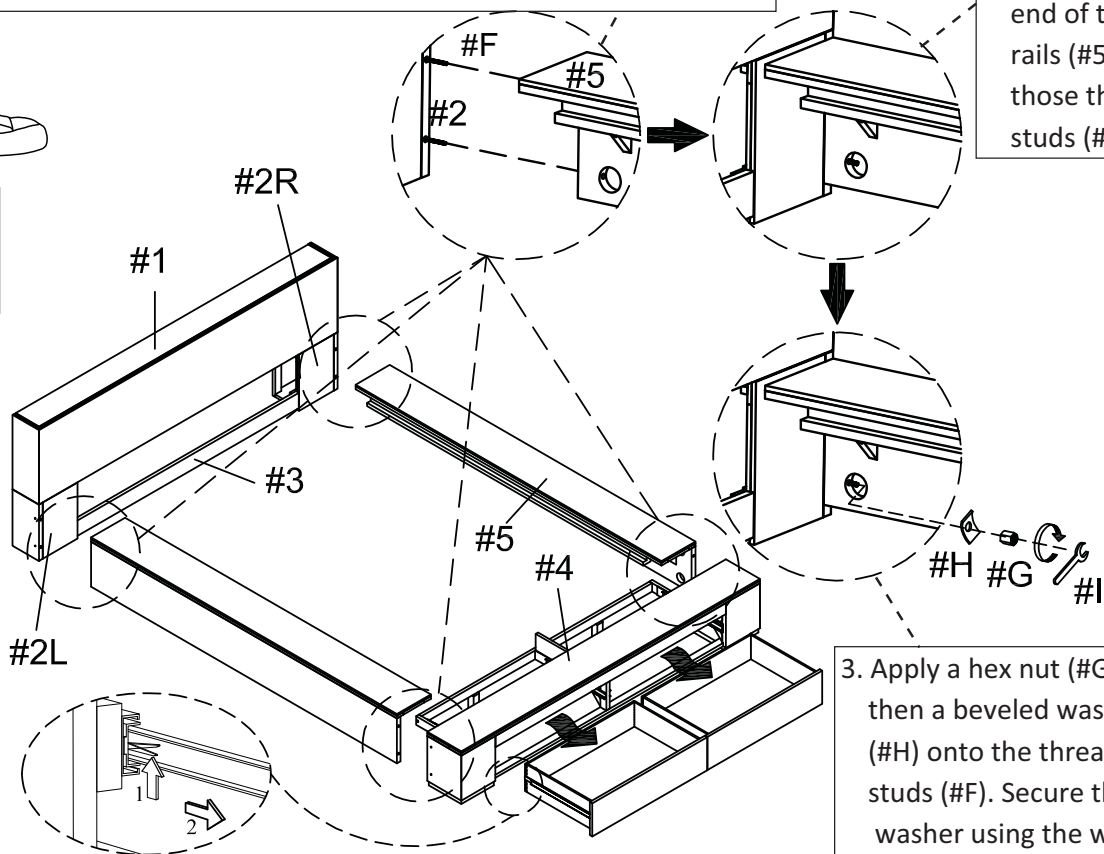

3. Apply a hex nut (#G) then a beveled washer (#H) onto the threaded studs (#F). Secure the washer using the wrench.



Insert the threaded ends of the slat supports (#8) into the holes along the slat center (#7). Turn right to tighten.

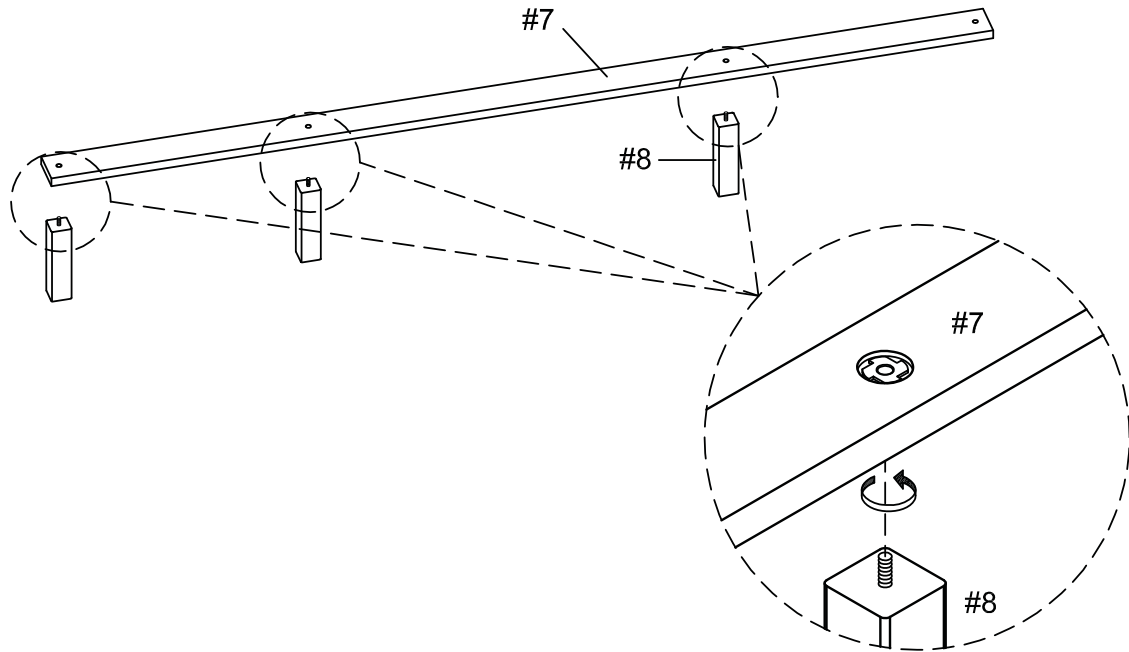

1. Apply the slats (#6) onto the side rails (#5).

2. Turn the slat support legs (#8) along the center to the right. This will connect the slat center (#7) to the slats (#6).

3. Insert a screw (#J) into the ends of the slats (#6). Secure using the Phillips screwdriver.

#J x 8 pcs

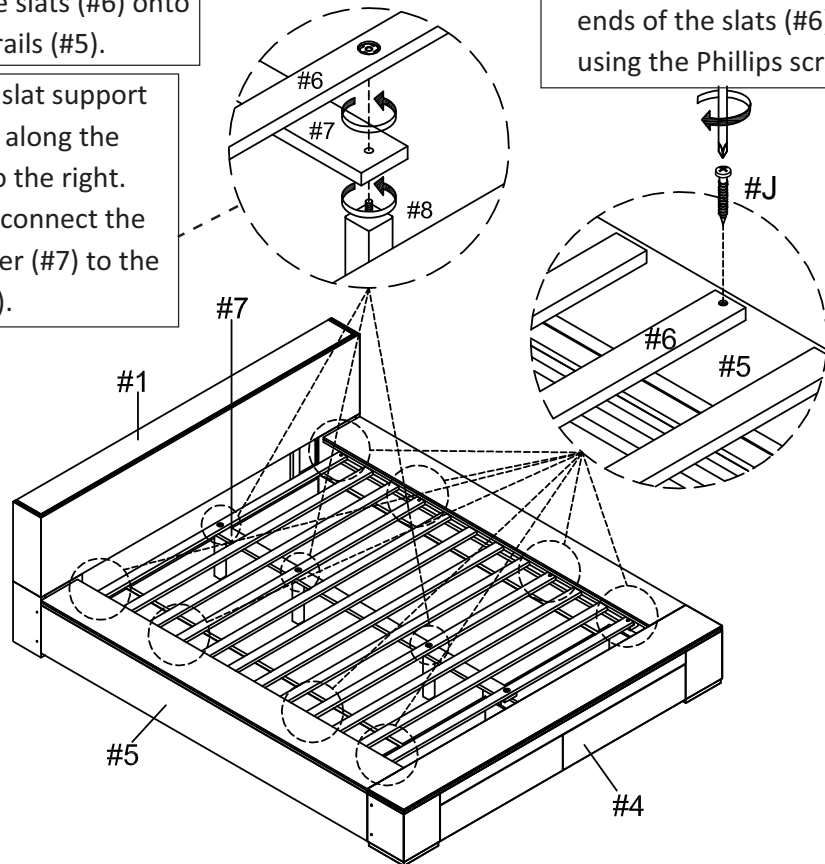

ASSEMBLY IS COMPLETED