

Assembly Instructions

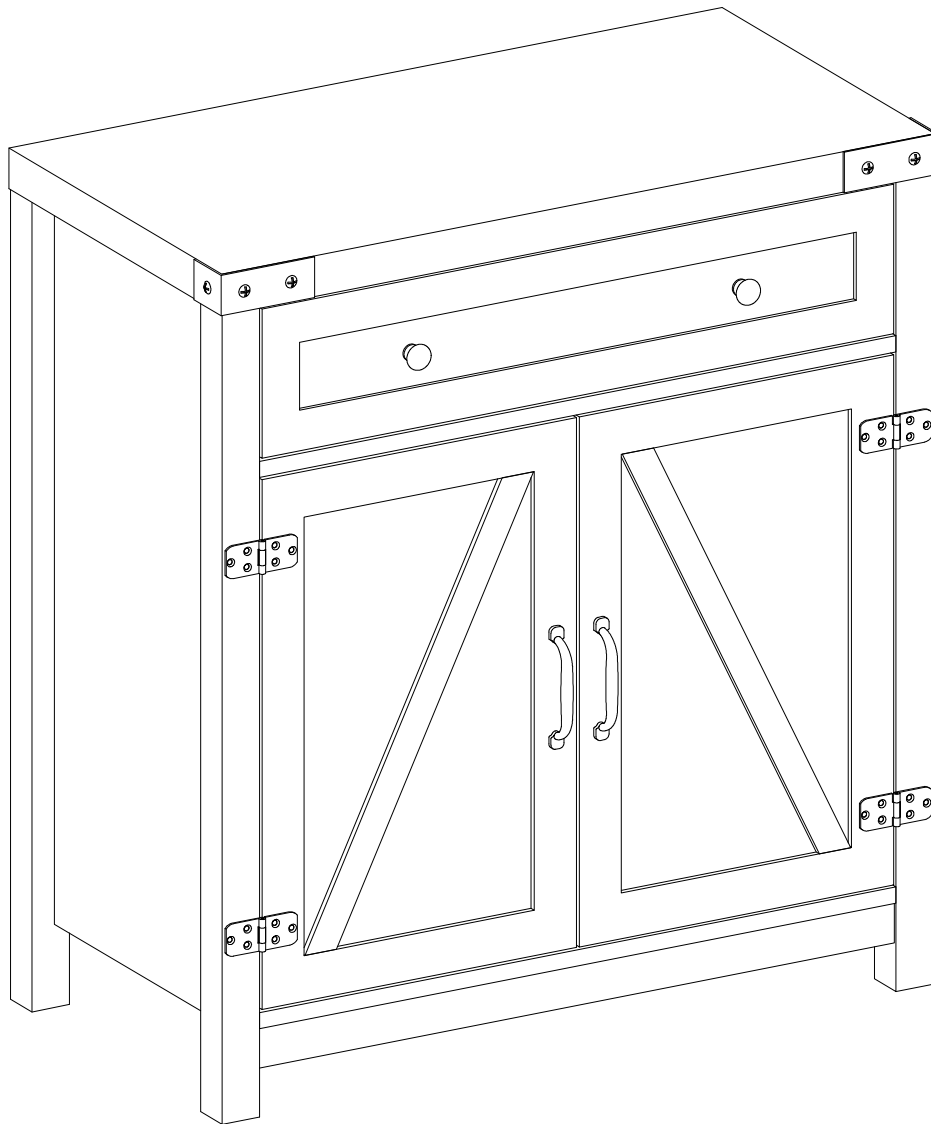

General Assembly Guidelines

- I. Ensure that all parts and hardware are available before beginning assembly.
- II. Follow each step carefully to ensure the proper assembly of this product.
- III. Two people are recommended for ease in the assembly of this product.
- IV. The three main types of hardware used to assemble this product are : wood dowels , screws and bolts.
- V. The provided glue is to secure wood dowels in place . When first inserting dowels , locate the appropriate hole for the dowel , place a small amount of glue in the hole and insert the dowel . Wipe away excess glue immediately.

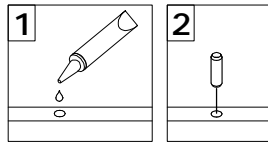

In future assembly steps when dowels are necessary to attach assembly parts together , place a small amount of glue on the end of the dowel before attaching parts together . Wipe away excess glue immediately.

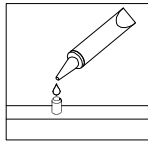

- VI. A Phillips head screwdriver is required for the assembly of this product .

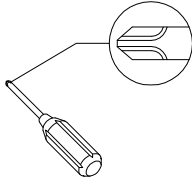



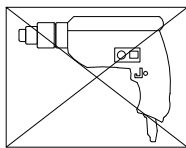



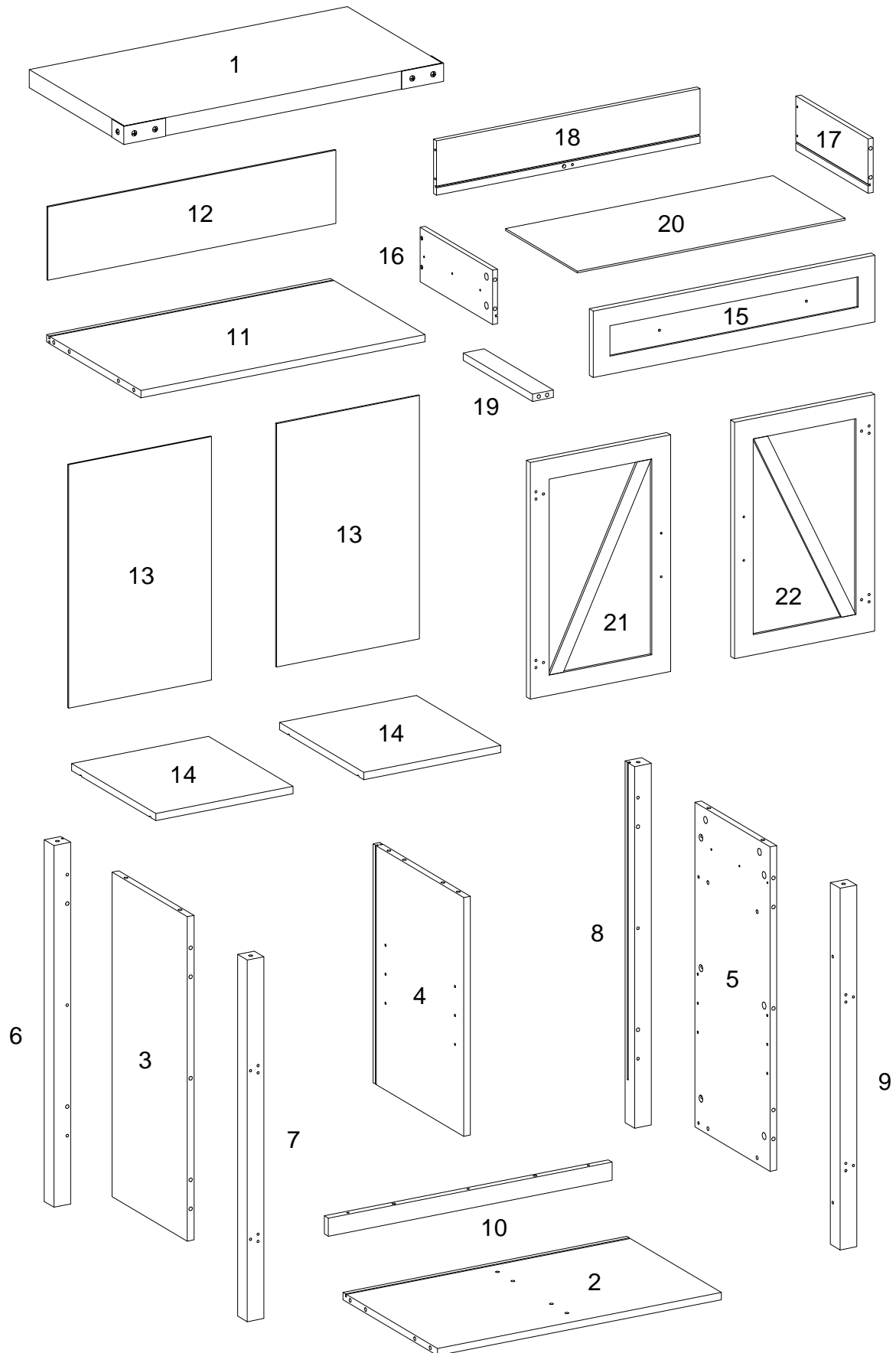







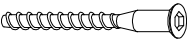

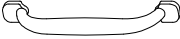

- VI. Power tools should not be used to assemble this product .



Parts List

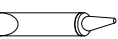

Hardware List



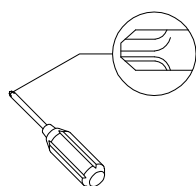





A		Ø8x30mm	Wooden dowel	28 pcs
B		Ø6x35mm	Cam bolt	31 pcs
C		Ø15x11mm	Cam lock	27 pcs
D		Ø15x 9 mm	Cam lock	4 pcs
E		Ø30mm	Sticker	31 pcs
F		Ø6x50mm	Screw	2 pcs
G		M 4	Hex Key	1 pc
H		Ø8x5x16mm	Shelf support pin	8 pcs
J			Handle	2 pcs
K		Ø4x9mm	Handle Bolt	2 pcs
L			Handle	2 pcs
M		Ø4x22mm	Handle Bolt	4 pcs
N			Bolt	2 pcs
P			Door stopper	2 pcs
Q		Ø3x12mm	Screw	24 pcs
R			Hinge	4 pcs
S			Plastic wedge	12 pcs
T		Ø3x17mm	Screw	12 pcs
U			Glue tube	1 pc
V		Ø4x32mm	Screw	5 pcs

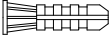

Philips head screwdriver required for assembly
(not included)

*The hardware quantities listed above are required for proper assembly.
Some extra hardware may also have been included.*

Hardware List

W		Ø3x12mm	Screw	12 pcs
X		Ø4x45mm	Screw	3 pcs
Y			Screw	1 pc
Z			Screw	1 pc
aa			Anchor	1 pc
bb			Velcro strap	1 pc
cc		Ø3x14mm	Screw	4 pcs
dd		12"	Drawer slider	1 set

* Note: This piece comes preassembled for shipping purposes and must be disassembled to complete the desk assembly.

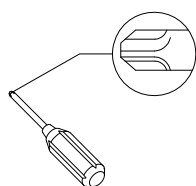

Philips head screwdriver required for assembly
(not included)

*The hardware quantities listed above are required for proper assembly.
Some extra hardware may also have been included.*

Step 1

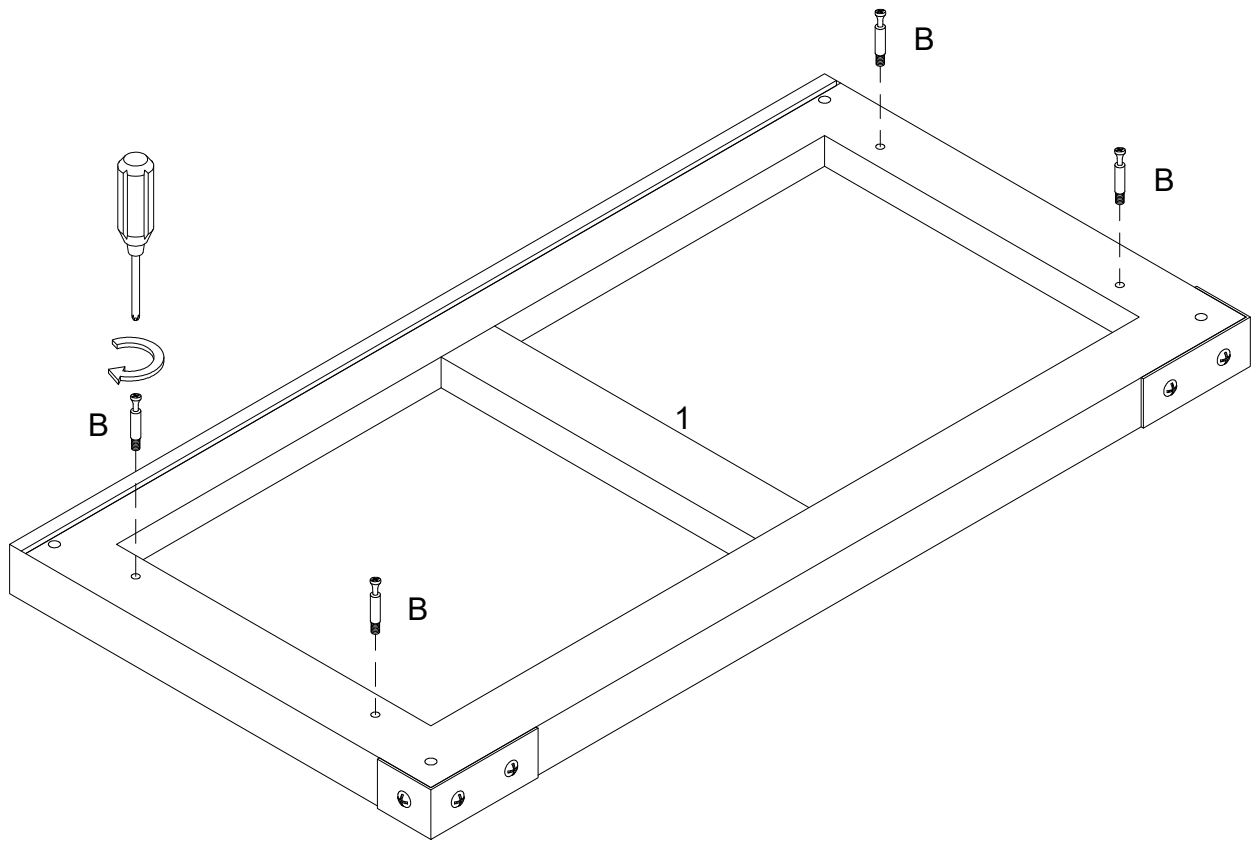

Using cam bolt (B) secure part (1) with Philips head screwdriver as per diagram.

Step 2

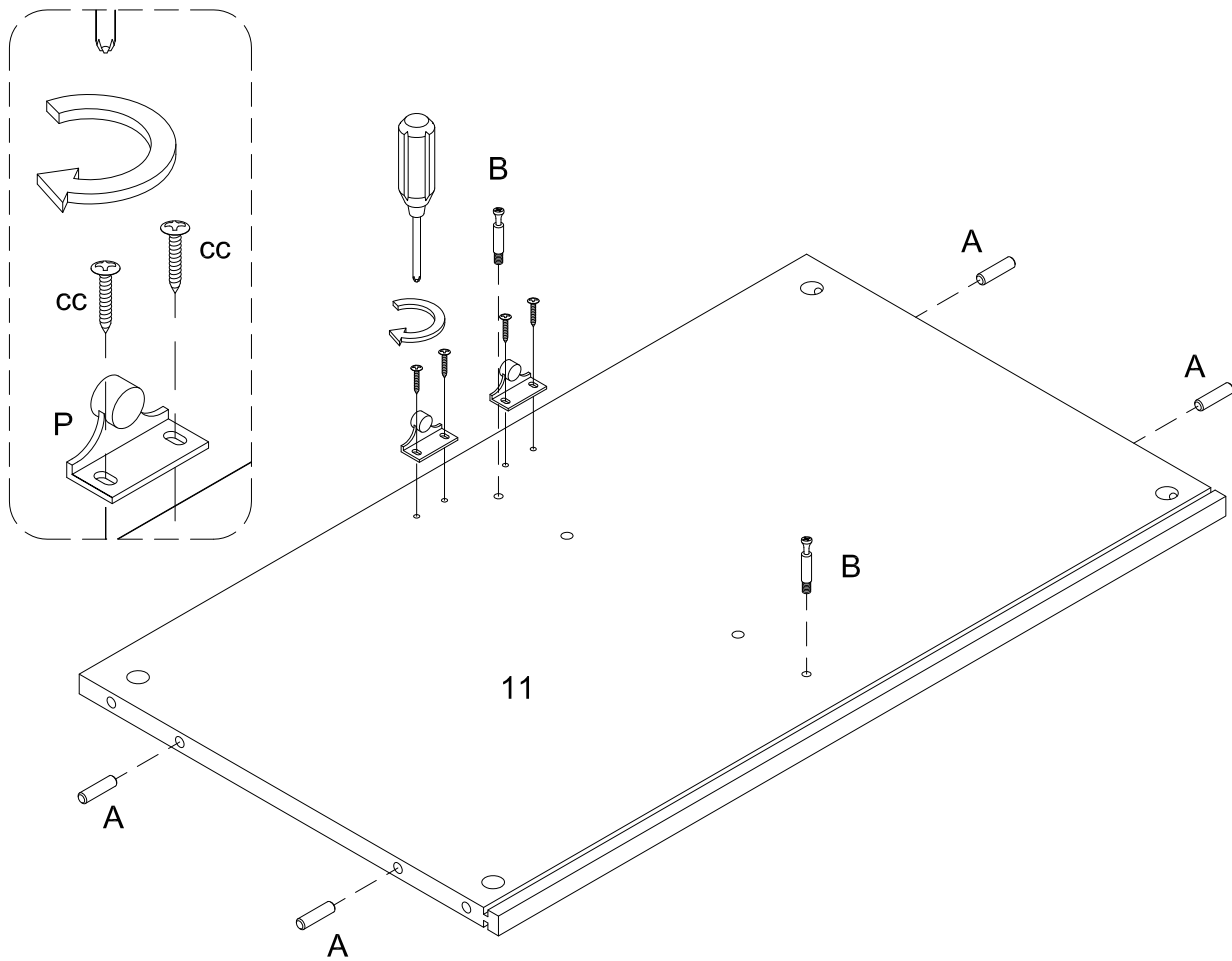

Insert wooden dowel (A) into part (11) ,using cam bolt (B) secure part (11) ,then using screw (cc) secure door stopper (P) into part (11) with Philips head screwdriver as per diagram.

Step 3

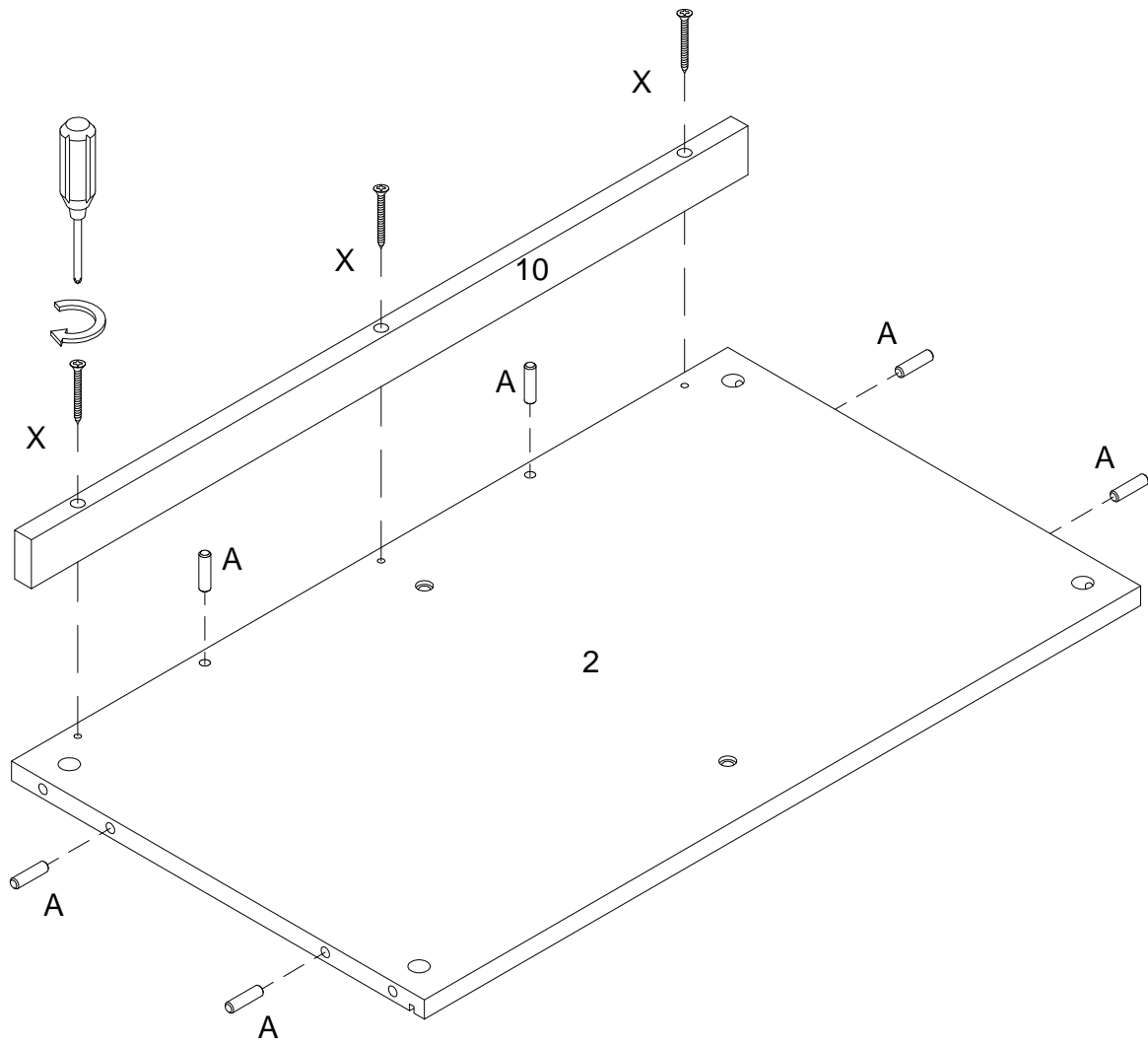

Insert wooden dowel (A) into part (2) ,then using screw (X) secure part (10) into part (2) with Philips head screwdriver as per diagram.

Step 4

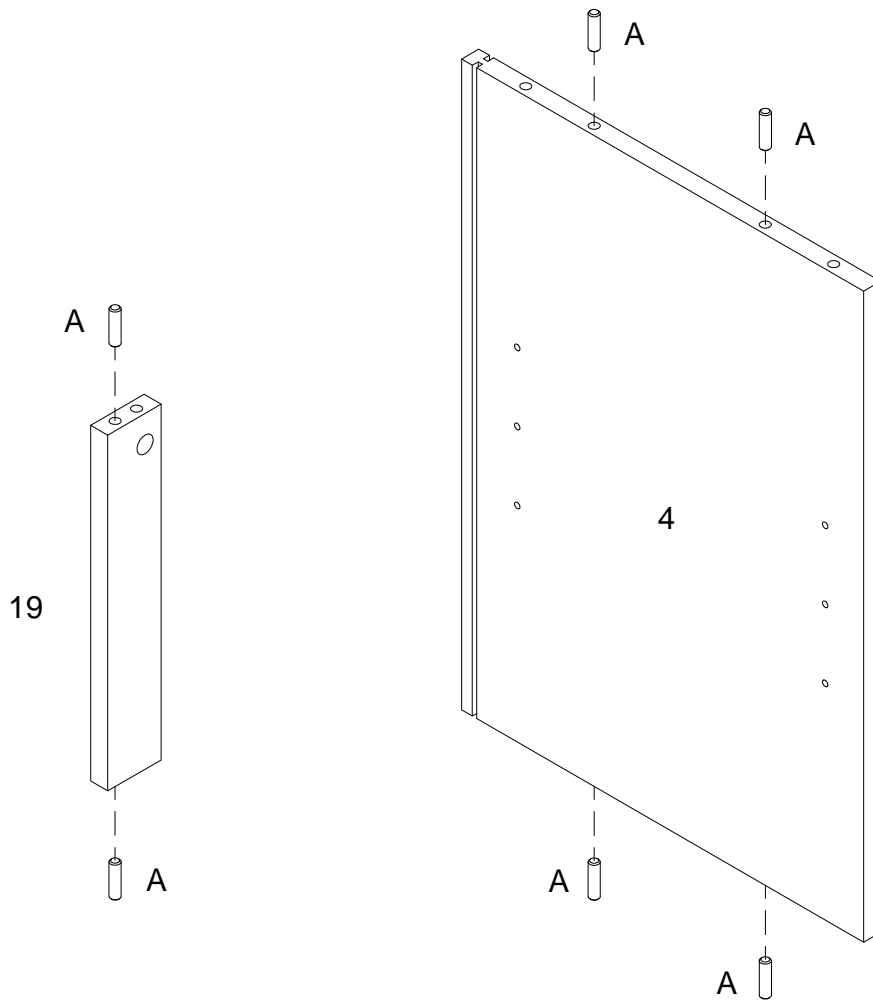

Insert wooden dowel (A) into parts (4,19) as per diagram.

Step 5

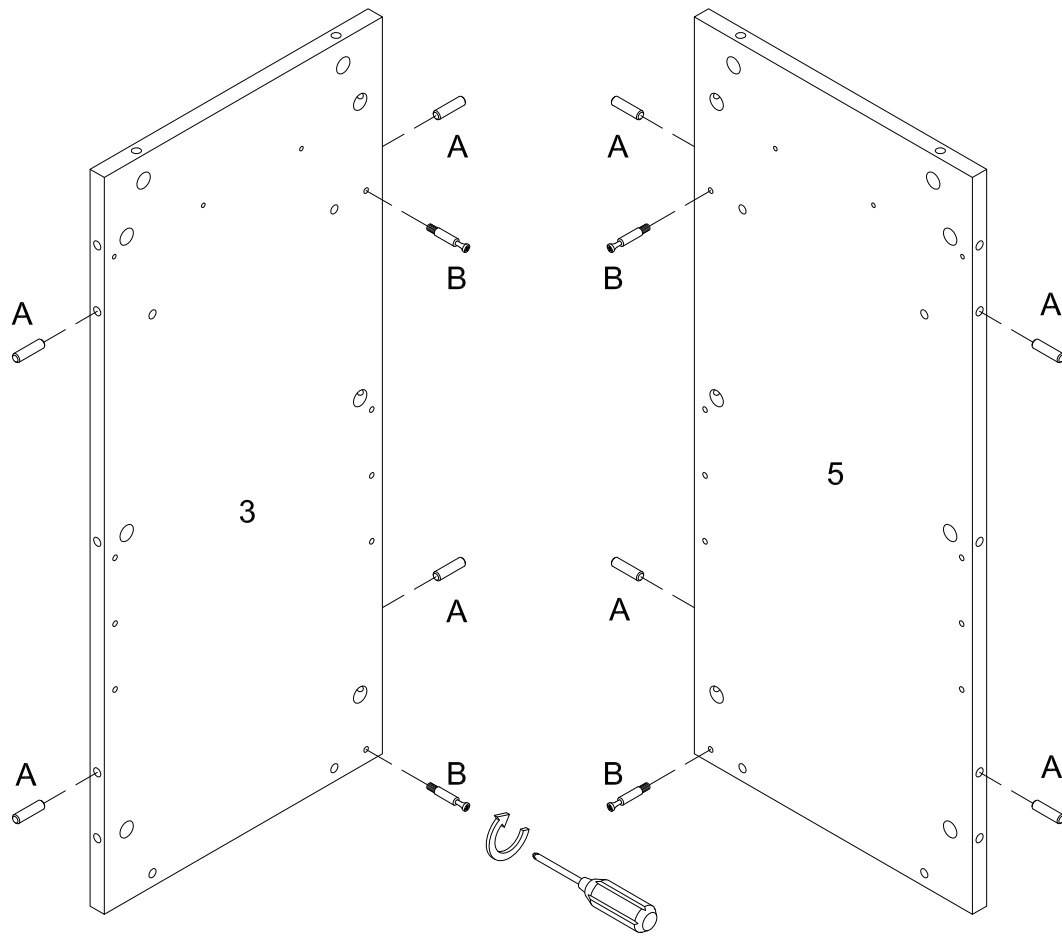

Insert wooden dowel (A) into parts (3,5) ,then using cam bolt (B) secure parts (3,5) with Philips head screwdriver as per diagram.

Step 6

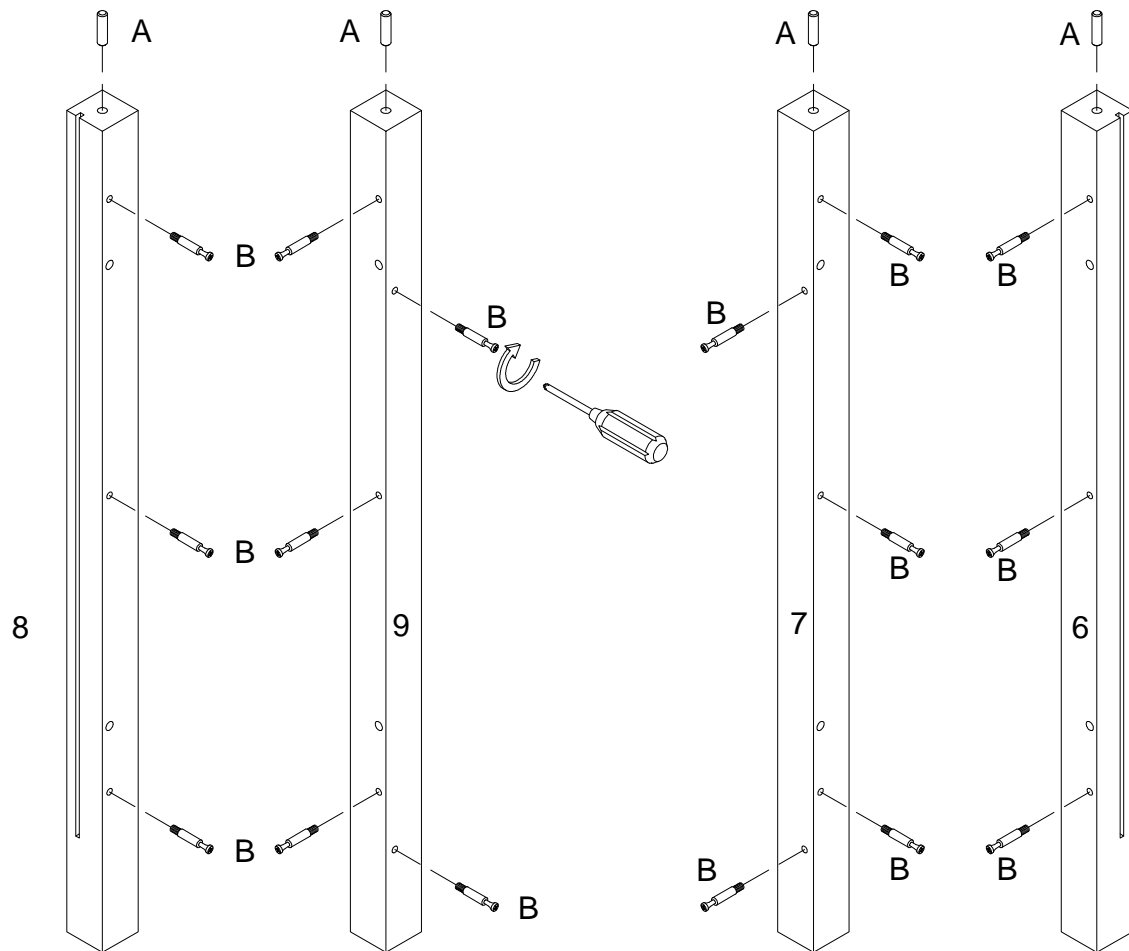

Insert wooden dowel (A) into parts (6,7,8,9) ,then using cam bolt (B) secure parts (6,7,8,9) with Philips head screwdriver as per diagram.

Step 7

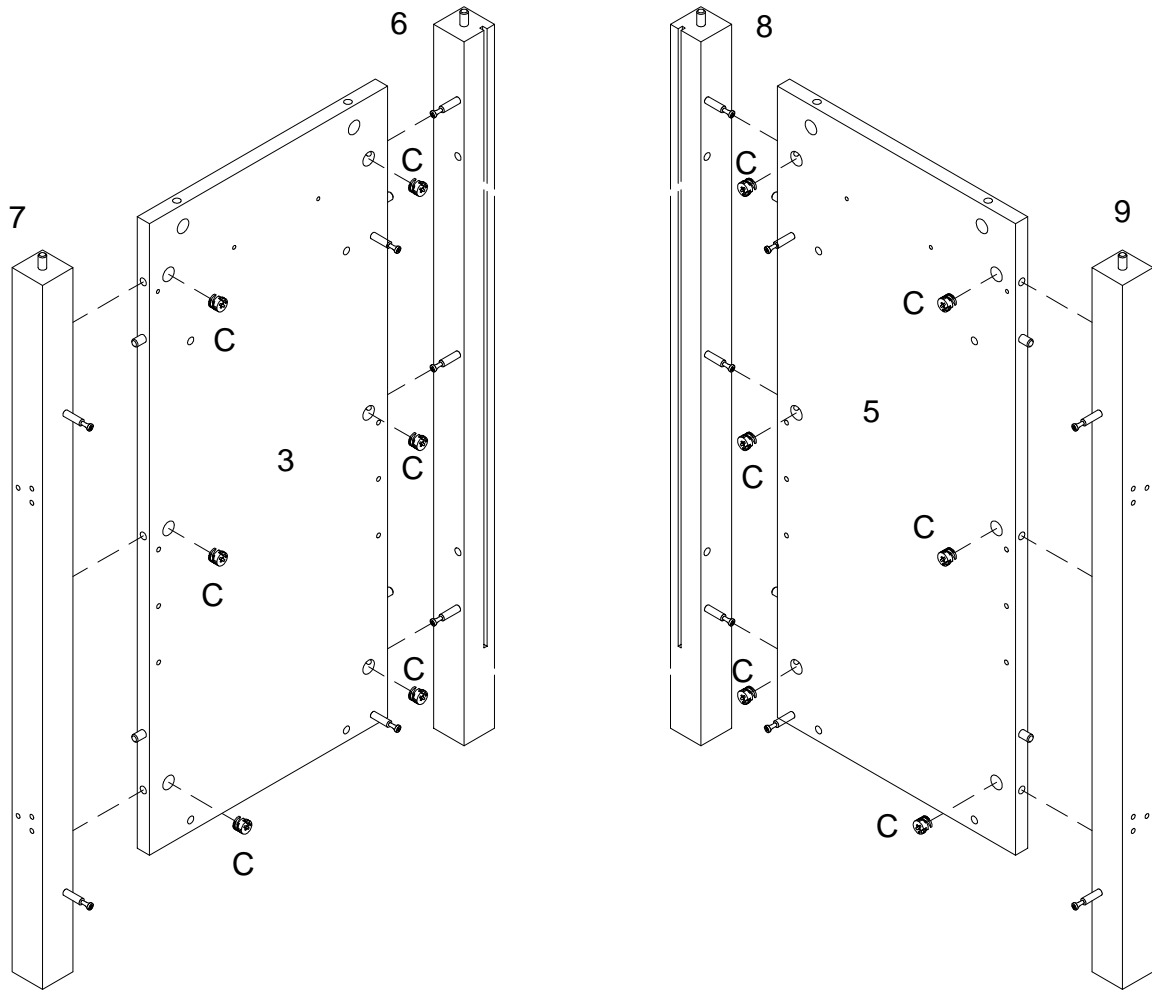
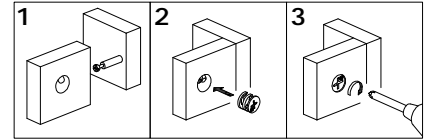

Using cam lock (C) secure parts (6,7,8,9) to parts (3,5) with Philips head screwdriver as per diagram.

Step 8

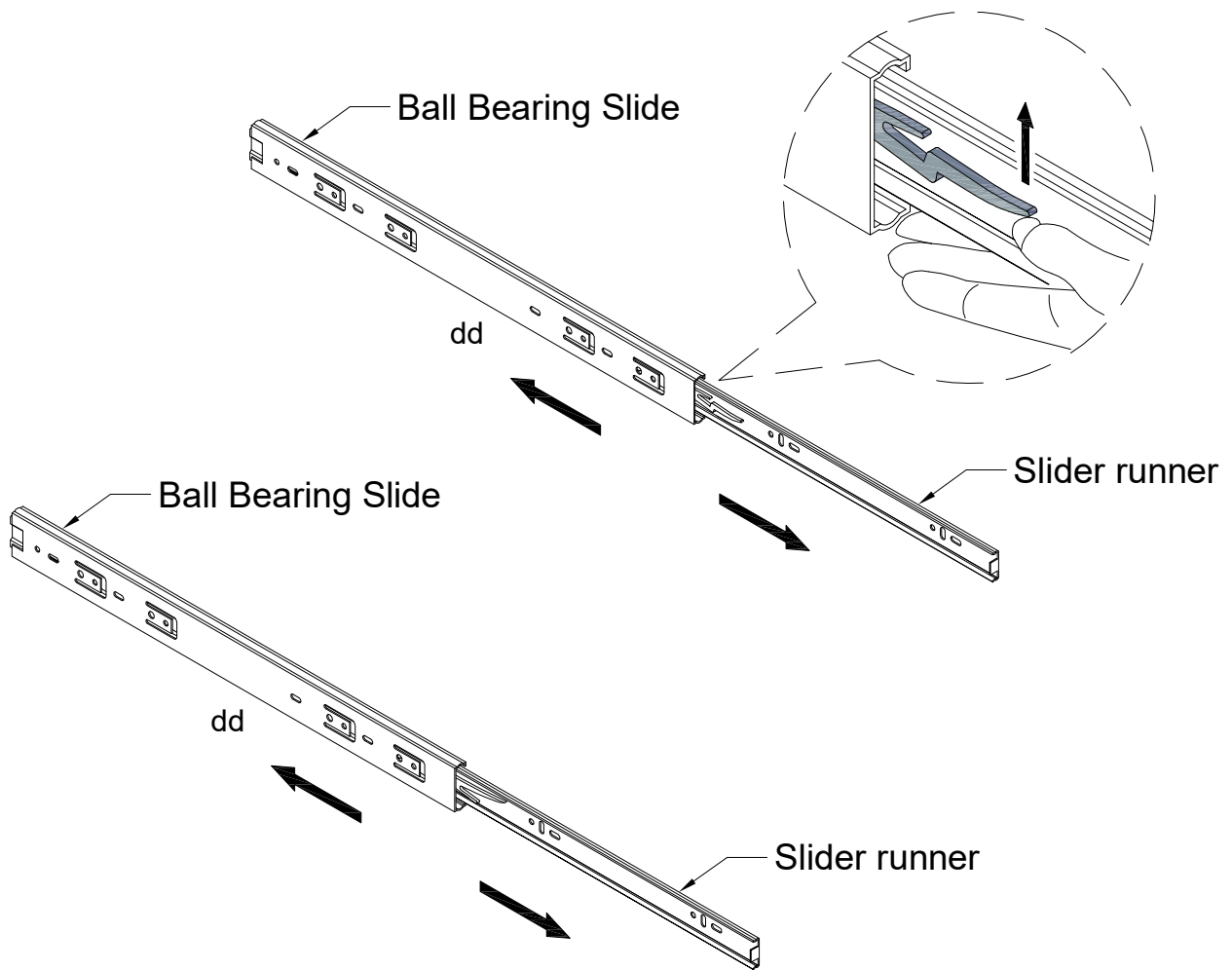

Pick up the Ball Bearing Slides (dd) and separate the slide Runner for the following Steps. Extend the Slide Runner all the way forward,press the plastic release lever of the ball bearing Slides up and pull the Slide Runner Complete out .

Step 9

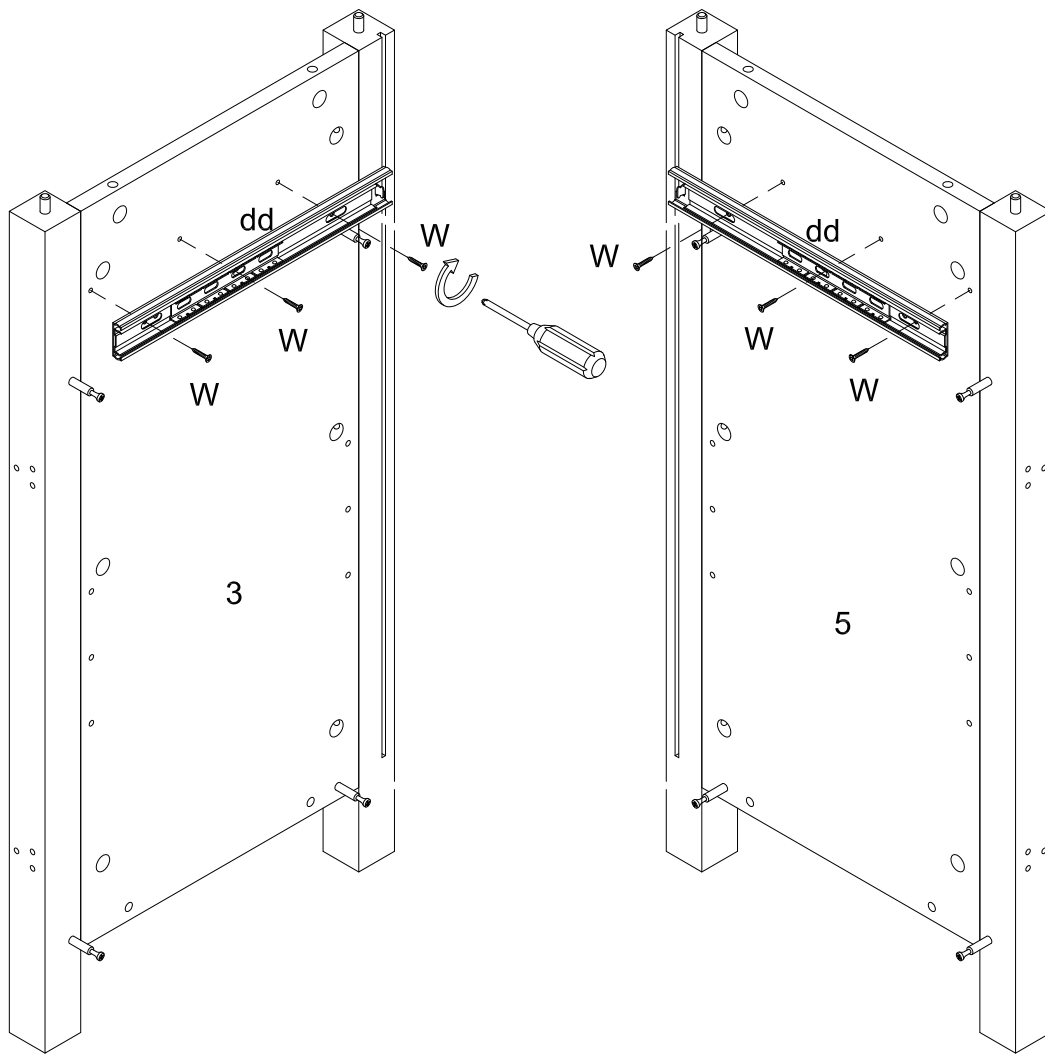

Using screw (W) secure drawer slider (dd) into parts (3,5) with Philips head screwdriver as per diagram.

Step 10

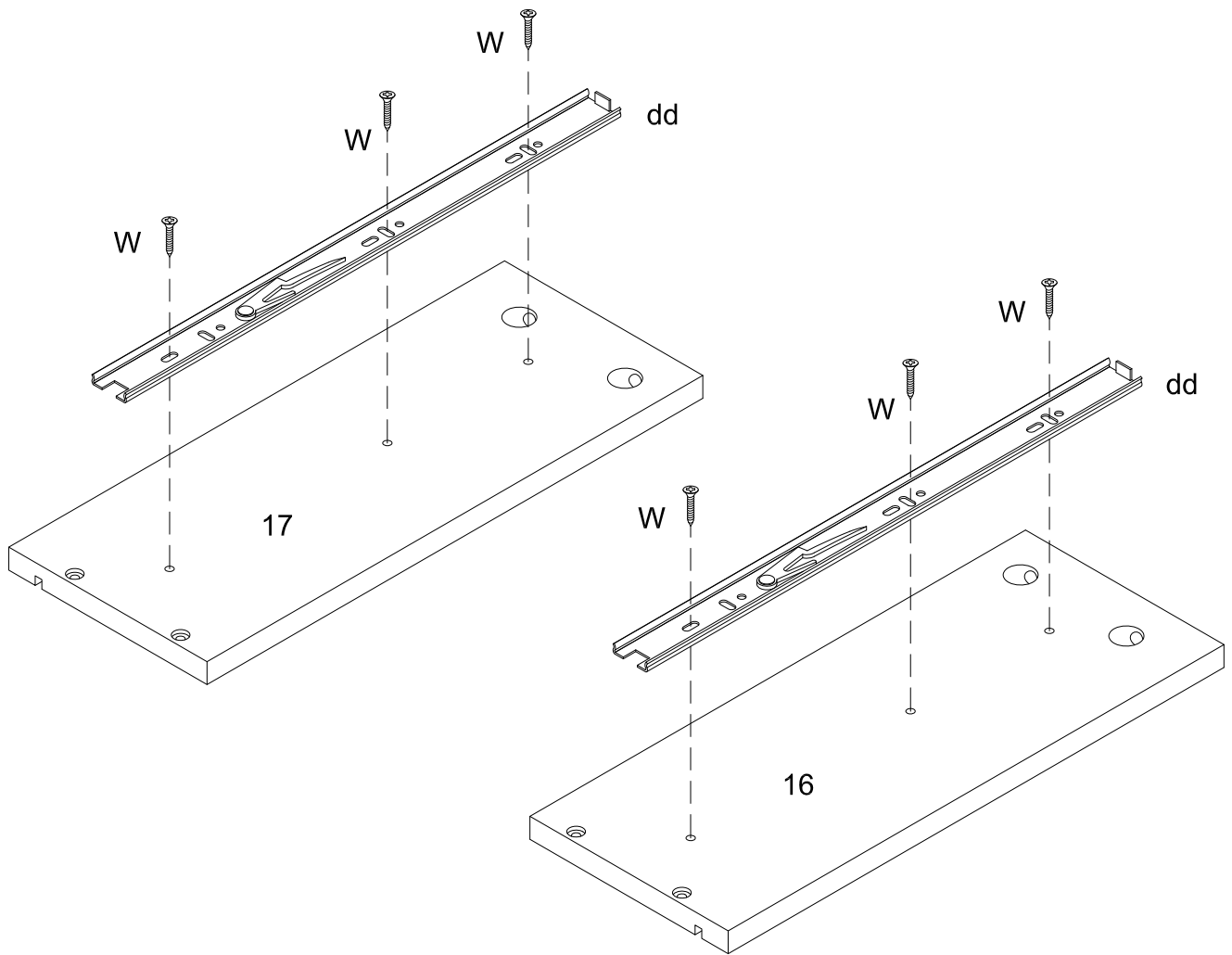

Using screw (W) secure drawer slider (dd) into parts (16,17) with Philips head screwdriver as per diagram.

Step 11

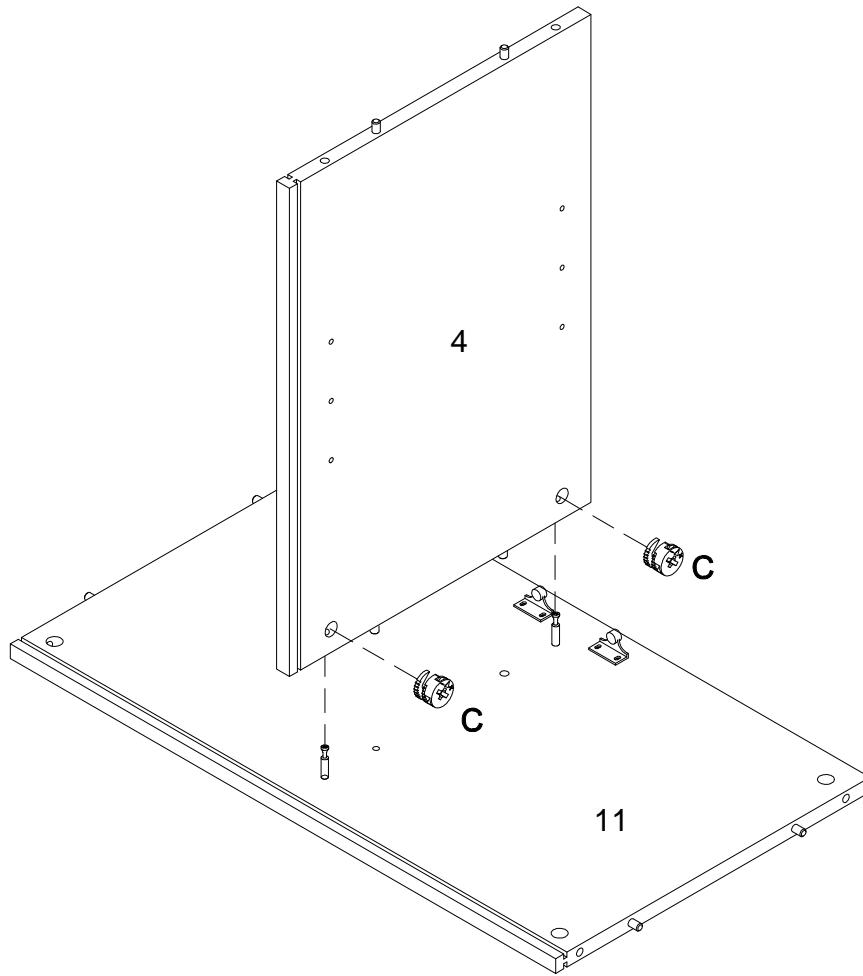
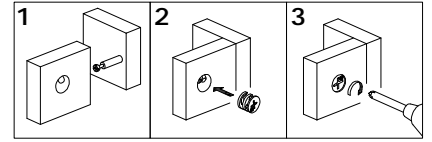

Using cam lock (C) secure part (4) into part (11) with Philips head screwdriver as per diagram.

Step 12

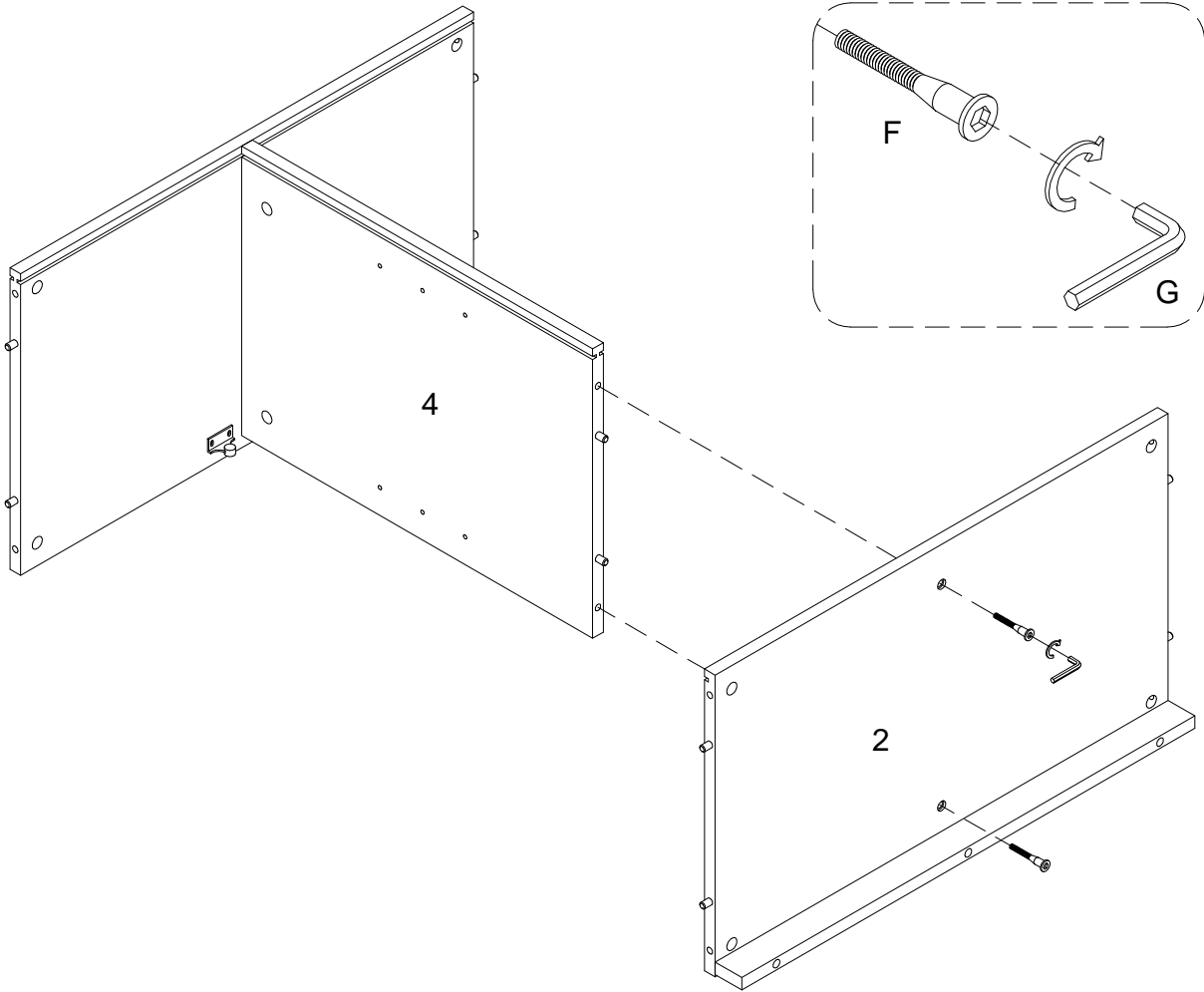

Using screw (F) secure part (2) into part (4) with hex key (G) as per diagram.

Step 13

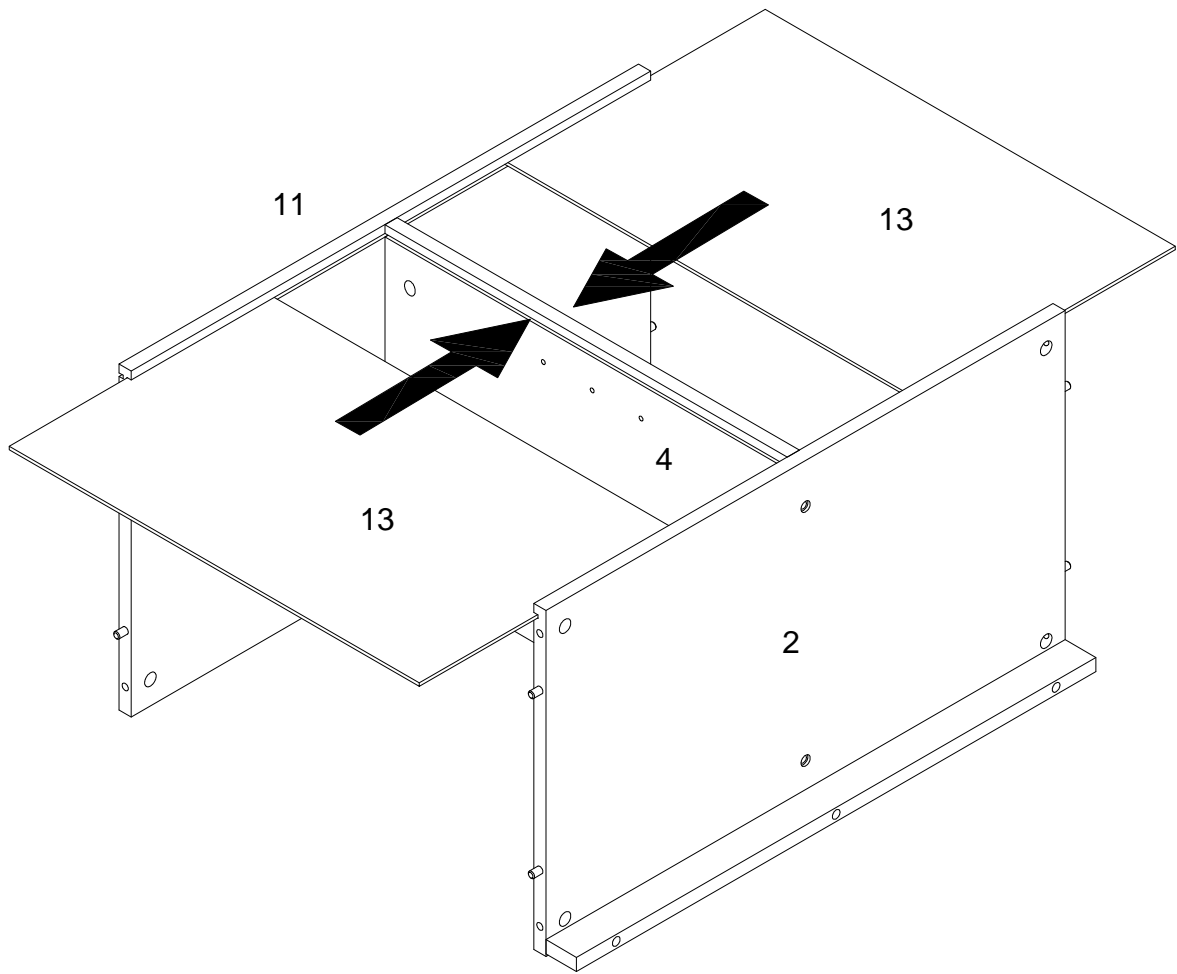

Put part (13) into parts (2,4,11) as per diagram.

Step 14

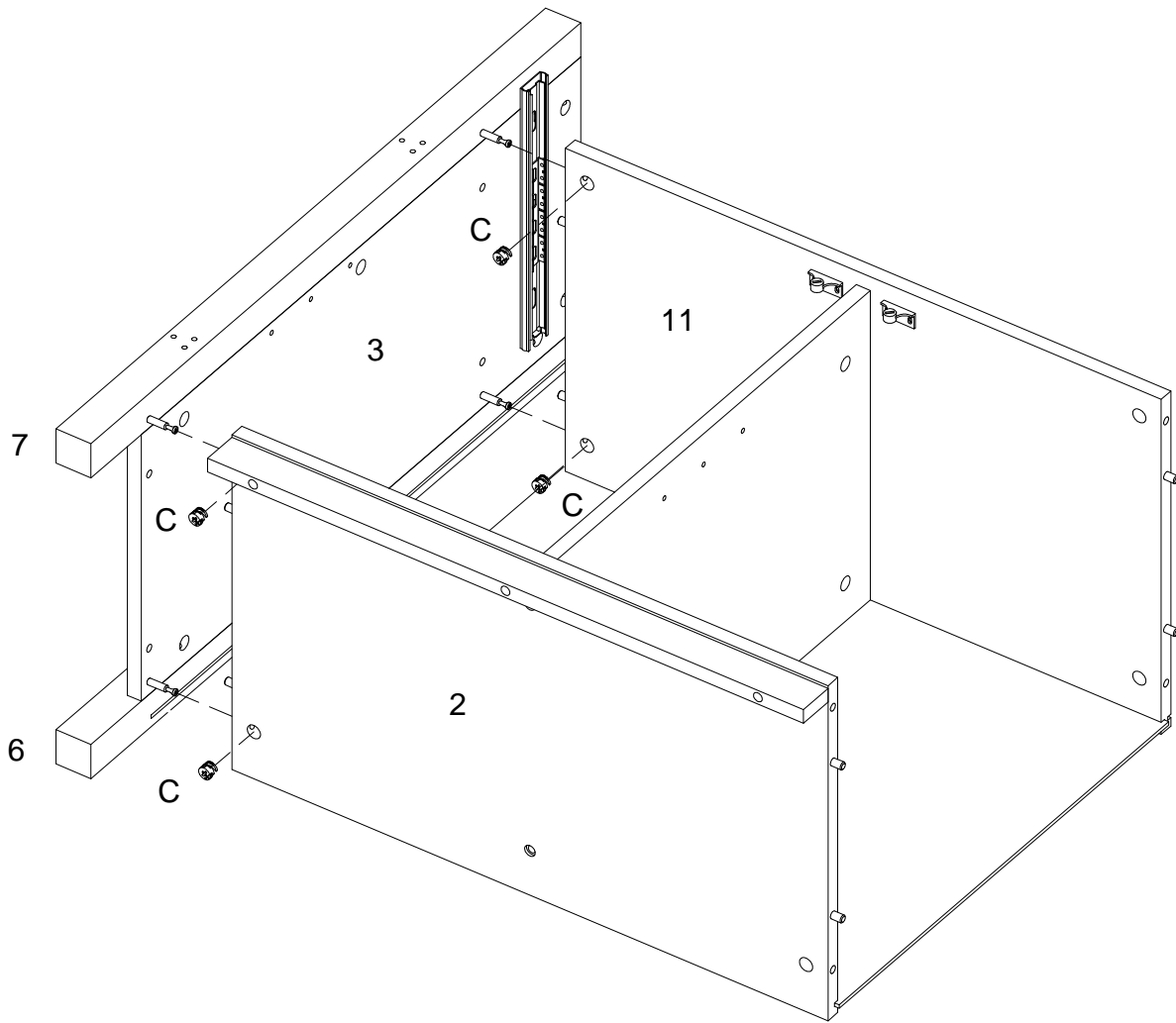
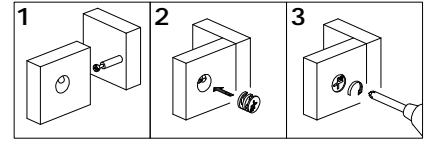

Using cam lock (C) secure parts (3,7) into parts (2,11) with Philips head screwdriver as per diagram.

Step 15

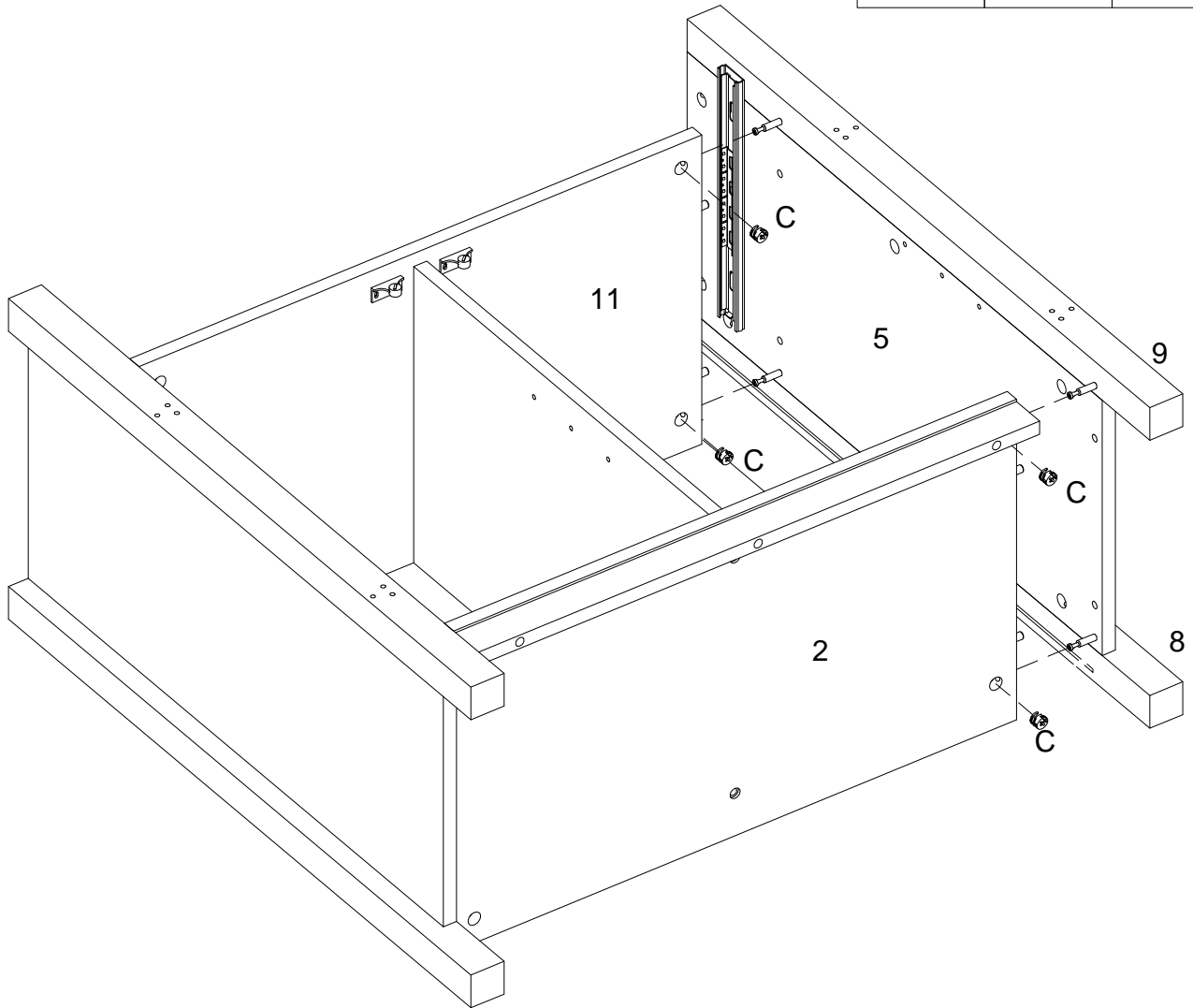
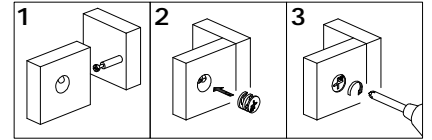

Using cam lock (C) secure parts (5,9) into parts (2,11) with Philips head screwdriver as per diagram.

Step 16

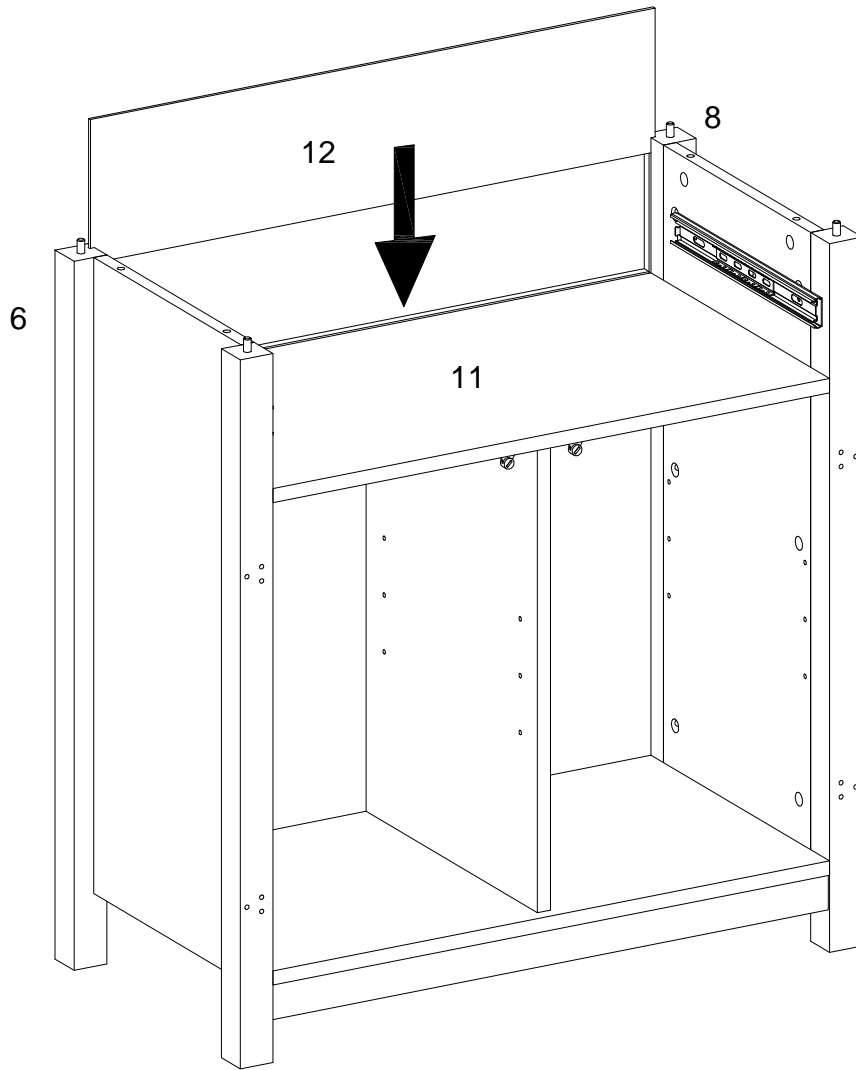

Put part (12) into parts (6,8,11) as per diagram.

Step 17

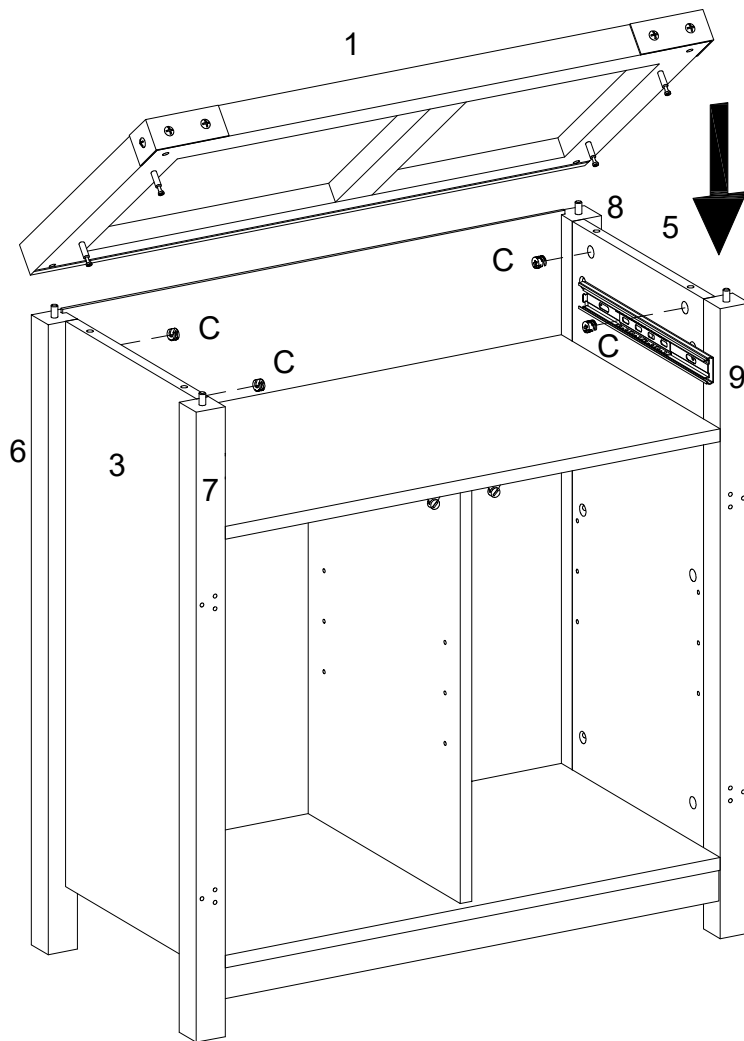
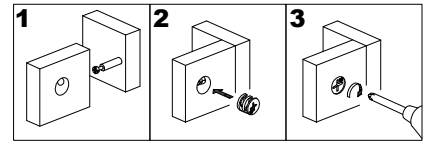

Using cam lock (C) secure part (1) into parts (3,5,6,7,8,9) with Philips head screwdriver as per diagram.

Step 18

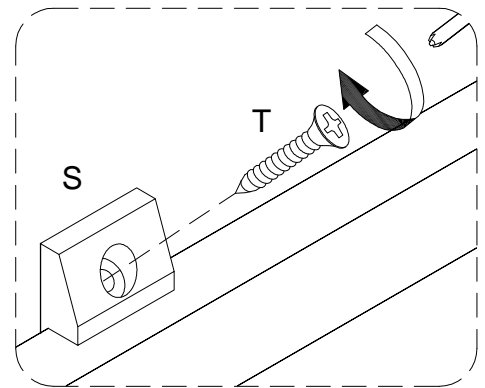
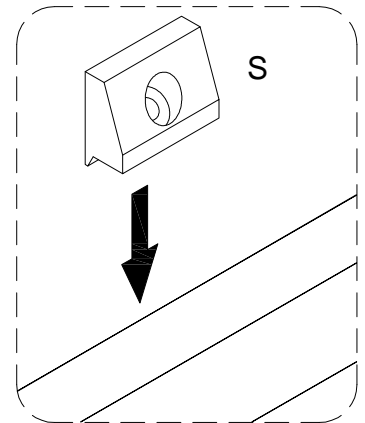
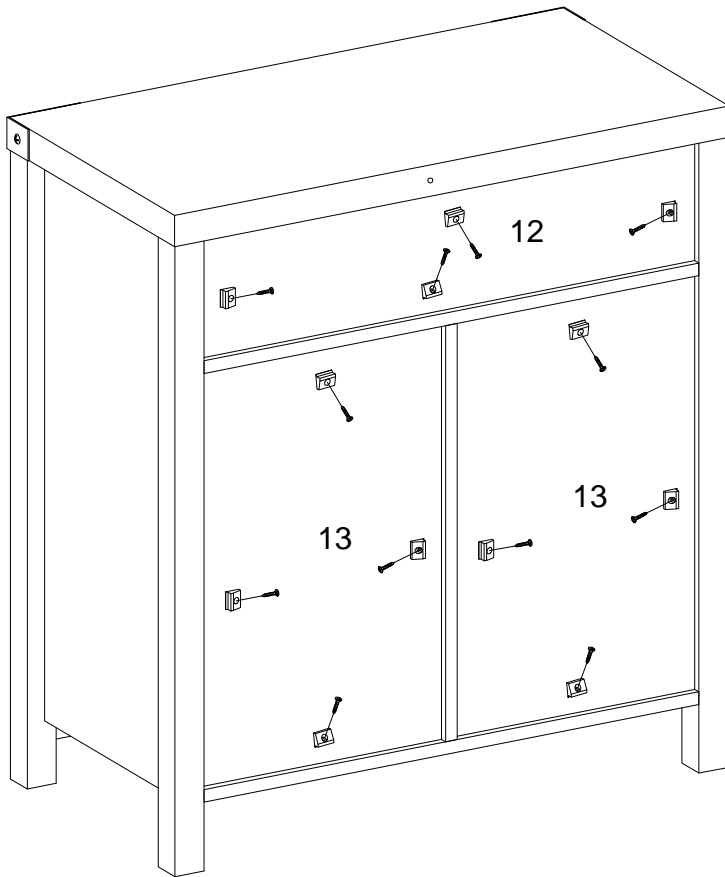

Using screw (T) secure plastic wedge (S) into parts (12,13) with Philips head screwdriver as per diagram.

Step 19

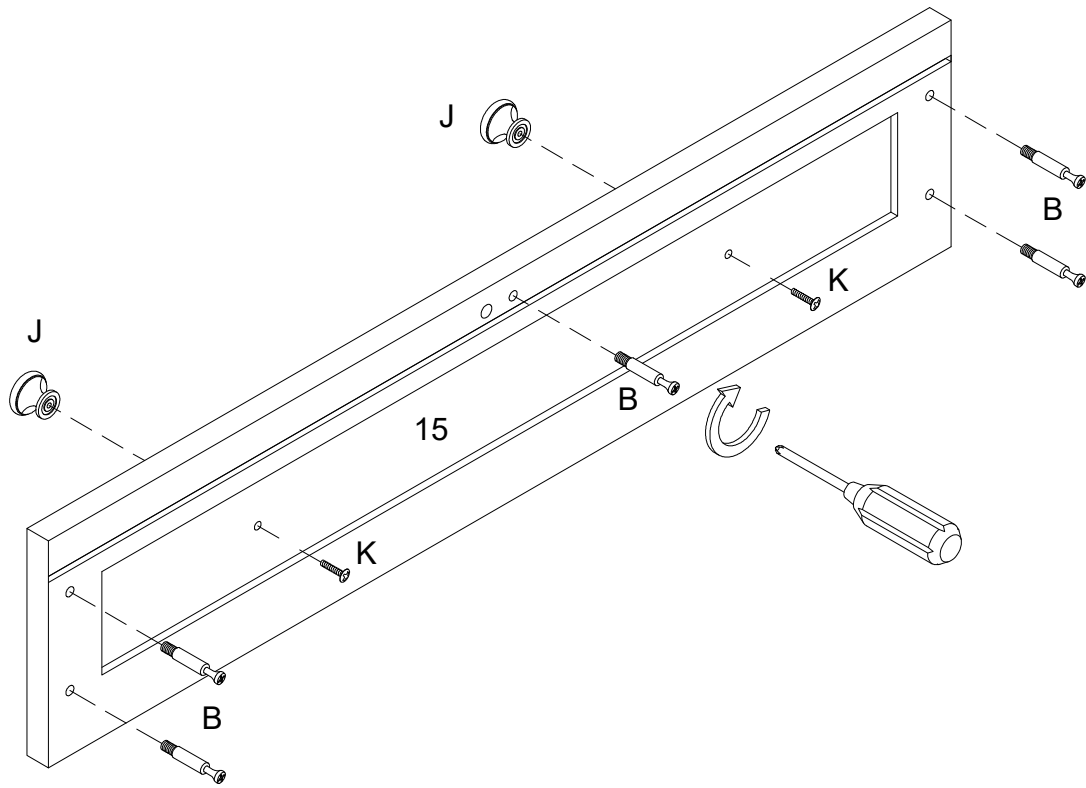

Using cam bolt (B) secure part (15) ,then using handle bolt (K) secure handle (J) into part (15) with Philips head screwdriver as per diagram.

Step 20

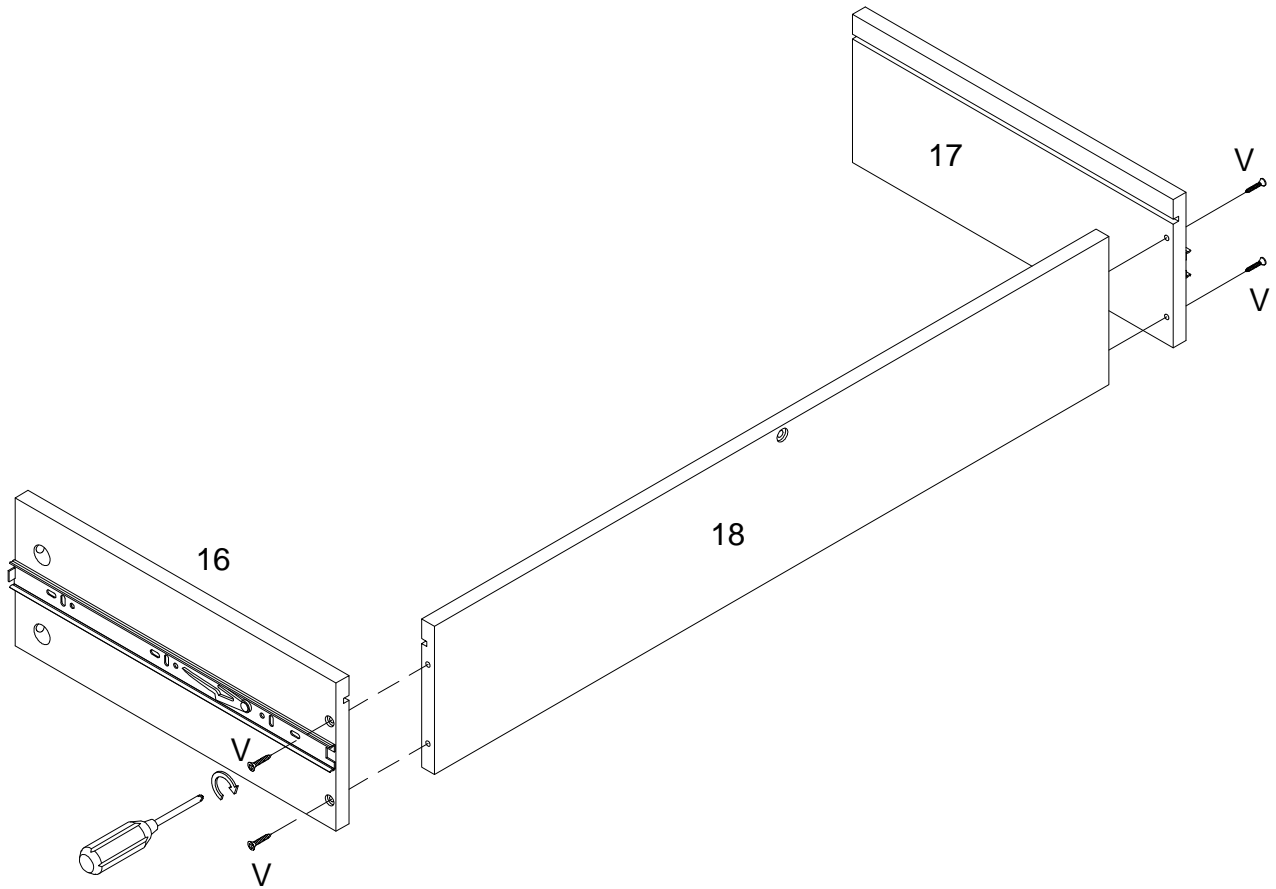

Using screw (V) secure parts (16,17) into part (18) with Philips head screwdriver as per diagram.

Step 21

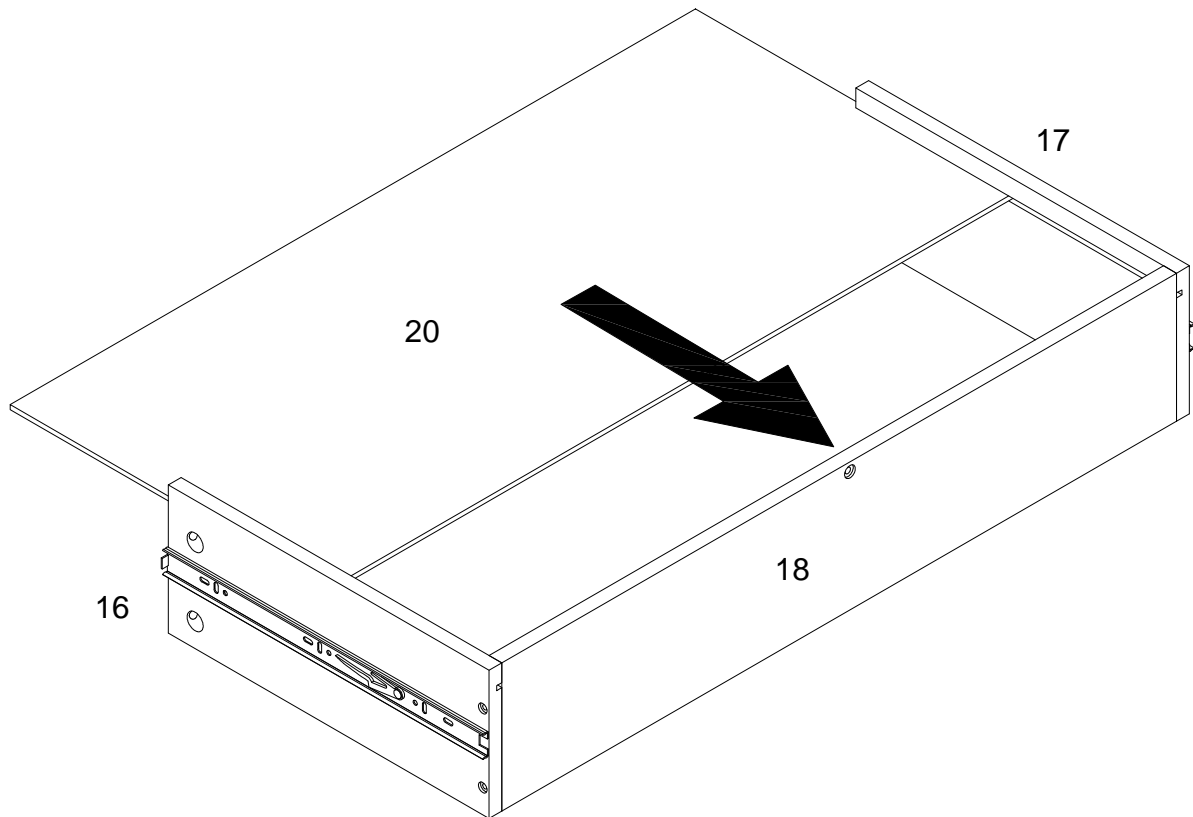

Put part (20) into parts (16,17,18) as per diagram.

Step 22

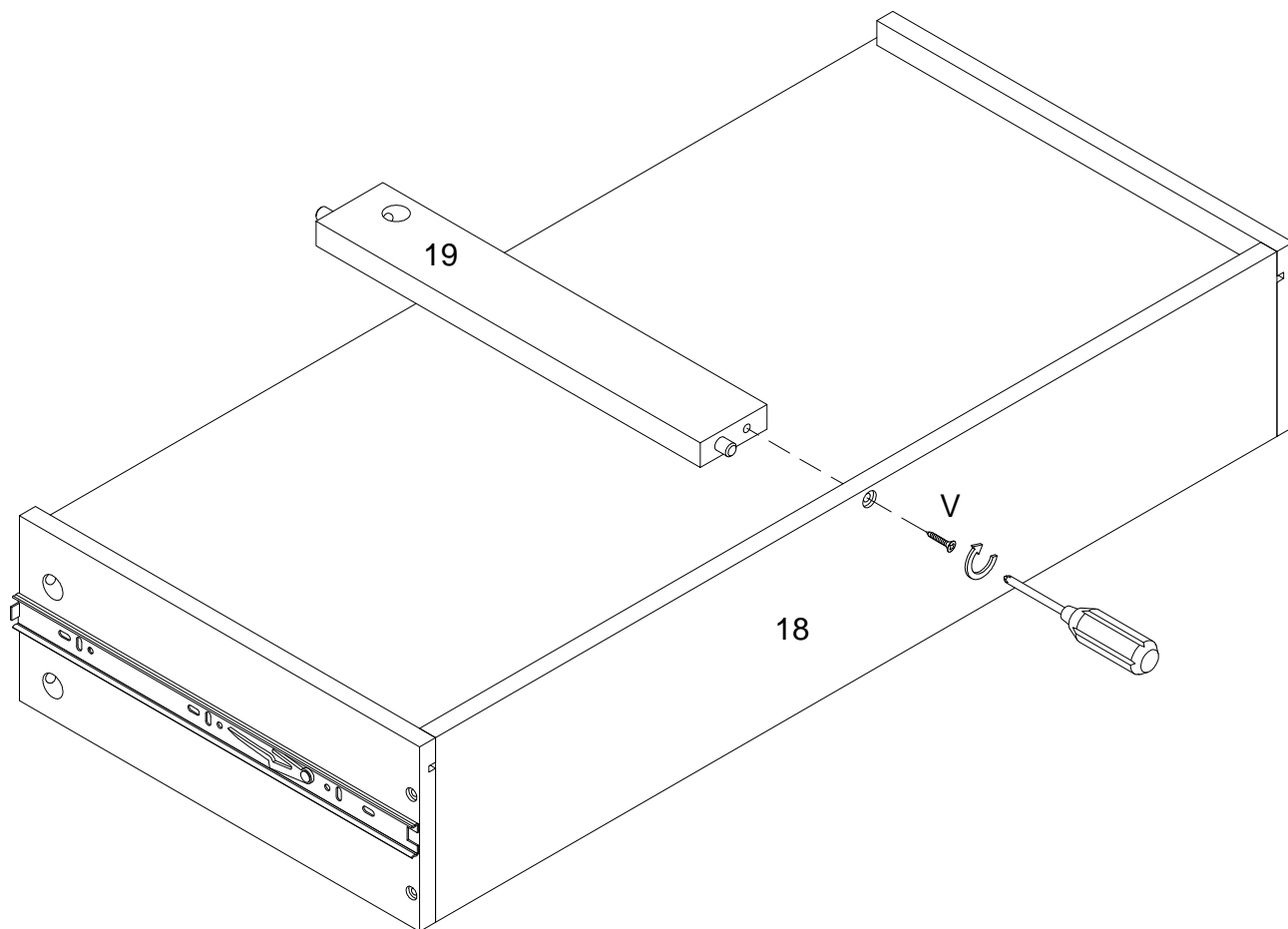

Using screw (V) secure part(19) into part (18) with Philips head screwdriver as per diagram.

Step 23

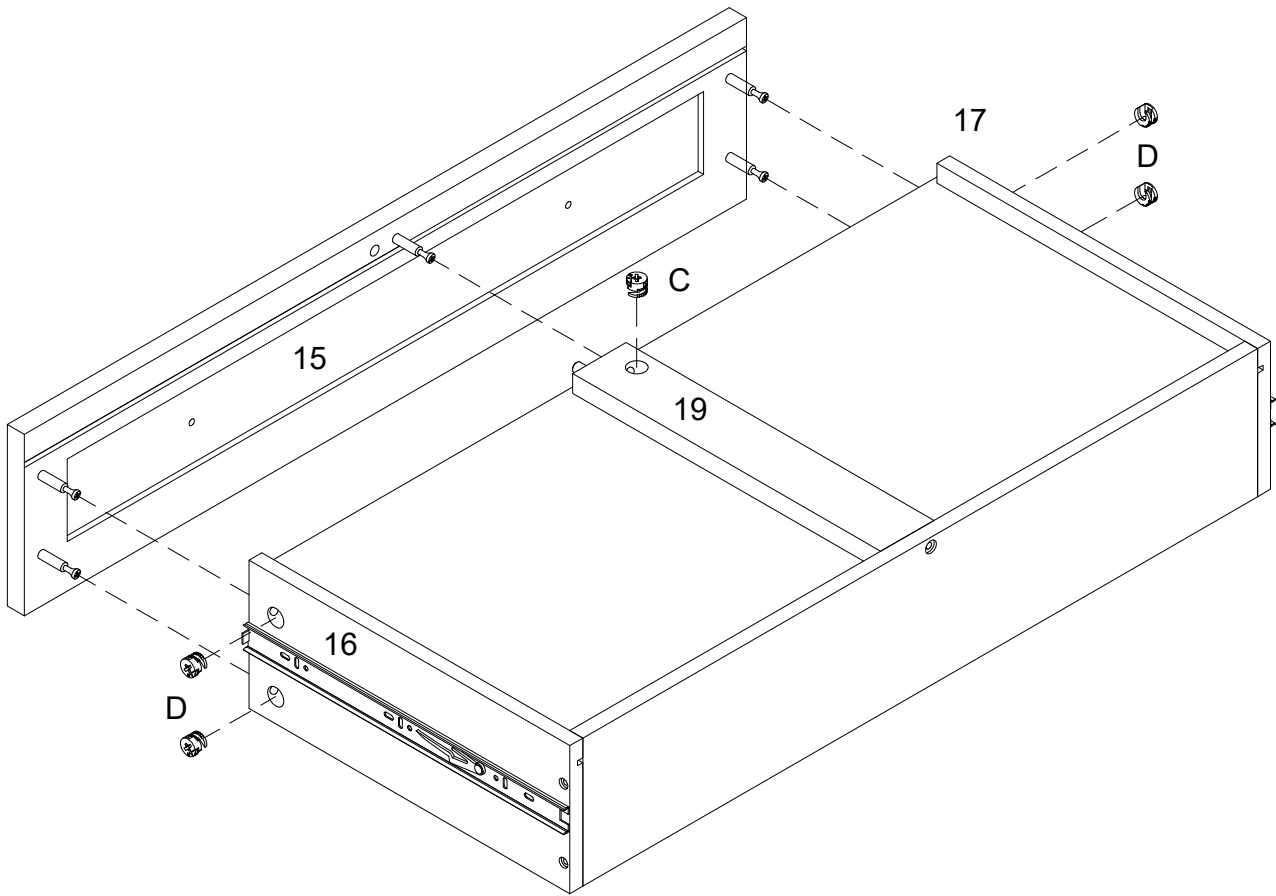
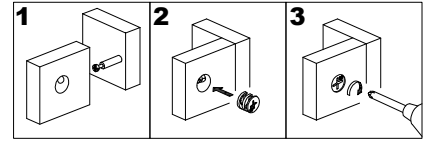

Using cam lock (C) secure part (15) into part (19), then using cam lock (D) secure part (15) into parts (16,17) with Philips head screwdriver as per diagram.

Step 24

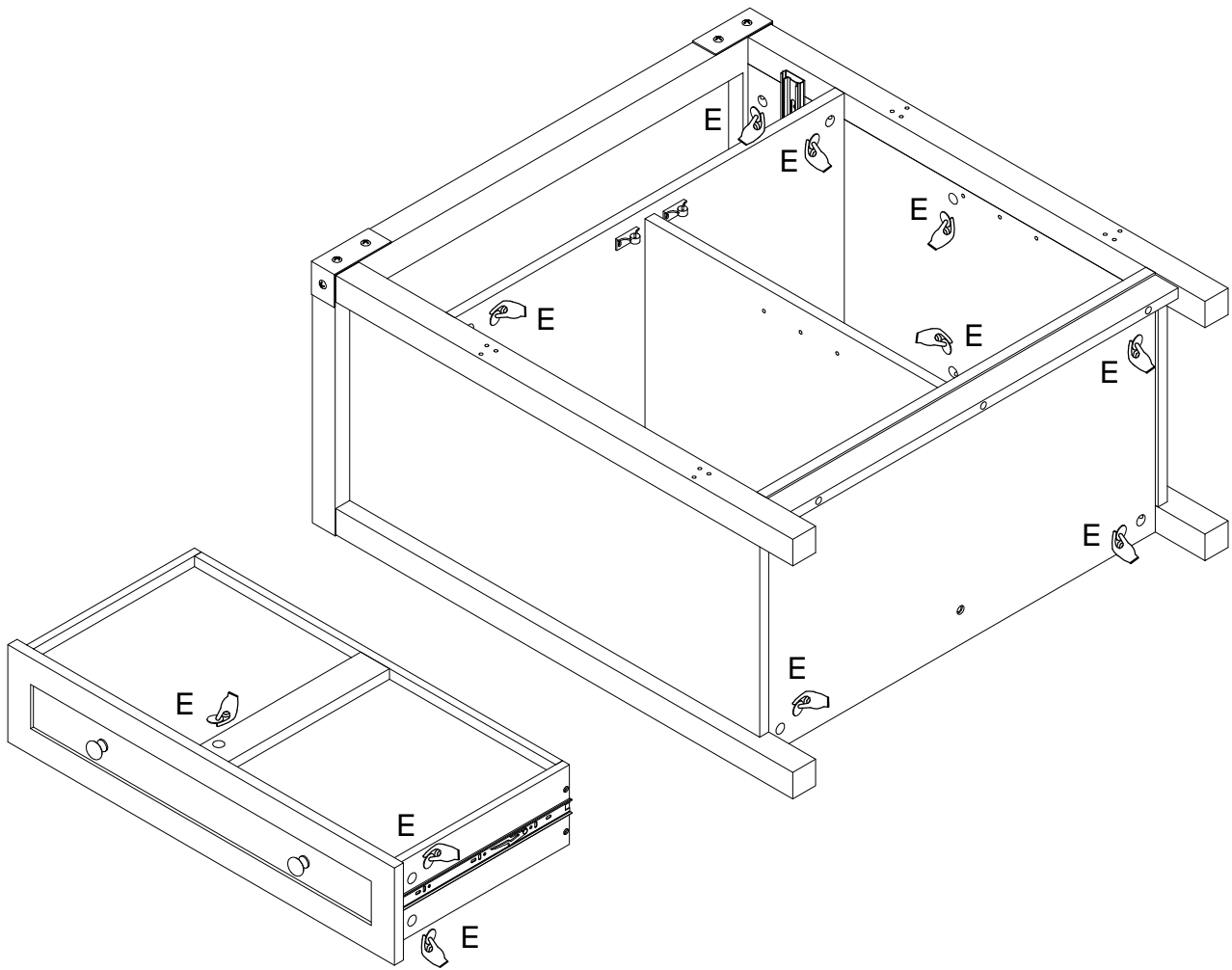

Place sticker (E) cover the holes as per diagram.

Step 25

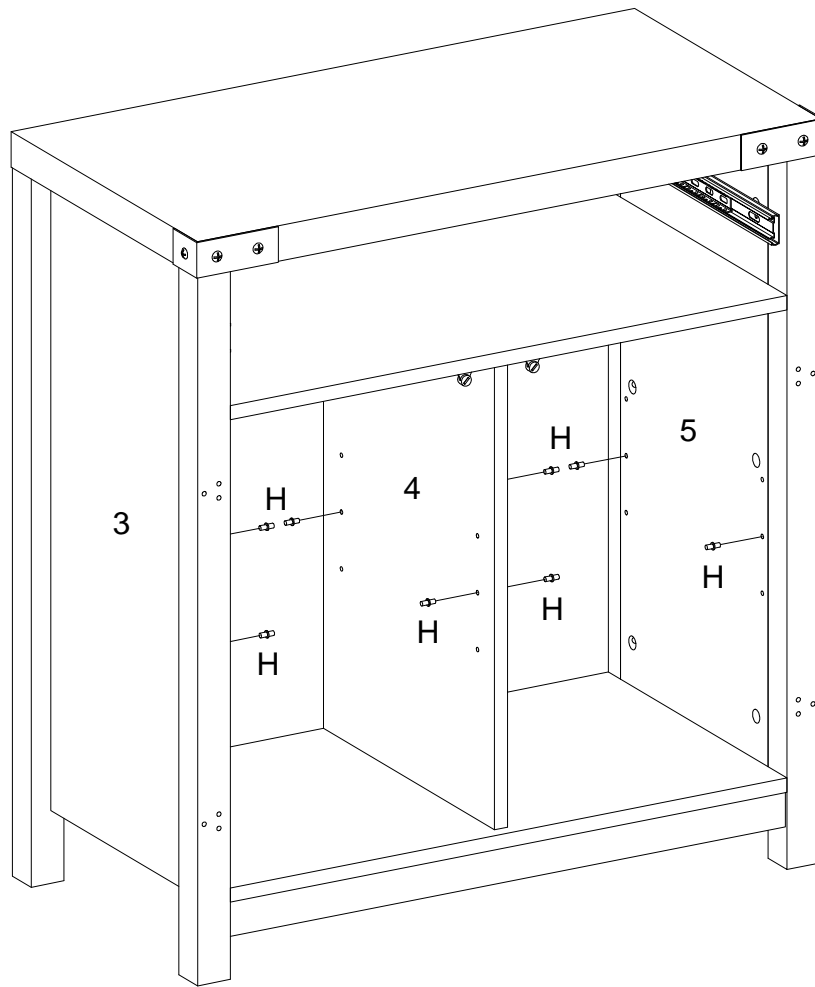

Insert shelf support pin (H) into parts (3,4,5) as per diagram.

Step 26

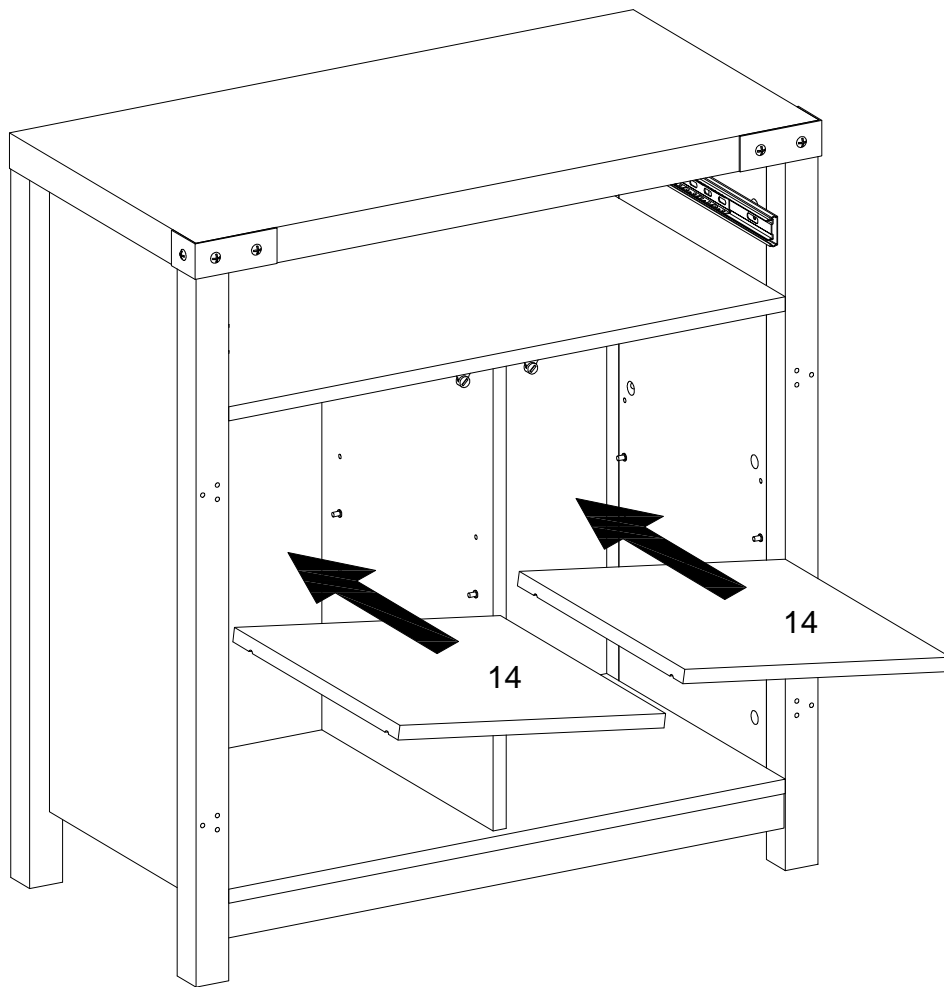

Put part (14) as per diagram.

Step 27

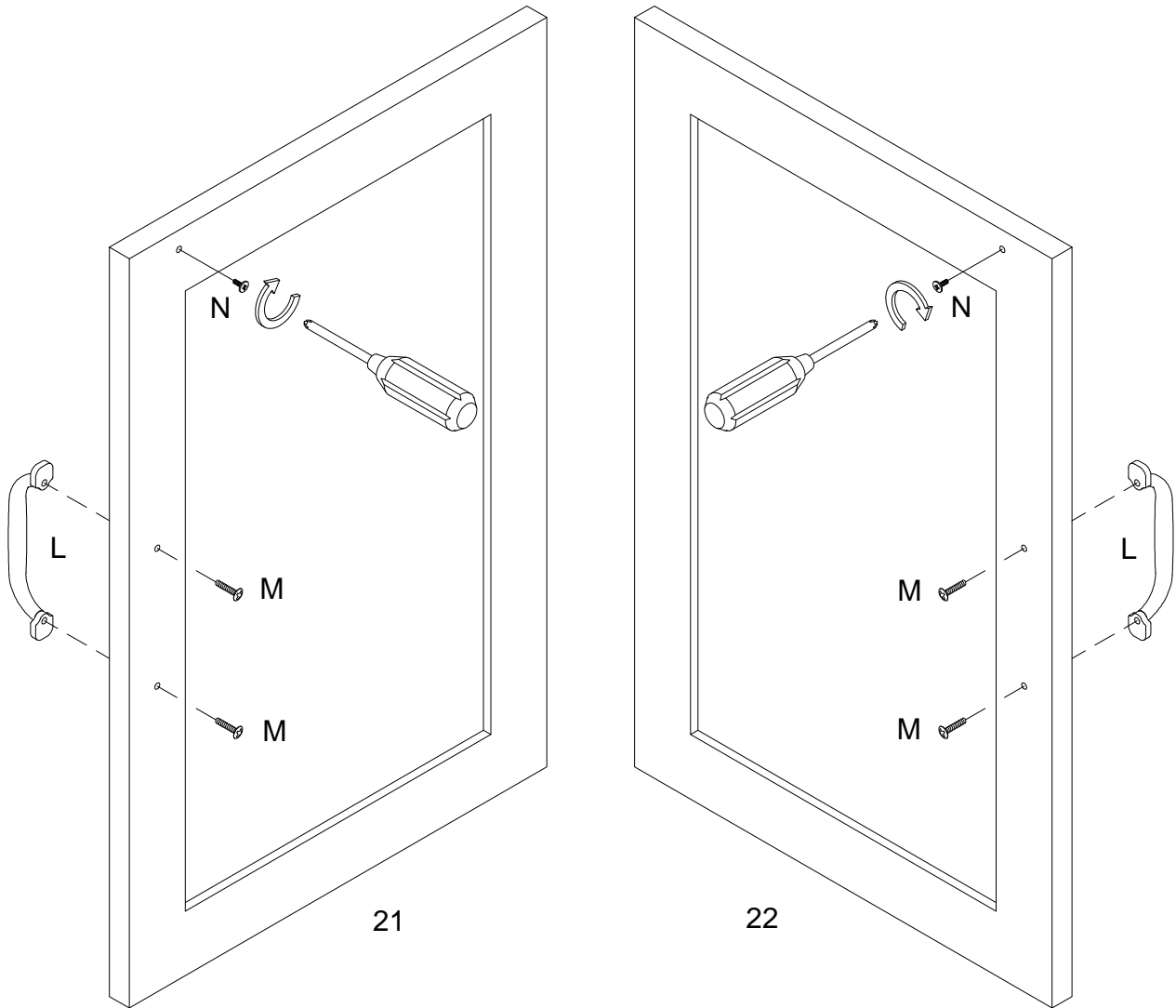

Using bolt (N) secure part(21,22) , then using handle bolt (M) secure part(21,22) into handle (L) with Philips head screwdriver as per diagram.

Step 28

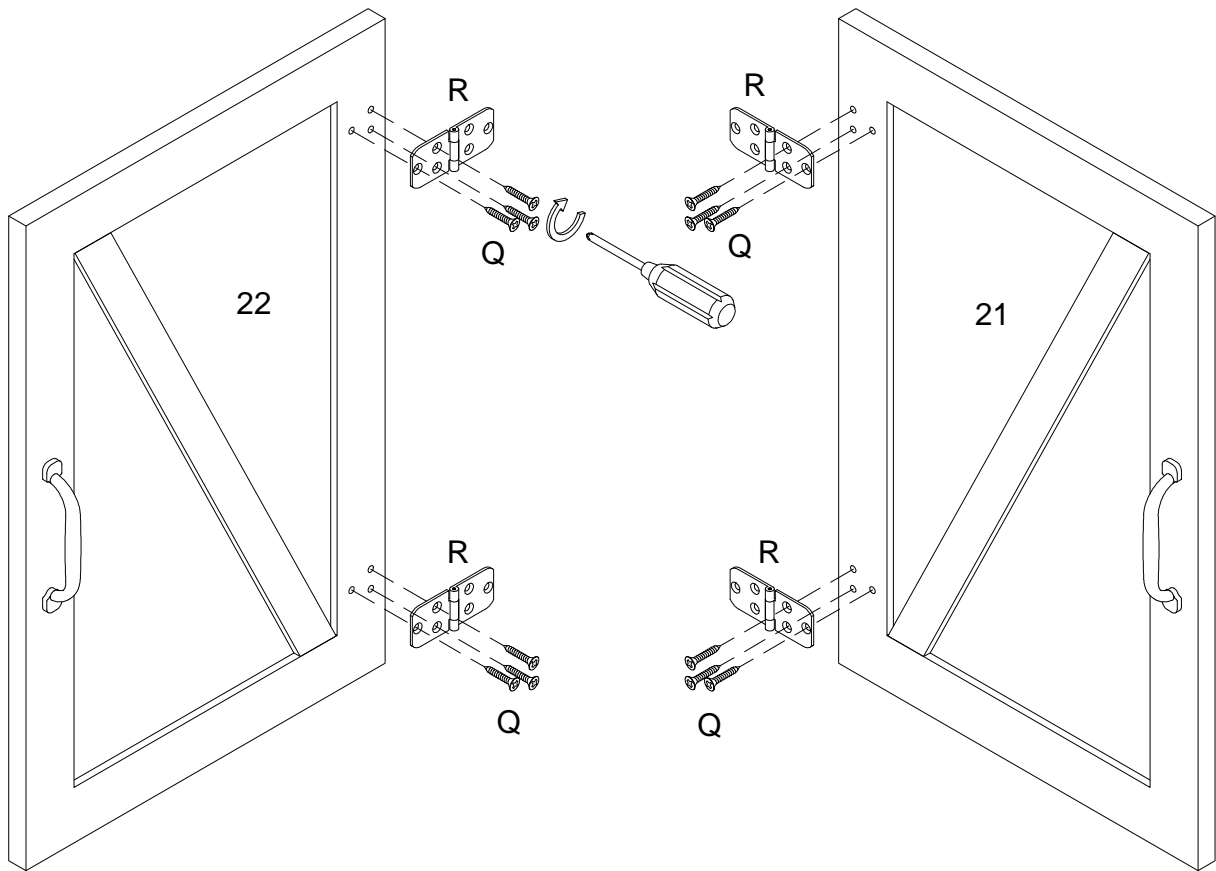

Using screw (Q) secure hinge (R) into parts (21,22) with Philips head screwdriver as per diagram.

Step 29

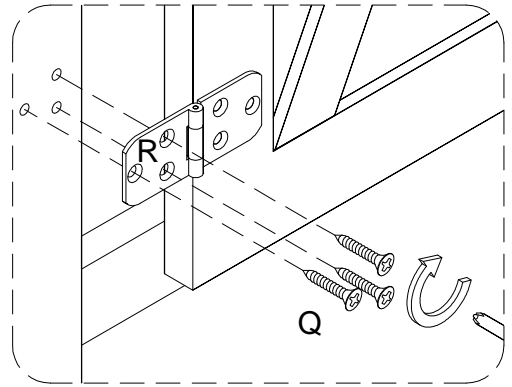
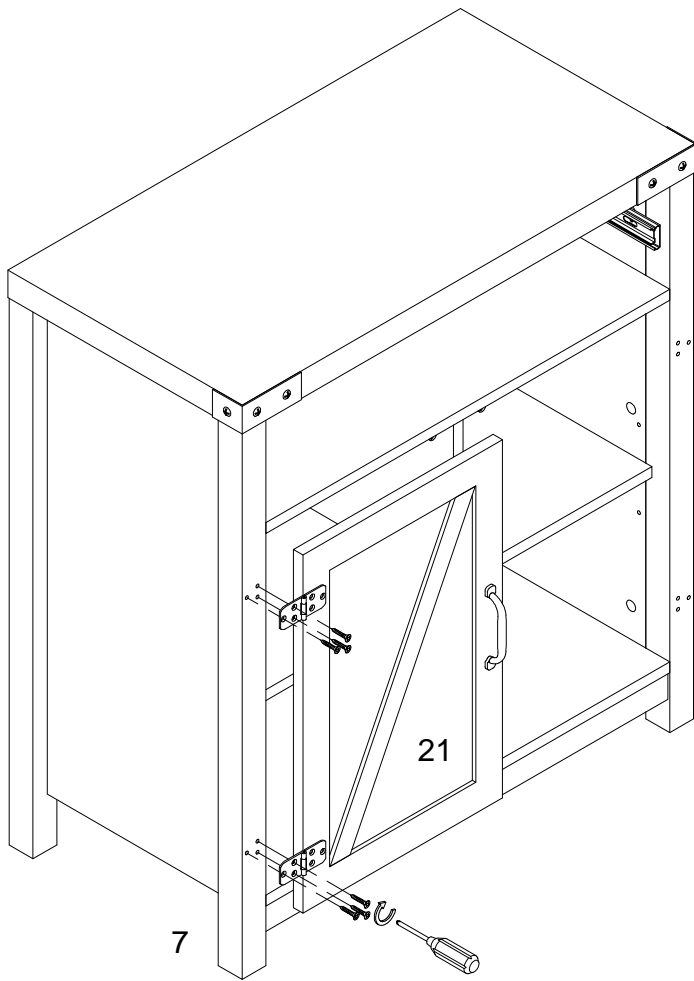

Using screw (Q) secure hinge (R) into part (7) with Philips head screwdriver as per diagram.

Step 30

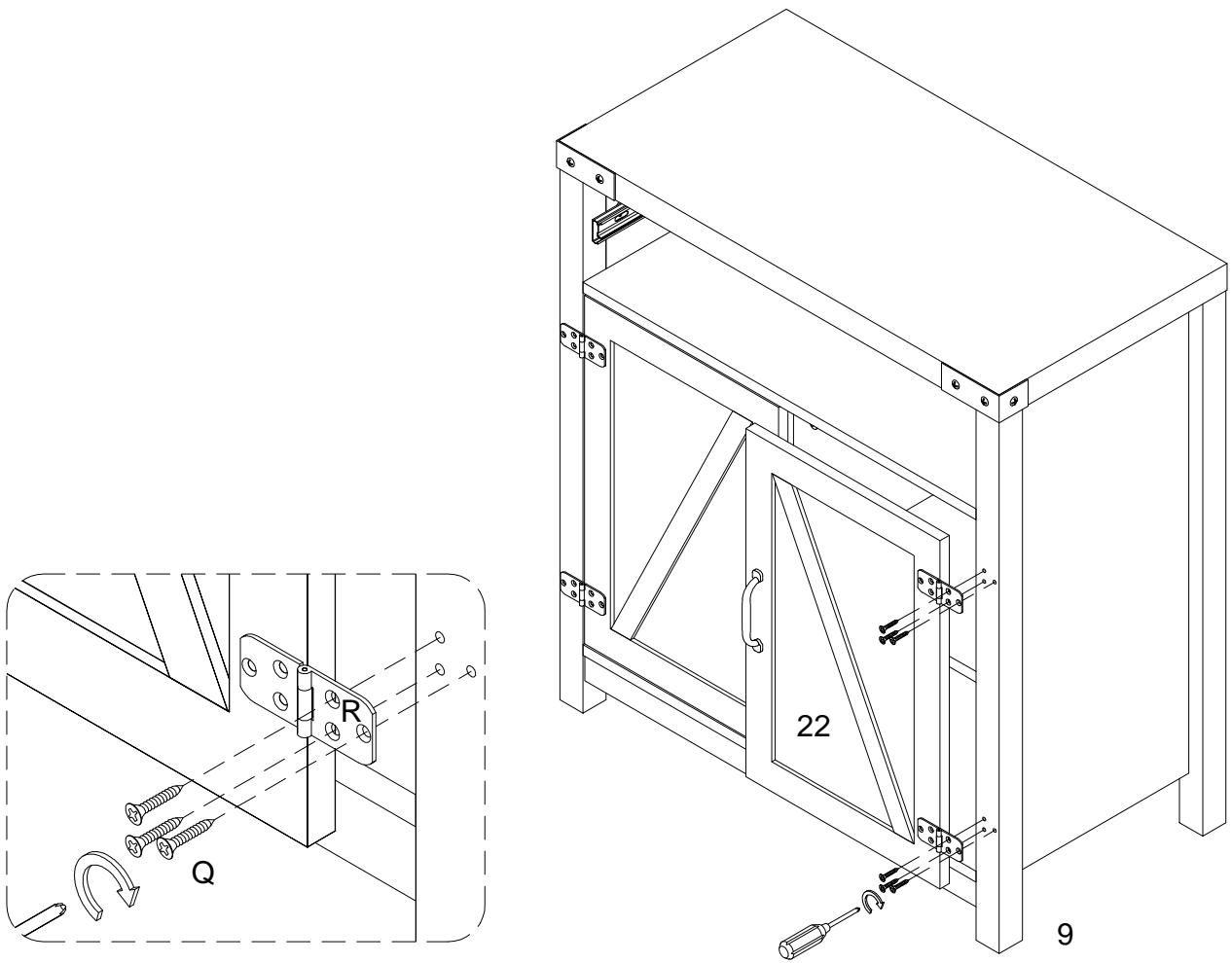

Using screw (Q) secure hinge (R) into parts (9) with Philips head screwdriver as per diagram.

Step 31

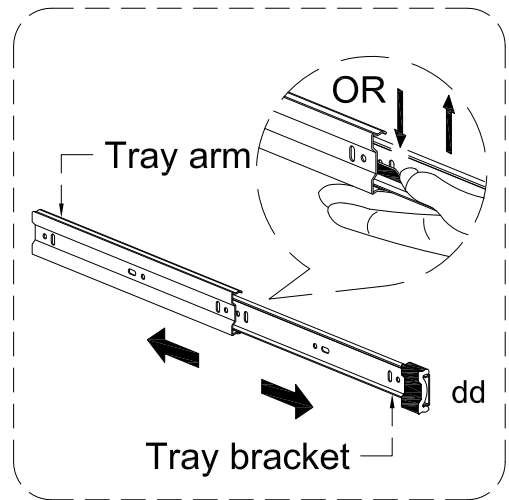
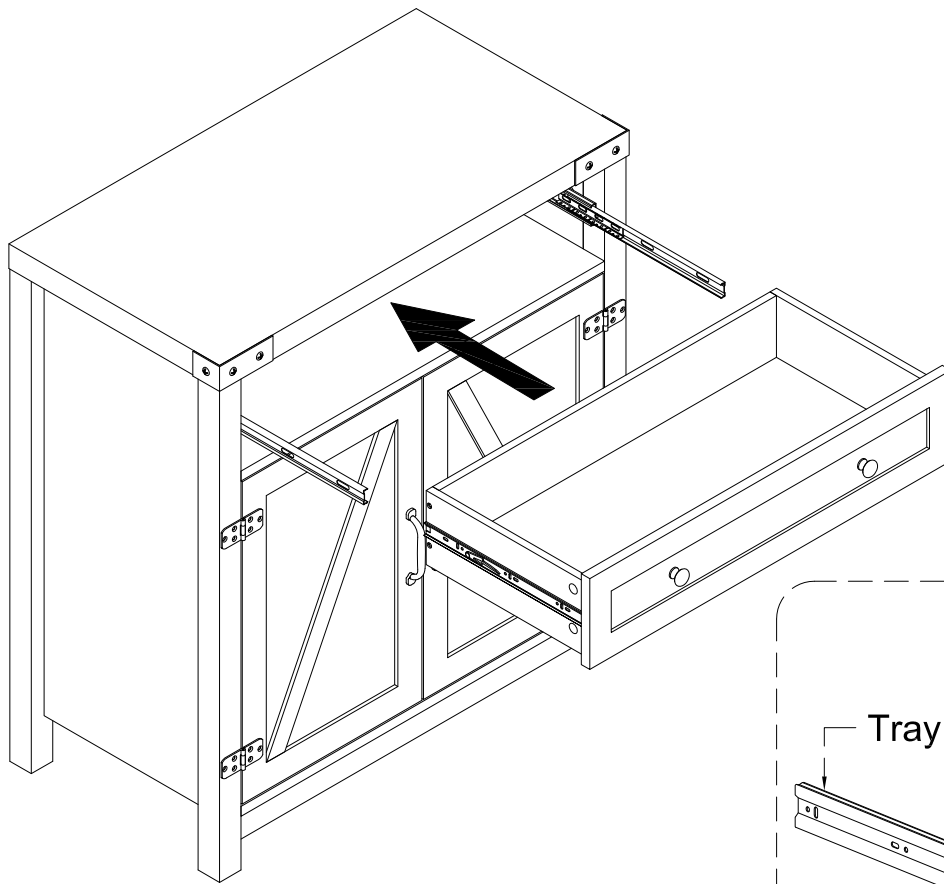

Put tray bracket (dd) into tray arm and put whole drawer into cabinet as per diagram.

Step 32

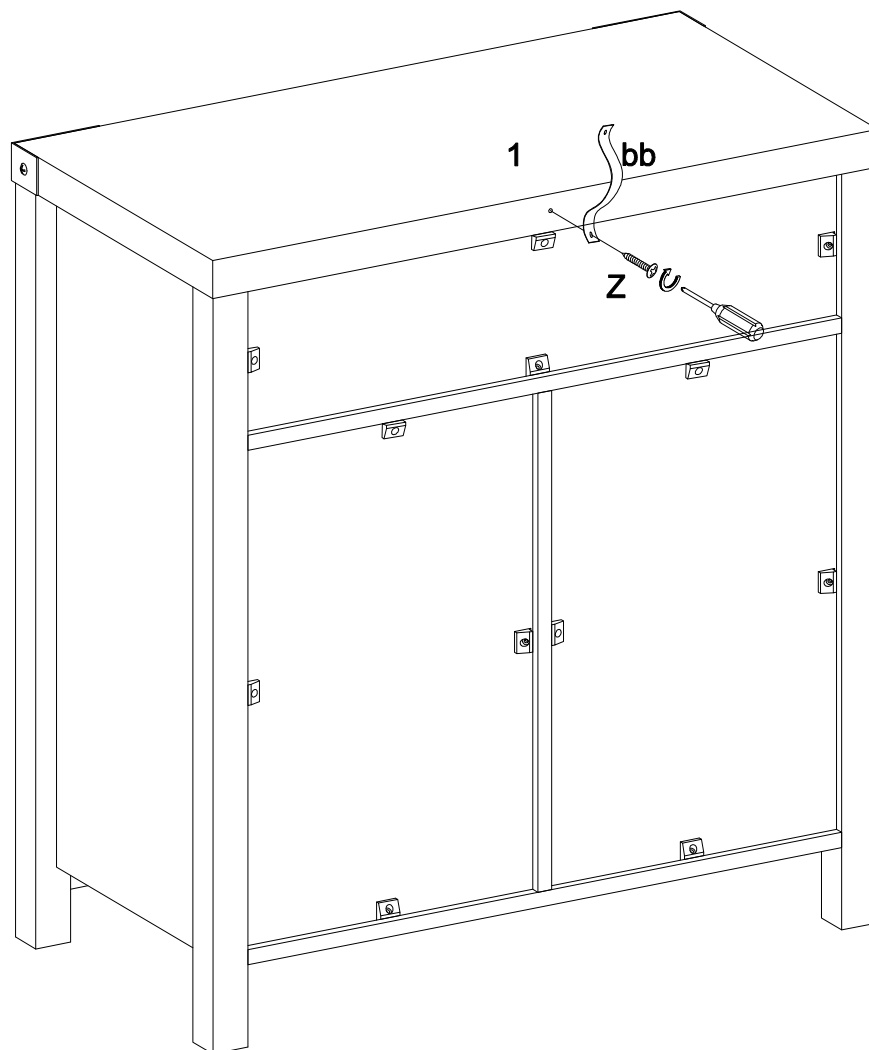

Using screw (Z) secure velcro strap (bb) into part (1) with Philips head screwdriver as per diagram.

Step 33

WARNING

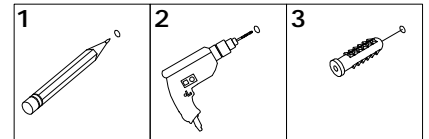

Serious or fatal injuries can occur from furniture tipping over. To prevent the furniture from tipping over we recommend that it is permanently fixed to the wall. Wall anchor and hardware are included with this product. Please make sure hardware is suitable for your walls before installing, as different wall materials may require different types of anchors.

Wall

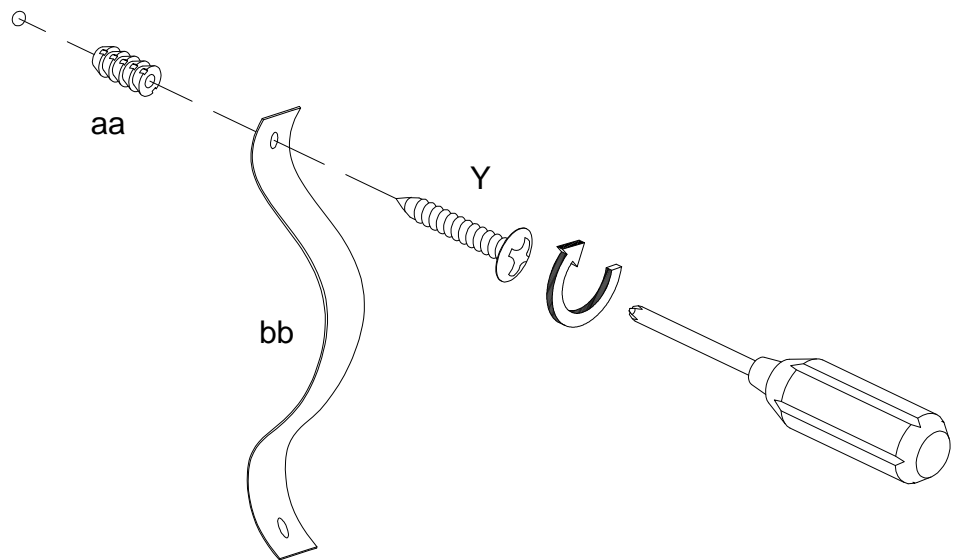

Using screw (Y) secure velcro strap (bb) into anchor (aa) to wall with Philips head screwdriver as per diagram.

Step 34

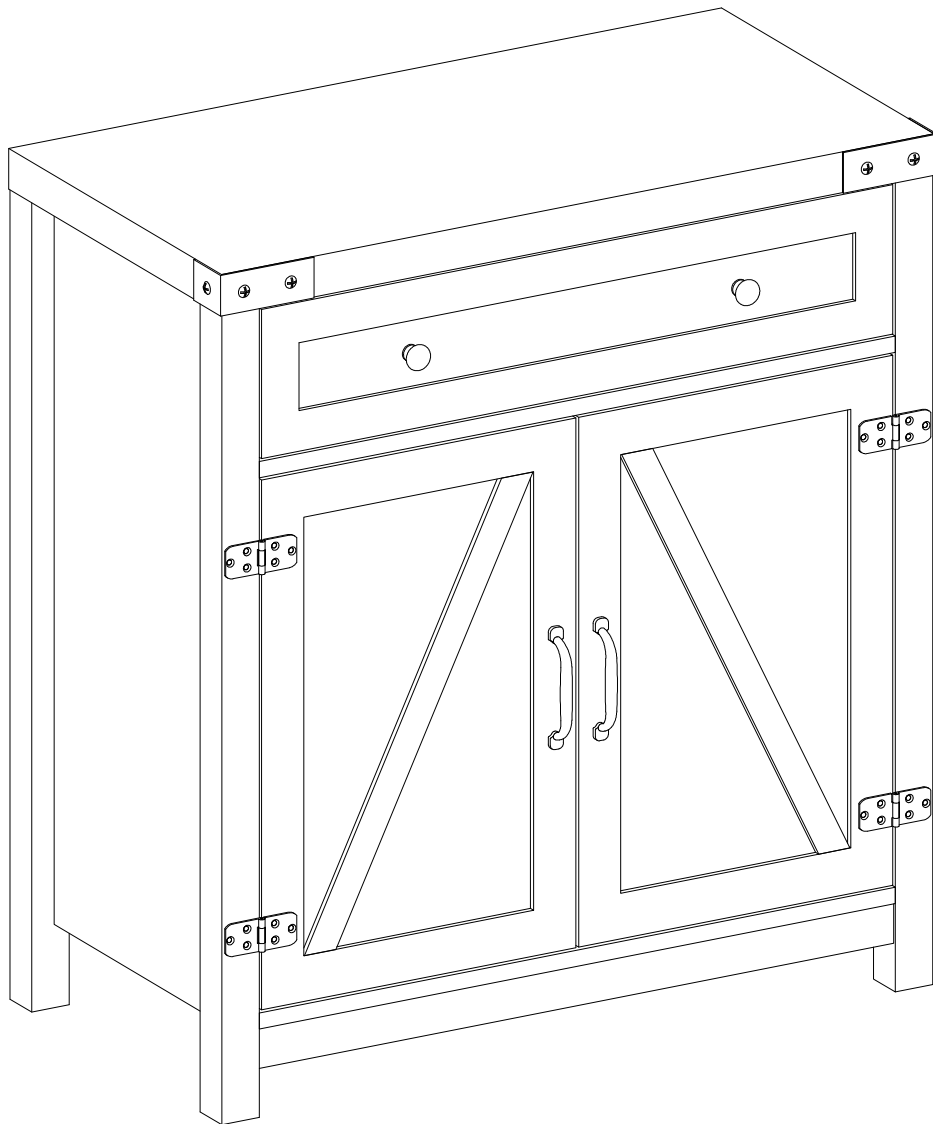

Final Assembly