

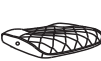

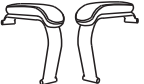

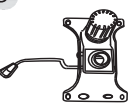





ZFFL-0801 ASSEMBLY INSTRUCTIONS

ZFFL-0801 Anleitung zur Montage

hello@furniliving.com

If you find any missing parts, please let us know, and we will send them to you as soon as possible.
 Wenn Sie fehlende Teile feststellen, lassen Sie es uns bitte wissen, und wir werden sie Ihnen so schnell wie mlich zusenden.

A 	B 	C 	D 	E  X5	F 	G 
H 	I M6x14mm  X10	J M6x20mm  X4	K M 6x30mm  X4	L M8x60mm  X4	M 	

1

Attention:
 When assembling, first insert all the screws until they are about 50% tight, then tighten all screws fully to 100%.
 Bei der Montage setzen Sie zuerst alle Schrauben ein und ziehen Sie sie bis etwa 50 % an, bevor Sie alle Schrauben vollständig auf 100 % anziehen.

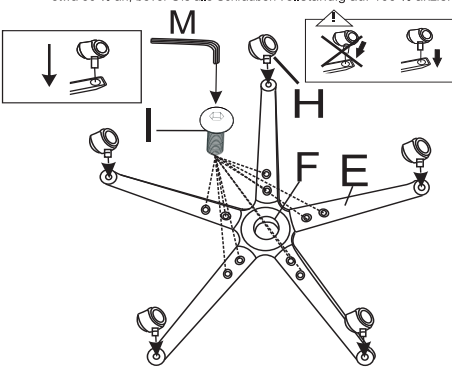

2

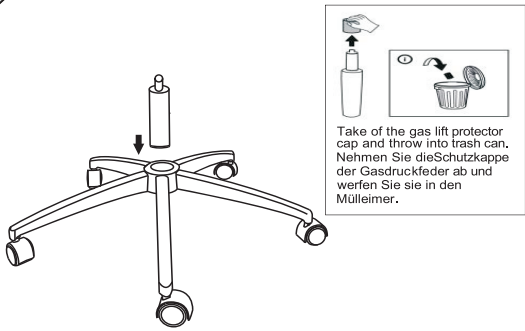

Take of the gas lift protector cap and throw into trash can.
 Nehmen Sie die Schutzkappe der Gasdruckfeder ab und werfen Sie sie in den Mülleimer.

3

Attention:
 When assembling, first insert all the screws until they are about 50% tight, then tighten all screws fully to 100%.
 Bei der Montage setzen Sie zuerst alle Schrauben ein und ziehen Sie sie bis etwa 50 % an, bevor Sie alle Schrauben vollständig auf 100 % anziehen.

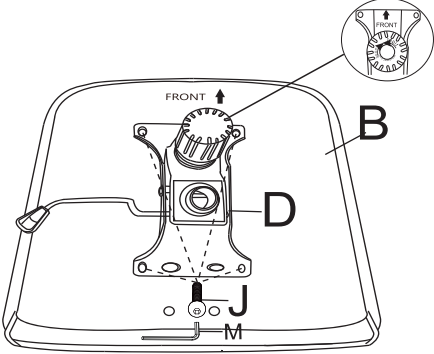

4

Attention:
 When assembling, first insert all the screws until they are about 50% tight, then tighten all screws fully to 100%.
 Bei der Montage setzen Sie zuerst alle Schrauben ein und ziehen Sie sie bis etwa 50 % an, bevor Sie alle Schrauben vollständig auf 100 % anziehen.

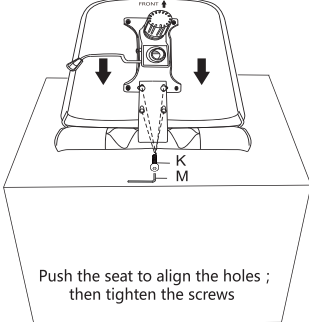

Push the seat to align the holes ;
 then tighten the screws

5



6

Attention:
 When assembling, first insert all the screws until they are about 50% tight, then tighten all screws fully to 100%.
 Bei der Montage setzen Sie zuerst alle Schrauben ein und ziehen Sie sie bis etwa 50 % an, bevor Sie alle Schrauben vollständig auf 100 % anziehen.

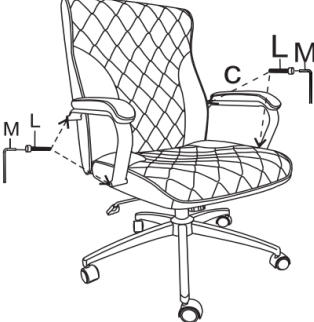

Function



1 Load capacity up to 300 lb
Tragfähigkeit bis zu 300 lb

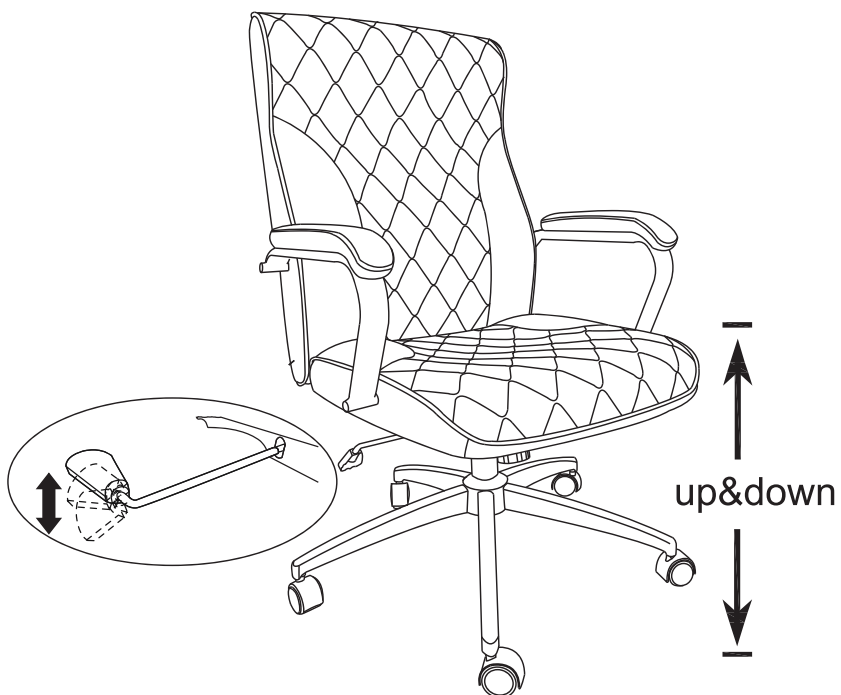

2 Seat Height adjustment (pull up on the control handle to adjust)
Sitzhöhenverstellung (Bedienhebel zum Einstellen nach oben ziehen)



3 360 degree swivel
360-Grad-Schwenk

