

ASSEMBLY INSTRUCTIONS

TOOLS REQUIRED

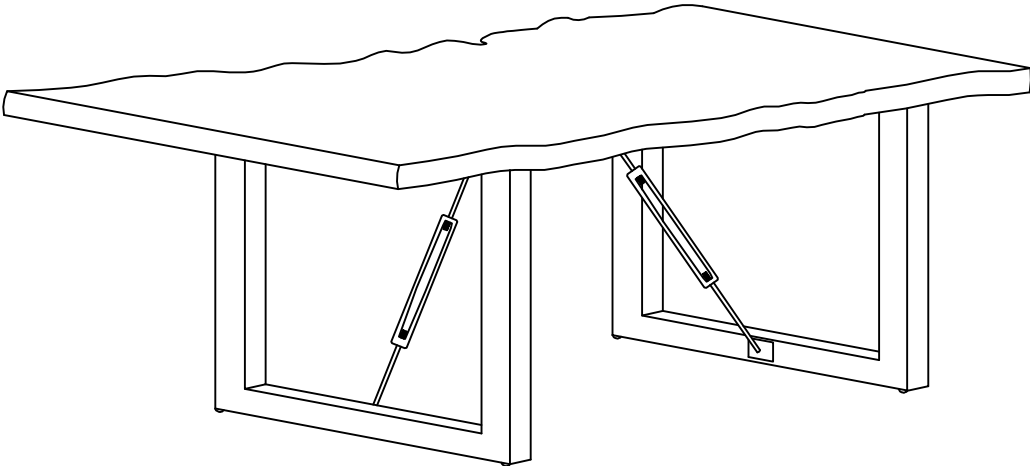

Allen Wrench
(Included)



2 - Persons
Recommended

ASSEMBLY RATING



EASY —————> DIFFICULT

The Assembly Rating is a 5-point system showing the level of effort needed to assemble a specific product.

Thank you for your purchase!

We hope you enjoy this new addition to your home for many years to come. Our commitment to providing quality products does not simply end when you purchase our product. We fully stand behind our products from start to finish.



CHECK BEFORE STARTING

Are you missing anything?

Double-check all parts, hardware and accessories listed on Page 6 are accounted for.

Check out our Quick Tips!

We recommend reviewing the pre-assembly handouts. Even experts need a refresher now and then!

Prep Time!

Please review the assembly instructions and all diagrams prior to assembling. Arrange parts as recommended on Page 7 and group identical hardware together to make assembling easier.

PRE ASSEMBLY INTRODUCTION

We understand building ready-to-assemble furniture can be a challenging experience for some. To help avoid confusion, we have provided some helpful tips that may speed up the process.

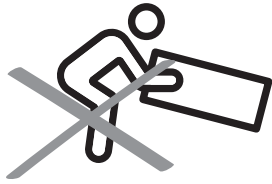

Teamwork

ALWAYS have at least two people to help with transporting and assembling the product to avoid potential injury and/or damage.

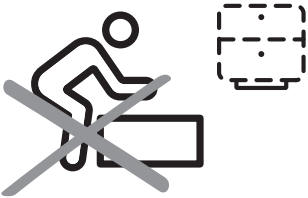

Suitable Location

Assembling near the area of the intended location is highly recommended.



Sufficient Space

Make sure you have enough space to move around during the assembly.



Avoid Scratches

Use cardboard, blankets or a carpeted area while assembling furniture to prevent scratches.



Flat Surface

Make sure the furniture rests on a flat and level surface with each leg evenly touching the floor.

ASSEMBLY AND CARE ADVICE



FAILURE TO FOLLOW THE GUIDELINES BELOW MAY RESULT IN INJURY AND/OR PROPERTY DAMAGE.



Position each part correctly and insert screws or bolts into their respective holes.



Turn clockwise to tighten and only tighten when step is completed or when instructed to do so.



Use the appropriate hand tools or power tools for assembly. Select steps, such as tightening screws and/or bolts, may require hand tools to avoid causing damage during assembly.



Save the instructions and store any supplied tools for later maintenance.

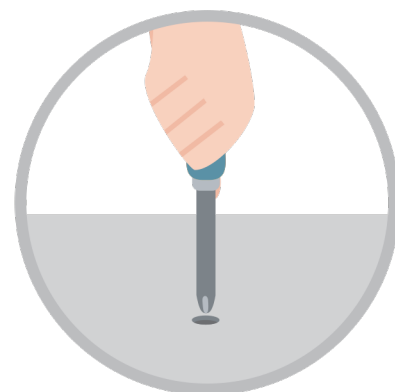

After two weeks, check and tighten any loose hardware and repeat again every six months thereafter.

IT IS THE USER'S RESPONSIBILITY TO MAINTAIN THE FURNITURE. THE HARDWARE MAY LOOSEN OVER TIME AND MAY CAUSE THE FURNITURE TO BE WOBBLY AND UNABLE TO SUPPORT ITS INTENDED WEIGHT CAPACITY. THIS MAY LEAD TO COLLAPSE AND MAY CAUSE SERIOUS INJURY.

TABLE

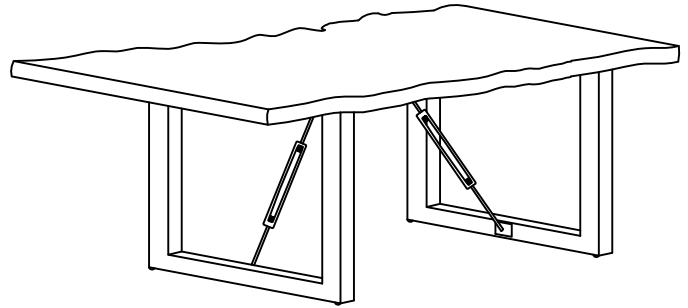
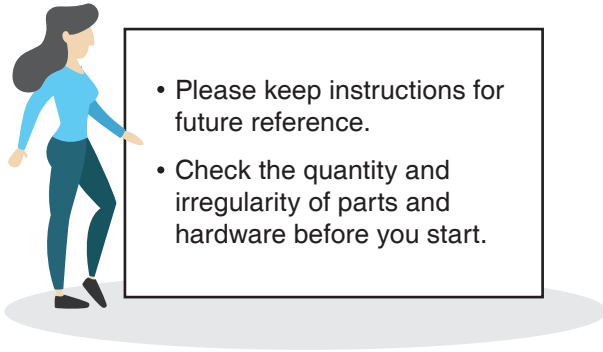

PARTS

#1 1pc



Table Top

#2 2pcs

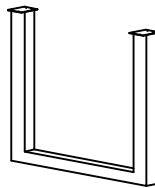
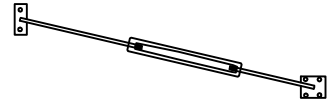

Table Leg

#3 2pcs



Diagonal Support

HARDWARE

#A 28pcs

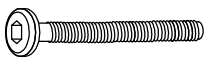

25mm JCBC BOLT

#B 28pcs



M6 Lock Washer

#C 1pc



Allen Wrench

#D 4pcs



Adjuster

ASSEMBLY INSTRUCTIONS

1

Part #1 x 1pc

Part #2 x 2pcs

Hardware #A x 16pcs

Hardware #B x 16pcs

1. Prepare 16 bolts assembly by first inserting a spring washer (#B) onto the bolt (#A).
2. Align the table legs (#2) to the holes along the bottom of the table top (#1), then insert the bolt assemblies into each hole from within and secure.

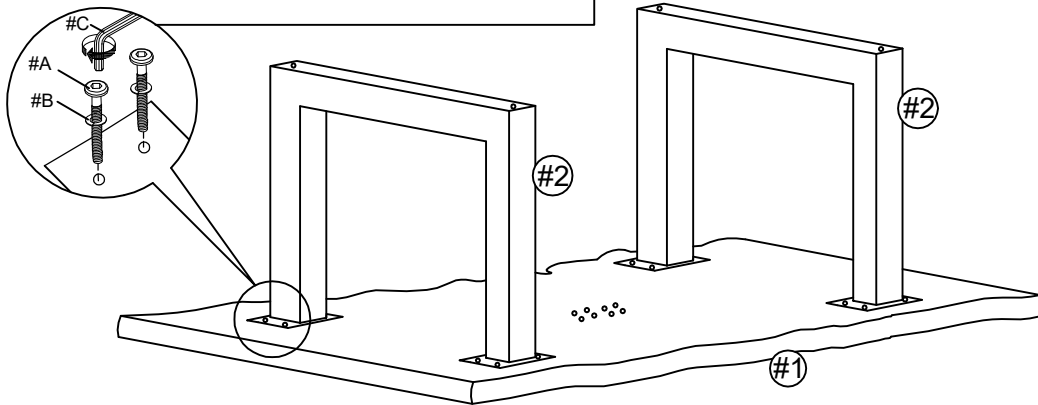

2

Part #3 x 2pcs

Hardware #A x 12pcs

Hardware #B x 12pcs

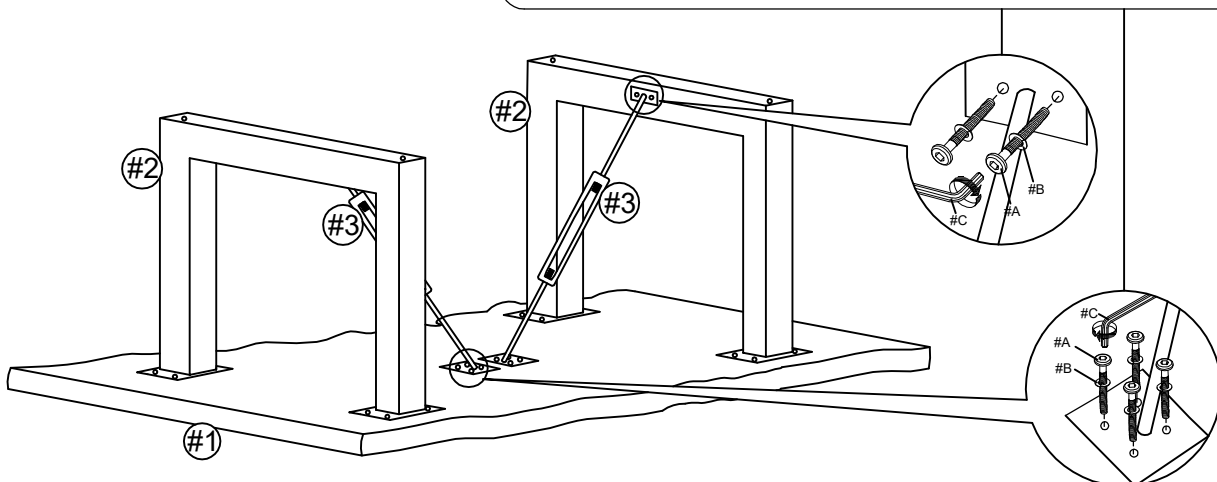

1. Prepare 12 bolts assembly by first inserting a spring washer (#B) onto the bolt (#A) then a flat washer (#C) onto that same bolt (#A).
2. Align the diagonal support (#3) to the holes on the bottom of table top (#1) and table leg (#2), then insert the bolt assemblies into each hole from within and secure.



ASSEMBLY INSTRUCTIONS

3

Hardware  x 4pcs

Install adjuster () to the hole at the bottom of table leg ()

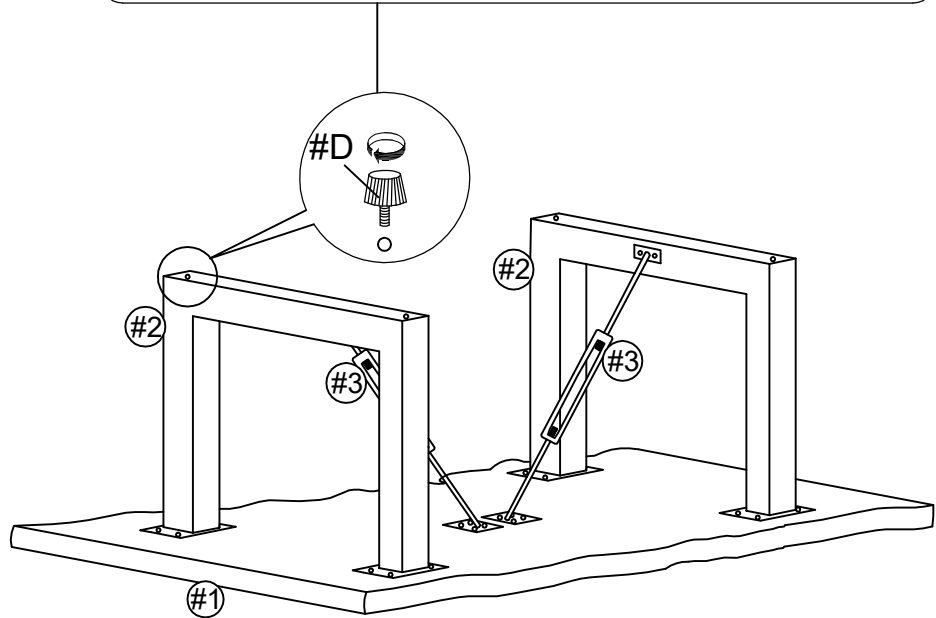

4

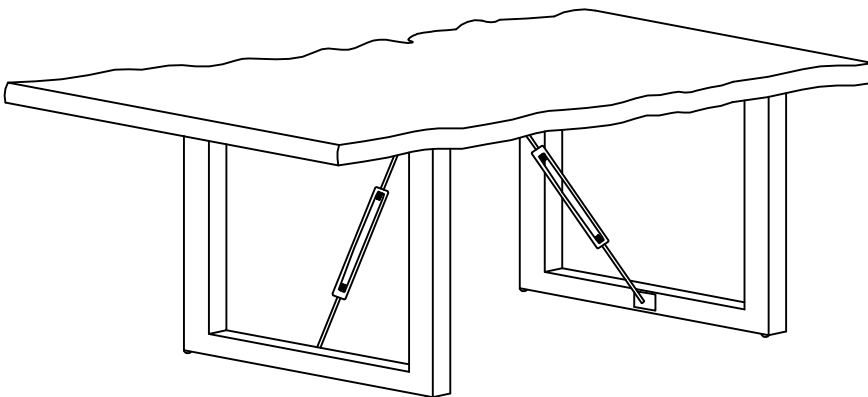

ASSEMBLY COMPLETED



Please ensure the furniture rests on an even and flat surface. If the product wobbles or feels loose, double-check all bolts and/or screws are properly tightened and secured.



Keep this handy!

Please retain this instruction manual and any order-related information for future reference.