

# INSTRUCTION MANUAL

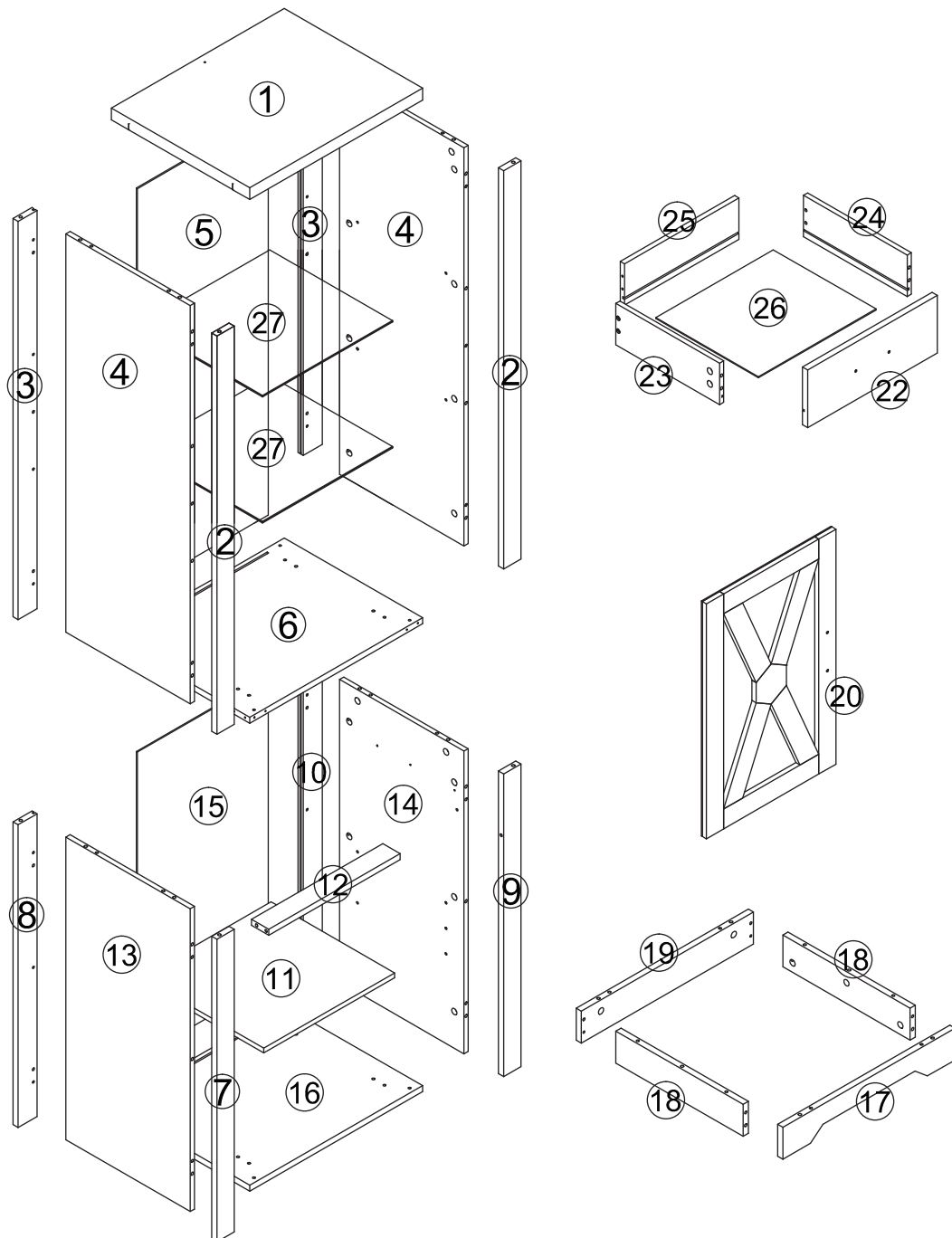

# ASSEMBLY INSTRUCTIONS

Carefully unpack all the components and verify that all the necessary parts are included as listed in the packaging.











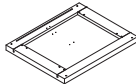

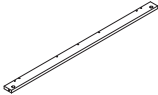
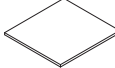
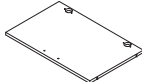
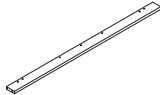
Identify each component and refer to the provided assembly diagram or step-by-step instructions.

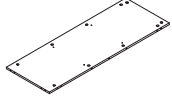
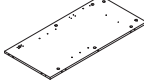
Assemble the furniture in the order specified to ensure proper alignment and fit.

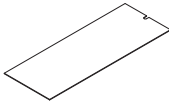
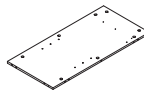
Use the provided tools or recommended tools for assembly. Do not use excessive force when tightening screws or bolts.

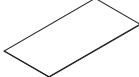
If any difficulties arise during assembly, consult the troubleshooting section or contact our customer support.

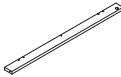
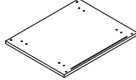
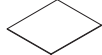
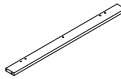
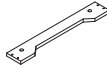
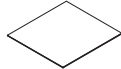
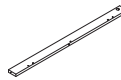
## BOARD PARTS LIST

NO.	PICTURE	QTY	NO.	PICTURE	QTY	NO.	PICTURE	QTY
①	 Top Panel	1	⑩	 Lower Right Side Back Vertical Strip	1	⑲	 Back Kickboard	1
②	 Upper Left / Right Side Front Vertical Strip	2	⑪	 Movable laminate	1	⑳	 door panel	1
③	 Upper Left / Right Side Back Vertical Strip	2	⑫	 Drawer Pull Strip	1	㉒	 Drawer Front Panel	1
④	 Upper Side Left / Right Panel	2	⑬	 Lower Left Side Panel	1	㉓	 Drawer Left Side Panel	1
⑤	 Upper Back Panel	1	⑭	 Lower Right Side Panel	1	㉔	 Drawer Right Side Panel	1
⑥	 Middle Shelf	1	⑮	 Lower Back Panel	1	㉕	 Drawer Back Panel	1
⑦	 Lower Left Side Front Vertical Strip	1	⑯	 Bottom Panel	1	㉖	 Drawer Bottom Panel	1
⑧	 Lower Left Side Back Vertical Strip	1	⑰	 Front Kickboard	1	㉗	 tempered glass	2
⑨	 Lower Right Side Front Vertical Strip	1	⑱	 Side Kickboard	2			

# ASSEMBLY INSTRUCTIONS

Carefully unpack all the components and verify that all the necessary parts are included as listed in the packaging.













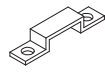

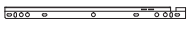





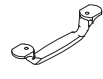





Identify each component and refer to the provided assembly diagram or step-by-step instructions.

Assemble the furniture in the order specified to ensure proper alignment and fit.

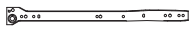
Use the provided tools or recommended tools for assembly. Do not use excessive force when tightening screws or bolts.

If any difficulties arise during assembly, consult the troubleshooting section or contact our customer support.

## HARDWARE PARTS LIST

NO.	PICTURE	QTY	NO.	PICTURE	QTY	NO.	PICTURE	QTY
A	 2 in 1 Screw	56+2	CR	 Silent Cabinet Slide	1	S	 Buckle	2
B	 Eccentric Wheel	64+2	DR	 Silent Drawer Slide	1	T	 Countersunk Self-Tapping Screw (3*14mm)	6
C	 Wooden Tenon	50+2	L	 Double-Ended Screw	4	U	 Expansion Tube	1
D	 Countersunk Self-Tapping Screw (5*40mm)	16+2	M	 Aluminum Alloy Handle	2	V	 L-Shaped Anti-Tipping Iron Piece	1
E	 Countersunk Self-Tapping Screw (3,5*10mm)	22+2	N	 Handle Screw	4	W	 Large Flat Head Self-Tapping Screw(4*32mm)	1
F	 Large Flat Head Self-Tapping Screw (4*12mm)	17+2	O	 Back Panel Fastener	12+2	Y	 Anti-Collision Iron Plate	4
G1	 Glass Shelf Bracket	8	P	 Screw Hole Cover	40+4	Z	 Large Bend Soft-Close Hinge	2
CL	 Silent Cabinet Slide	1	Q	 Round LED Strip	1	G2	 Lower Shelf Bracket	4
DL	 Silent Drawer Slide	1	R	 USB connection adapter	1	E1	 Countersunk Self-Tapping Screw (3,5*12mm)	12+2

STEP 1

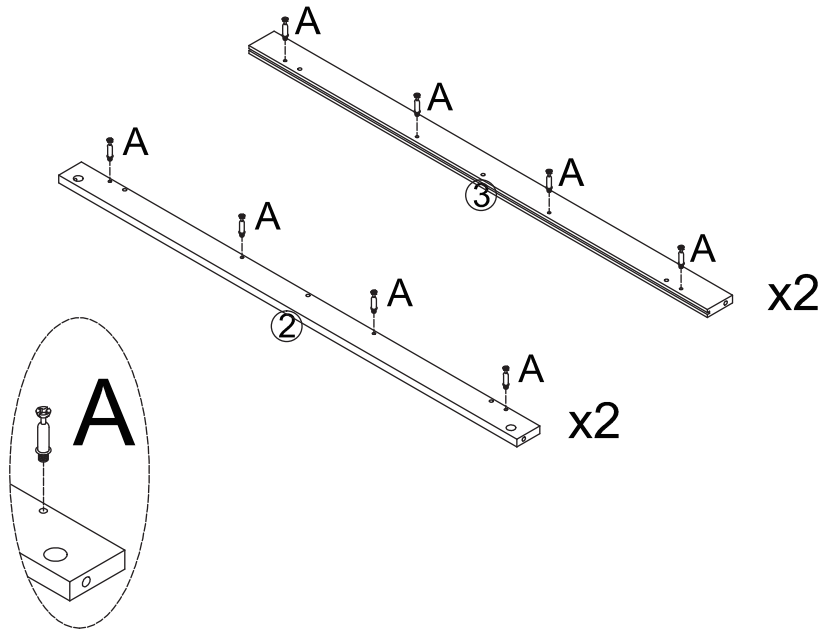
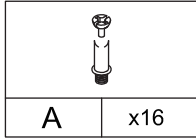

STEP 2

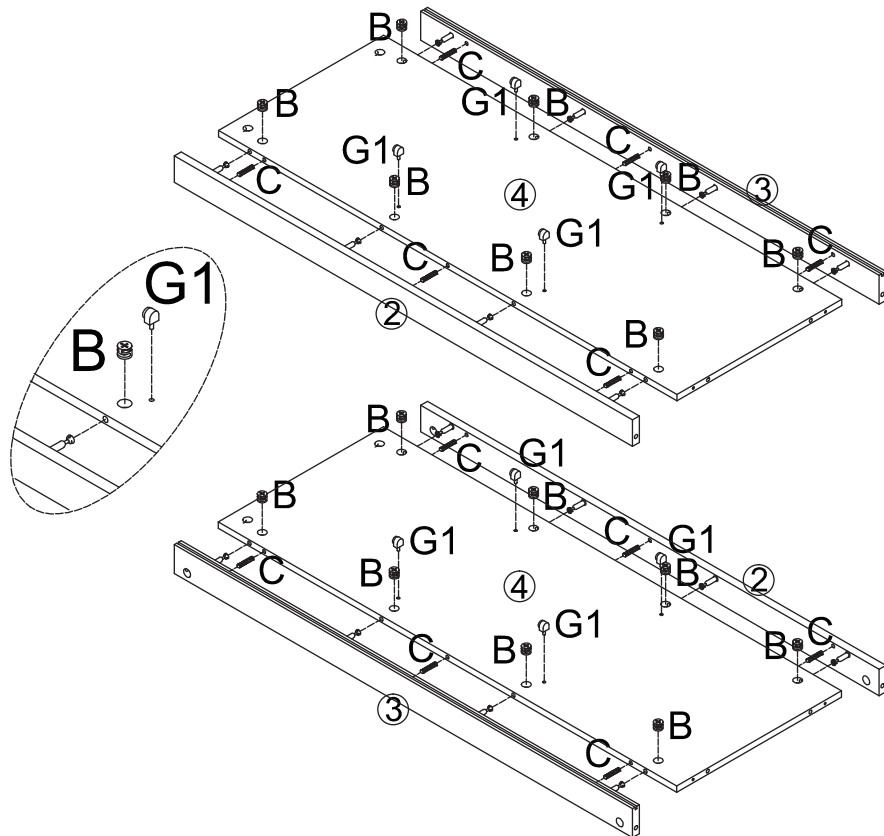
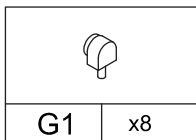
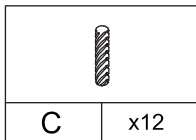
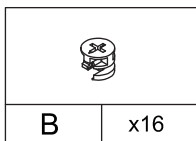

STEP 3

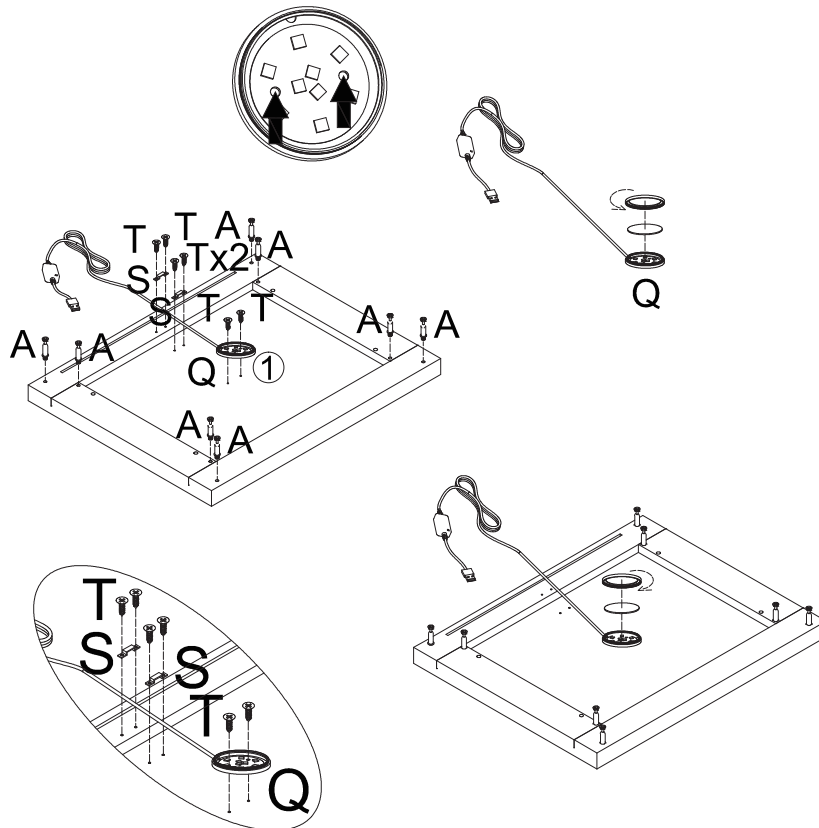
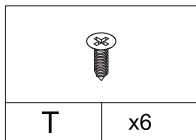
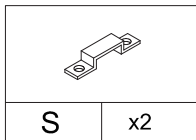
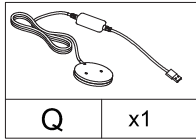
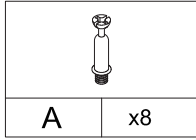

STEP 4

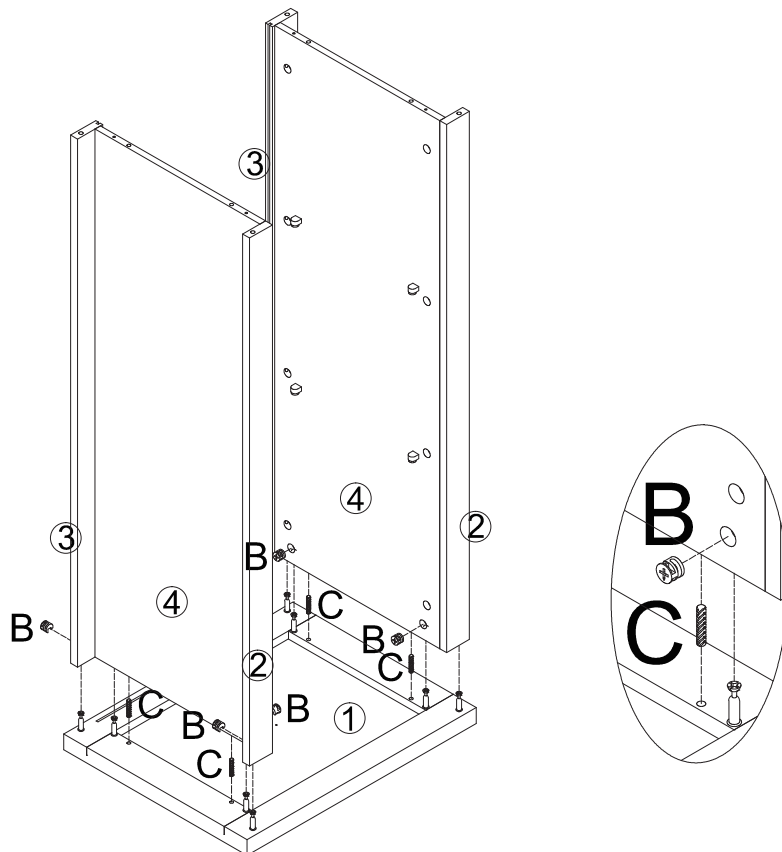
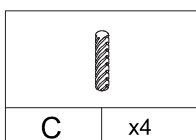
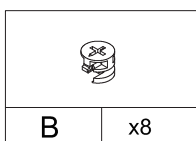

STEP 5

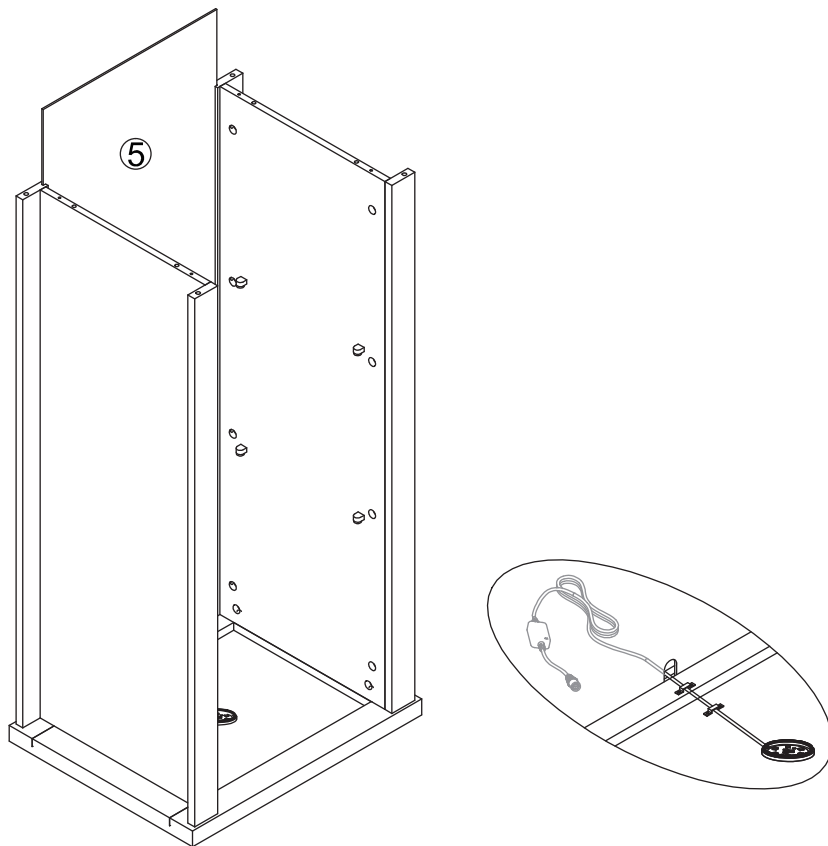

STEP 6

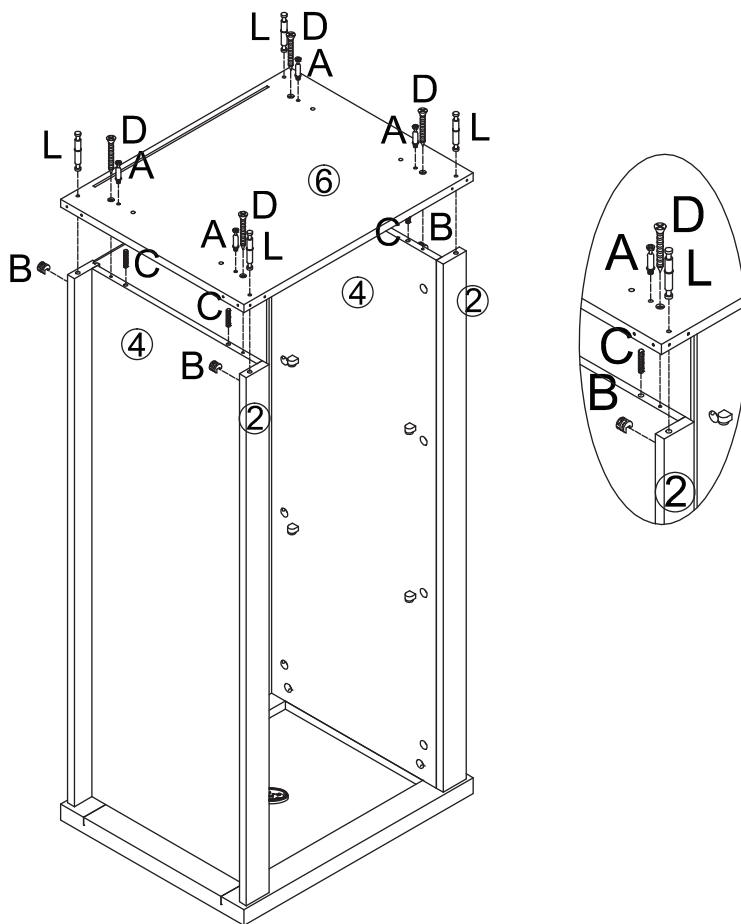
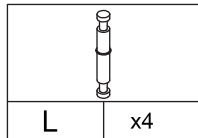
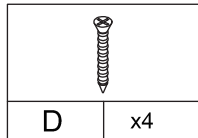
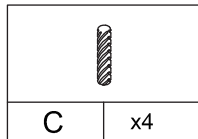
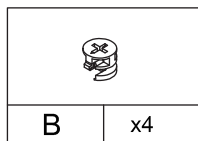
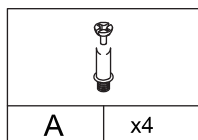

STEP 7

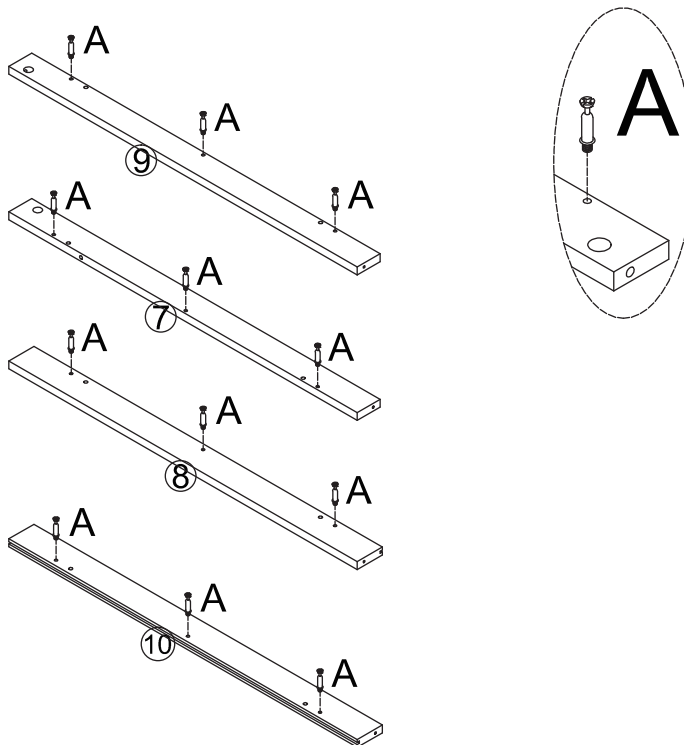
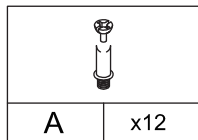

STEP 8

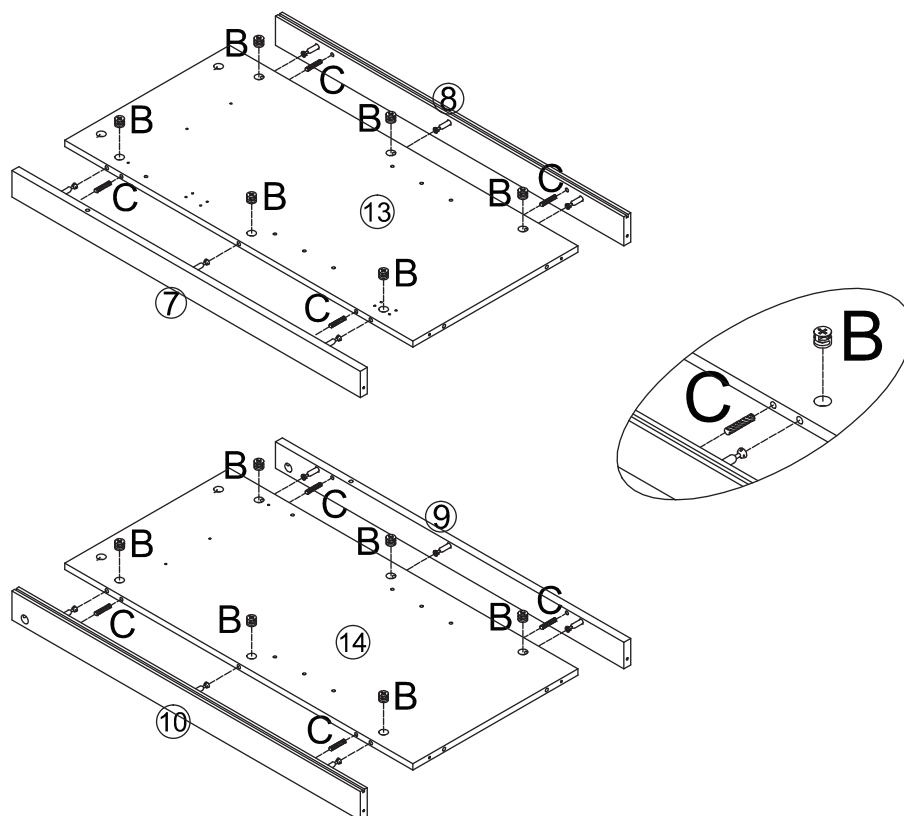
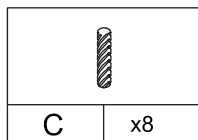
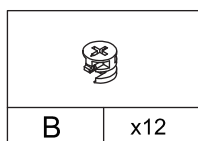

**STEP 9**

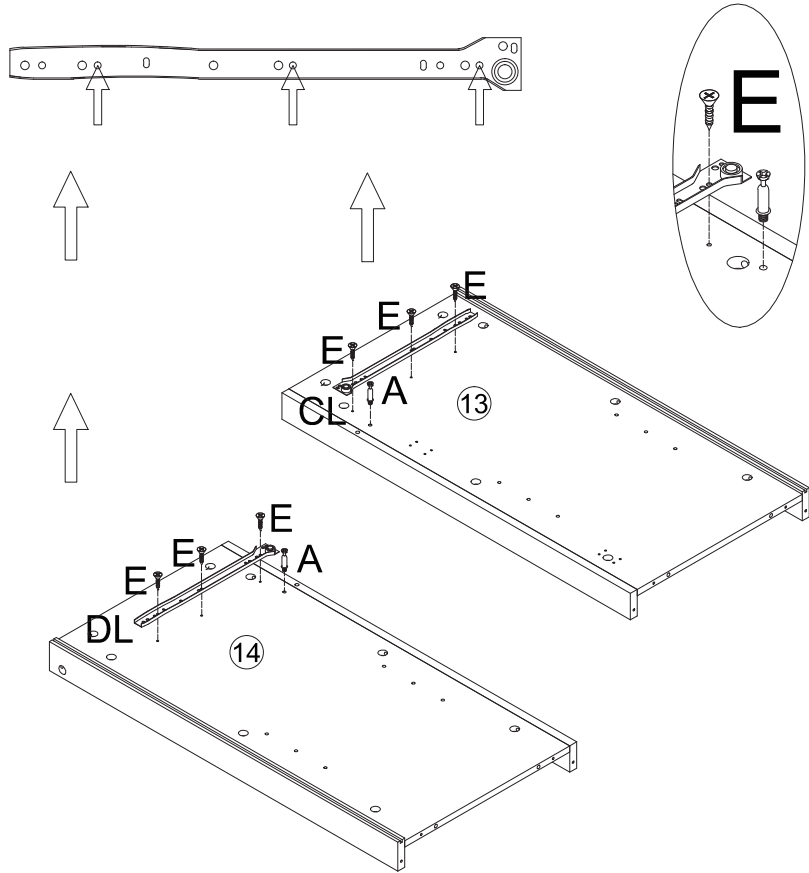
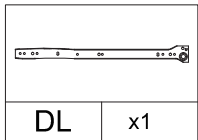
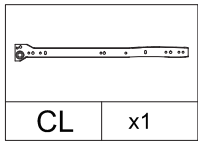
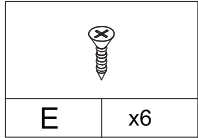
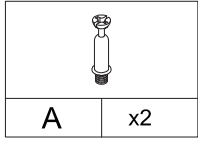

**STEP 10**

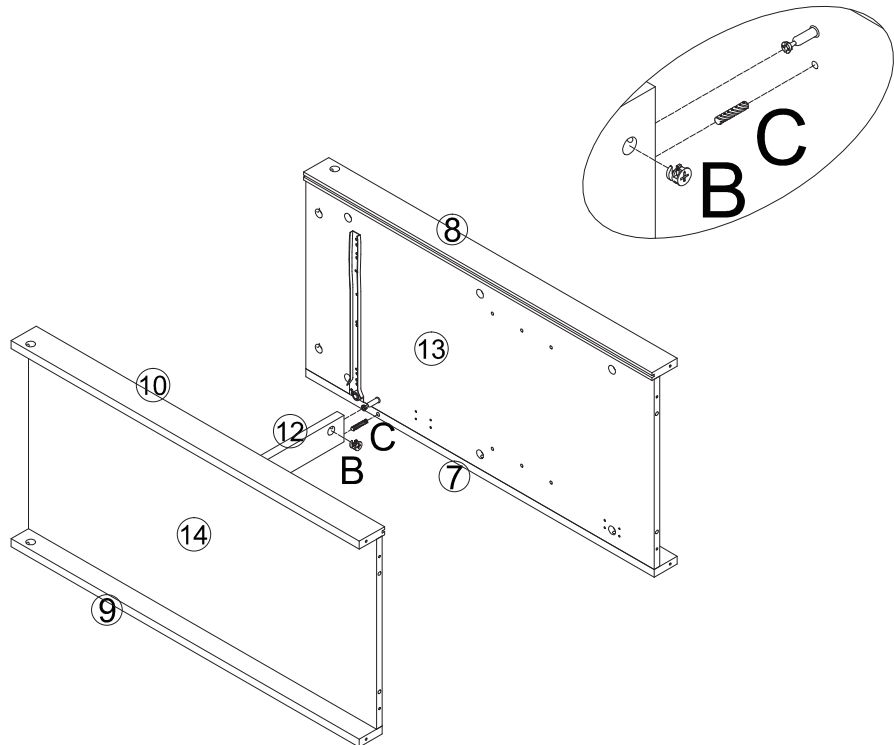
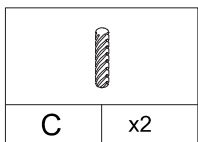
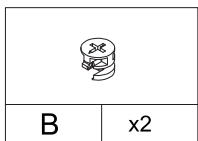

**STEP 11**

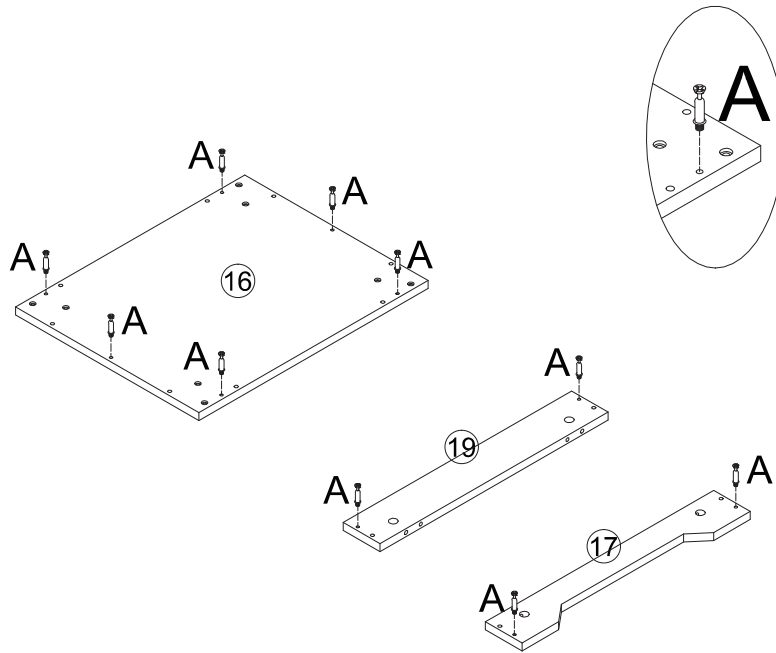
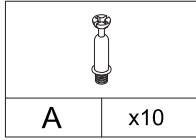

**STEP 12**

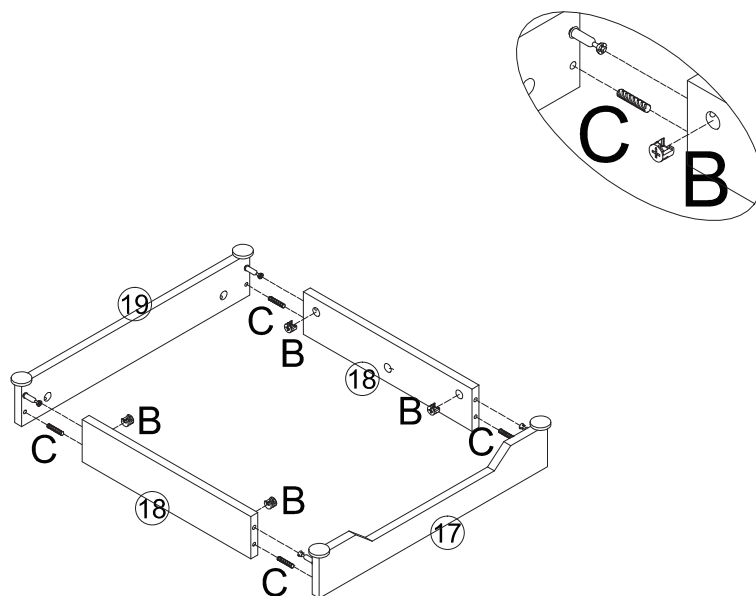
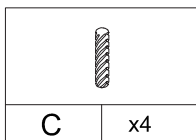
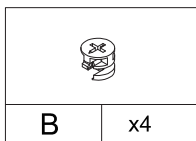

STEP 13

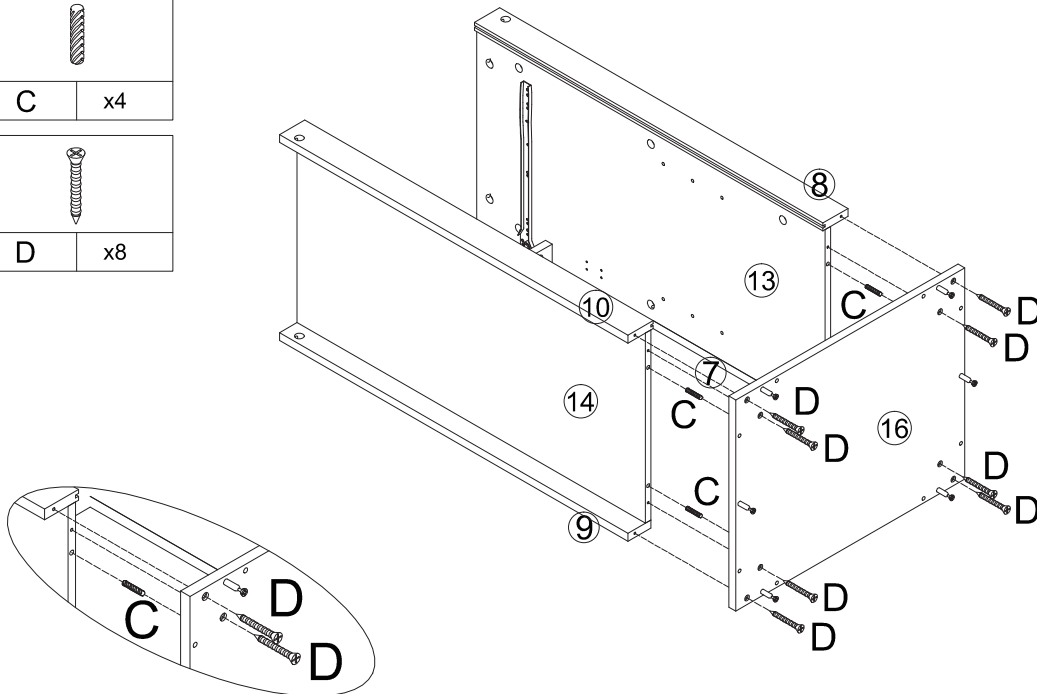
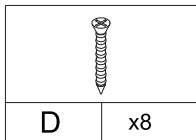
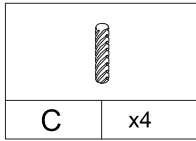

STEP 14

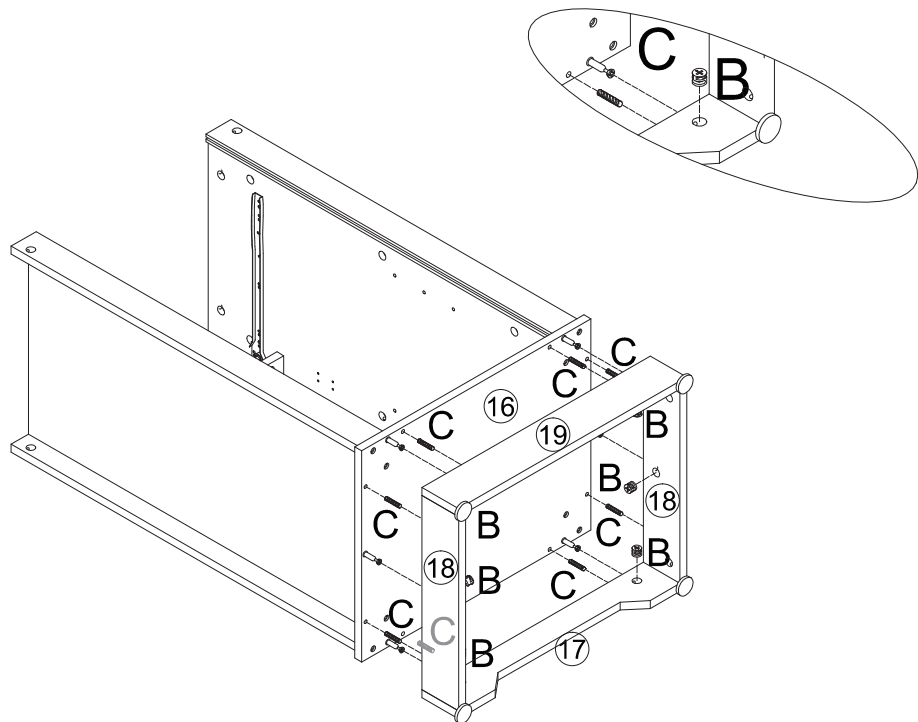
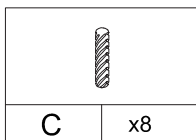
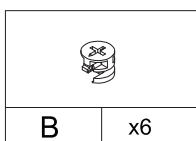

STEP 15

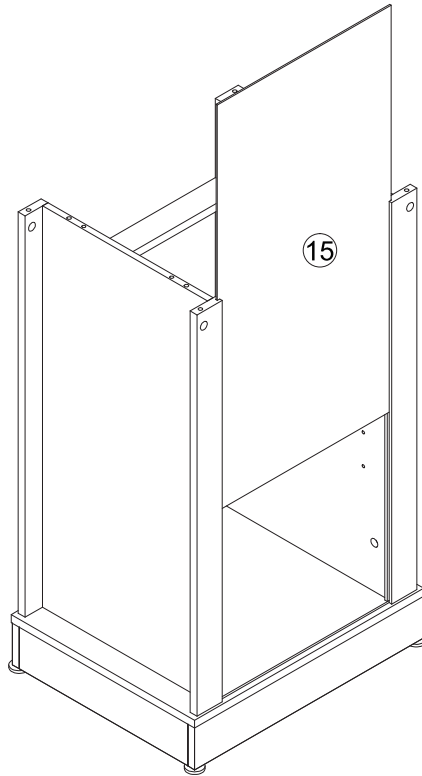

STEP 16

	
B	x8

	
C	x4

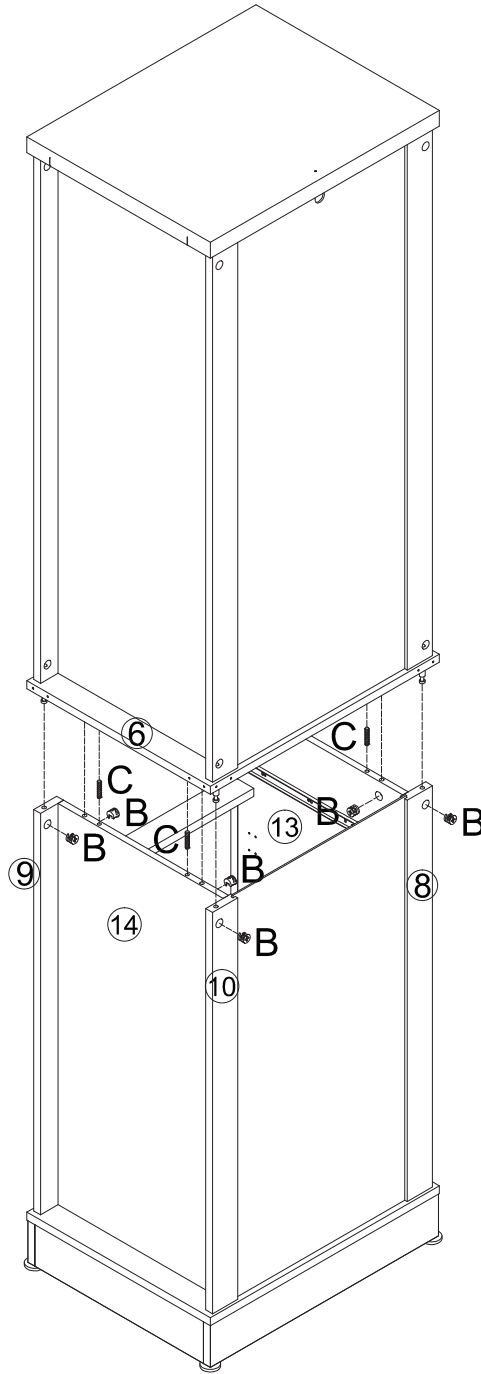
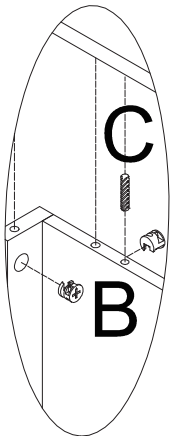

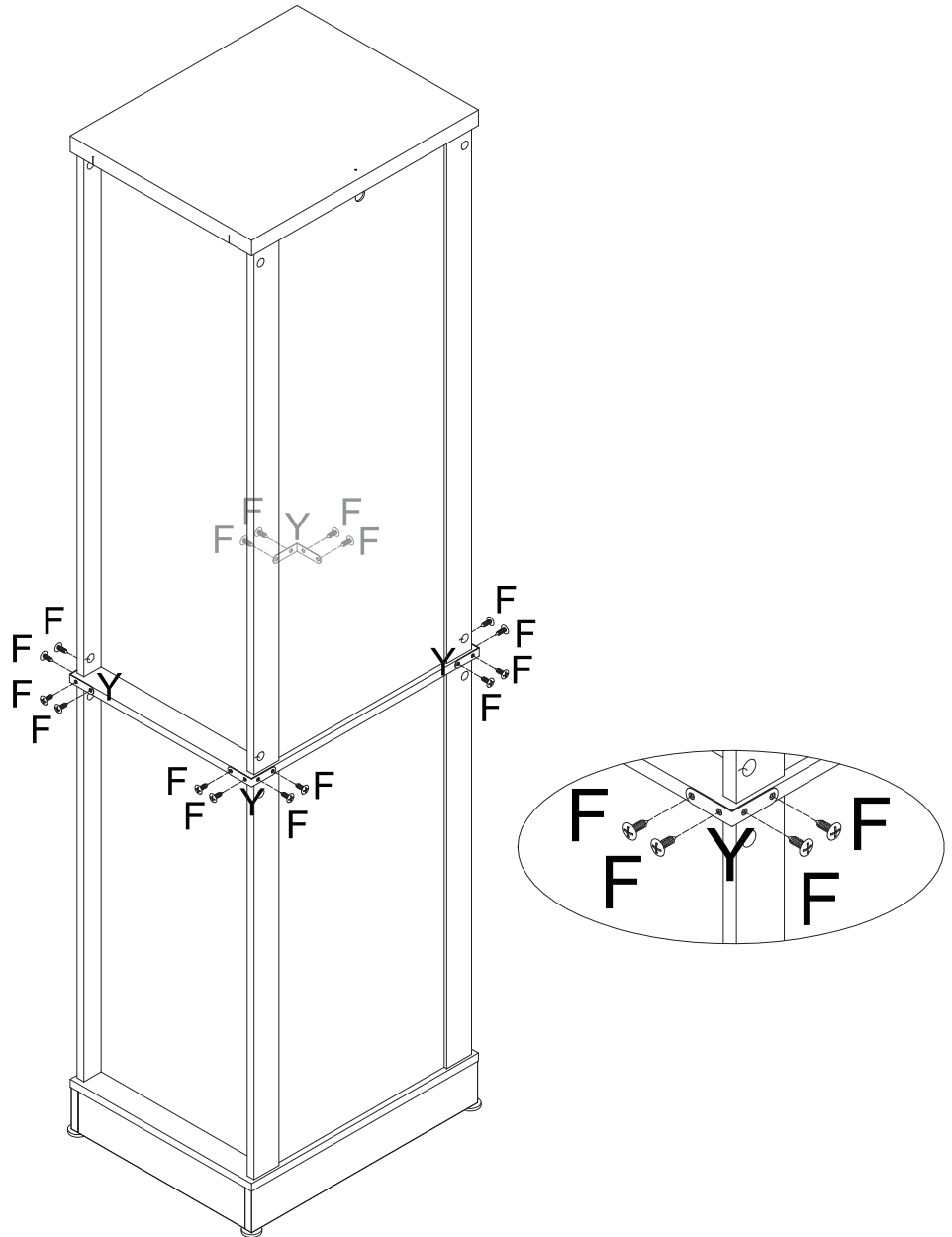

STEP 17

	
F	x16



STEP 18

	
E1	x12

	
O	x12

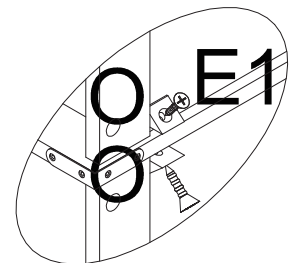
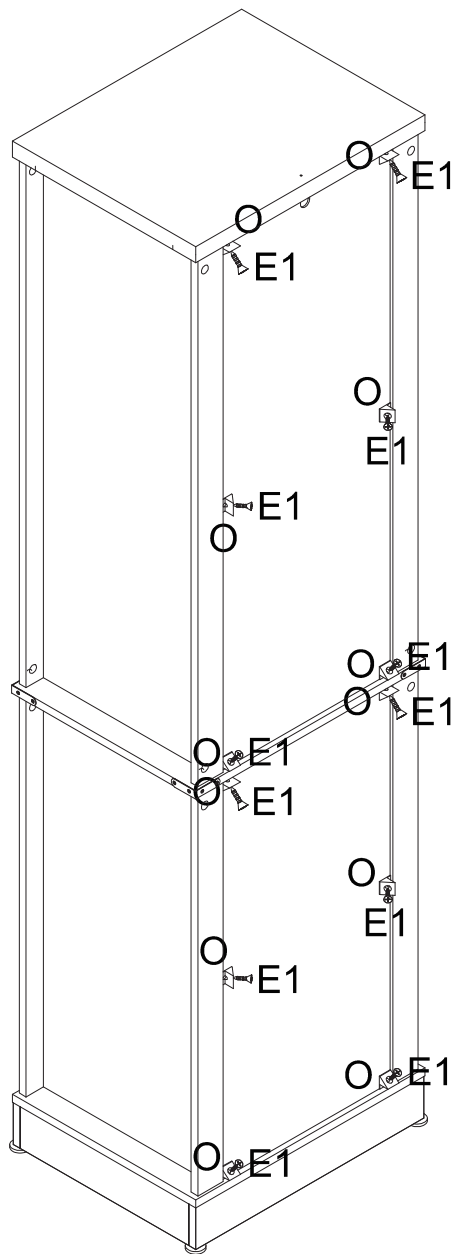

STEP 19

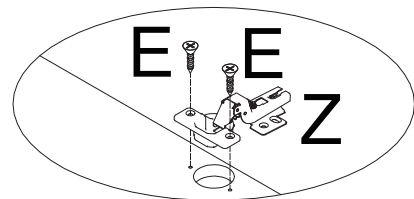
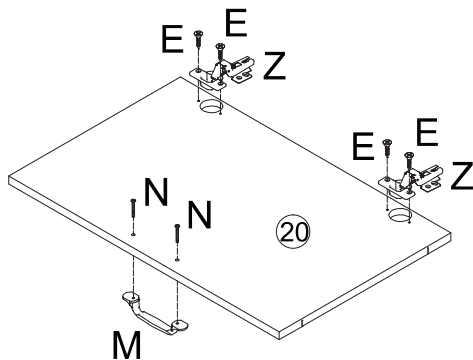
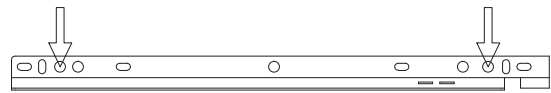
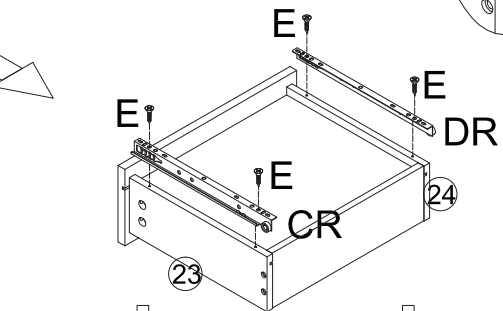
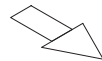
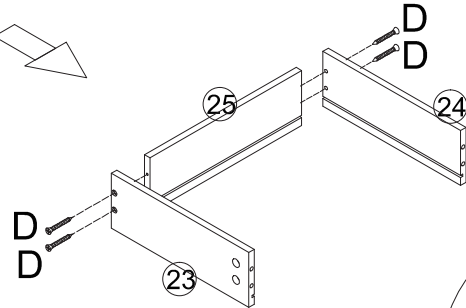
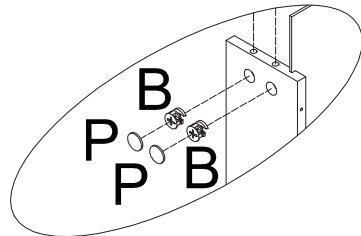
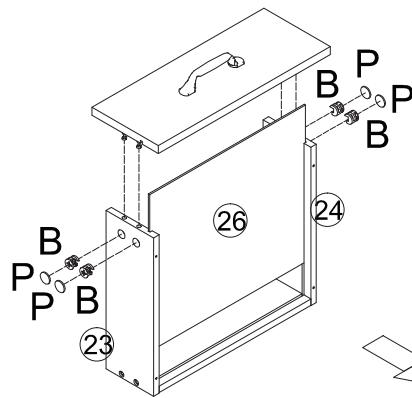
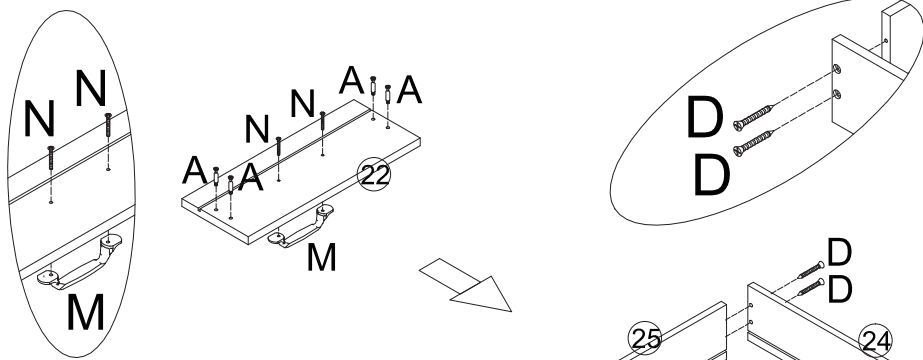
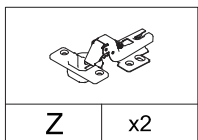
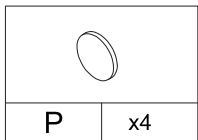
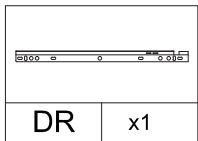
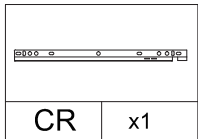
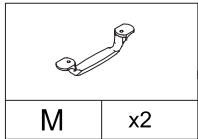
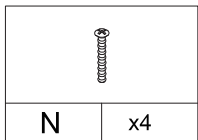
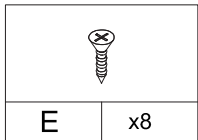
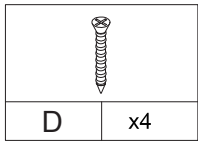
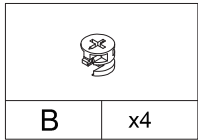
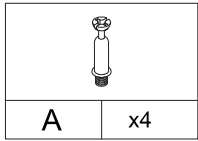

### STEP 20

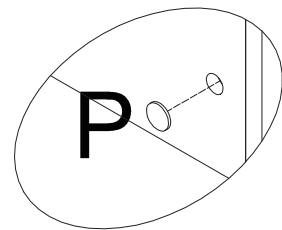
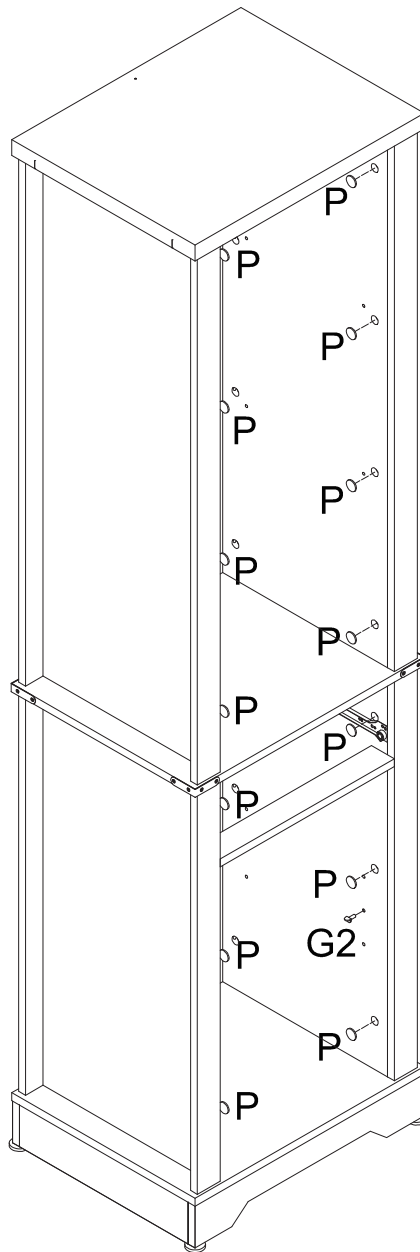
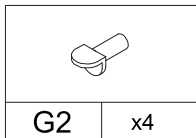
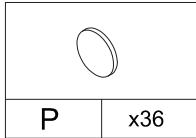

## STEP 21

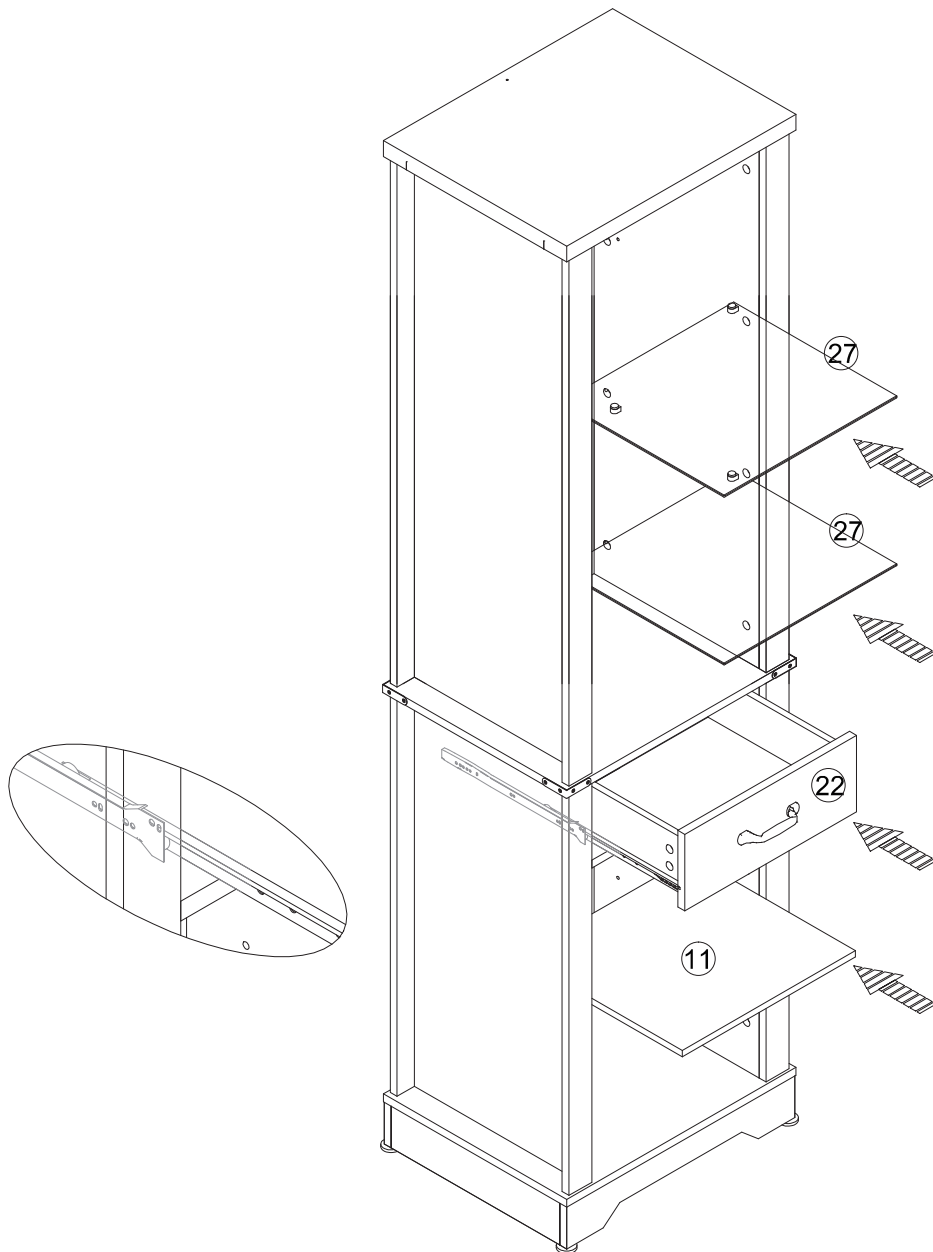

STEP 22

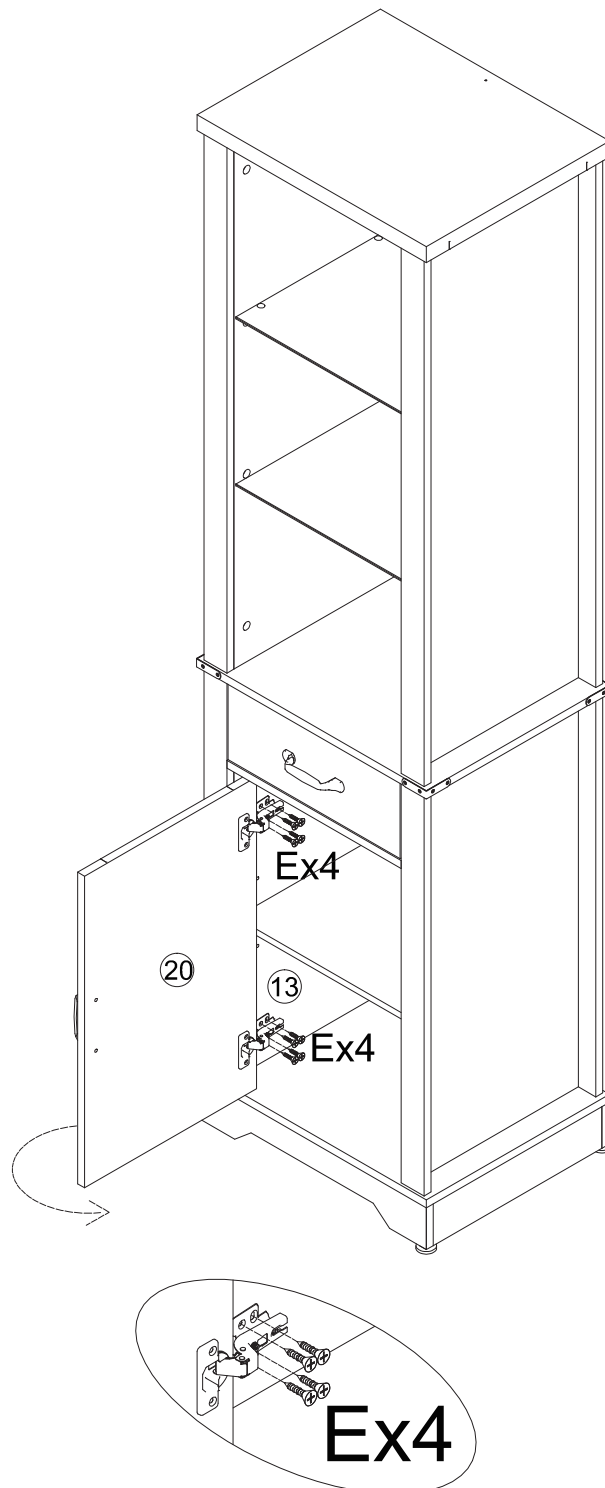
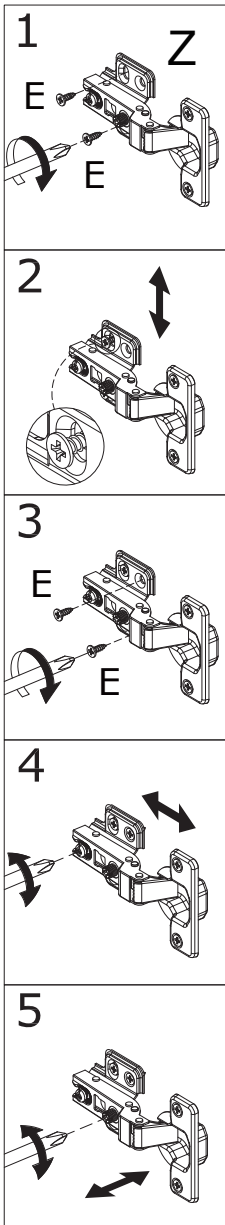
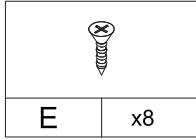

### STEP 23

	
R	x1

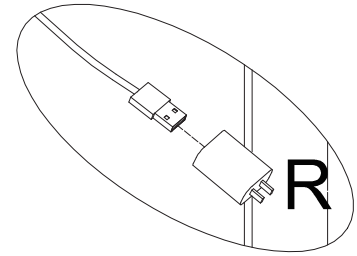
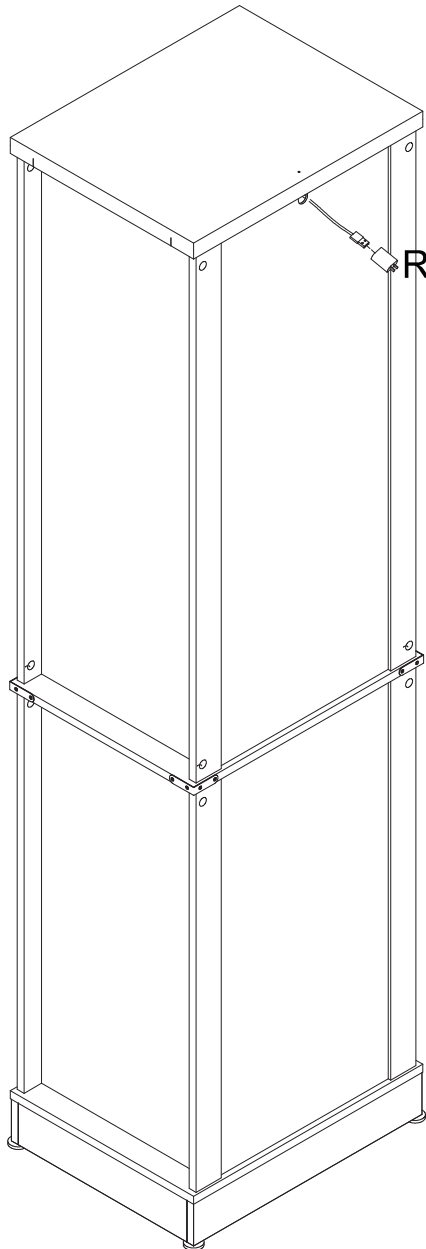

### STEP 24

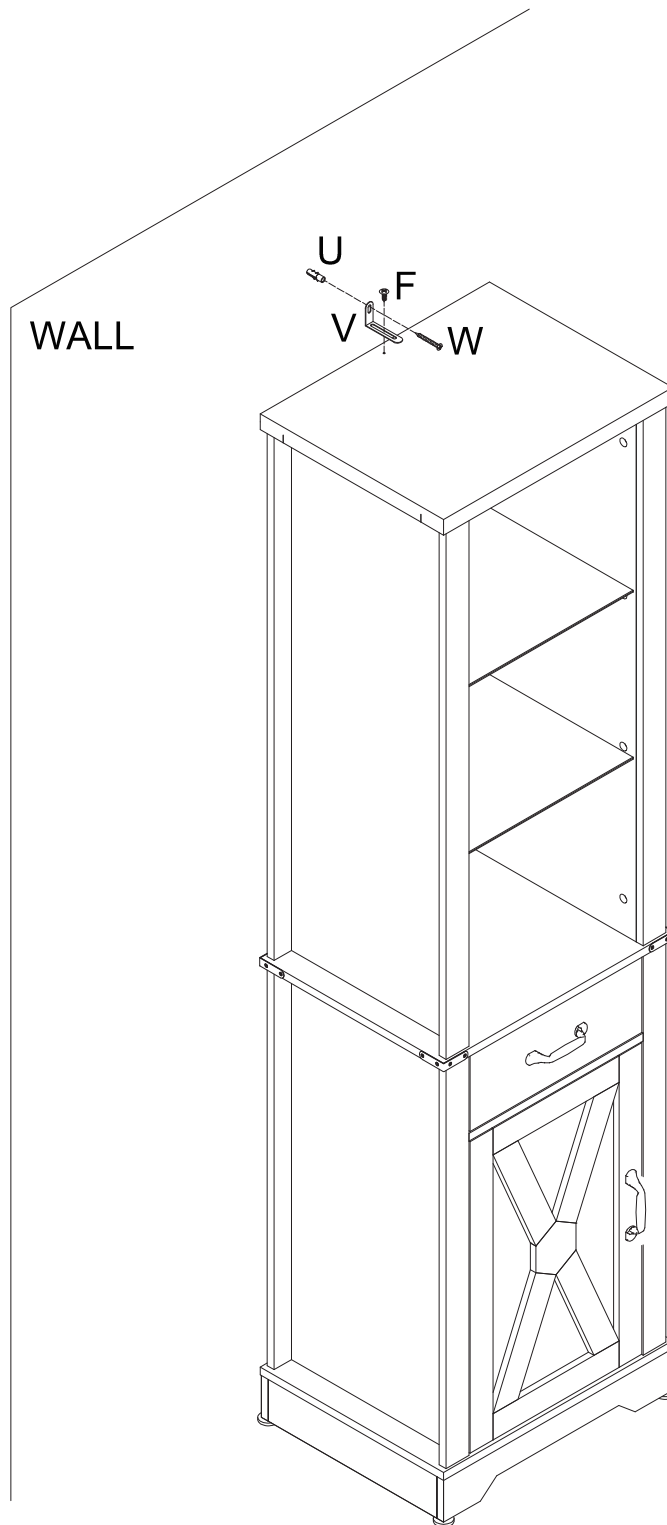
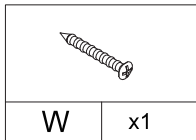
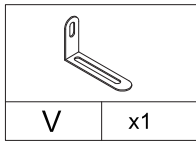
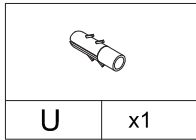
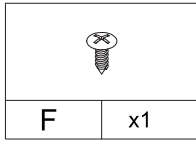

## MAINTENANCE AND CARE

Clean regularly using a soft brush or vacuum with a brush attachment. Avoid harsh chemicals or abrasive cleaners.

Wash with a hose or pressure washer on a low-pressure setting for heavy soiling. Rinse thoroughly afterward.

Ensure proper drying after cleaning or exposure to rain to prevent mold or mildew growth.

Protect from extreme weather by moving furniture to a covered area or using furniture covers or tarps.

Avoid dragging or placing heavy objects on the furniture to prevent damage.

Apply UV protection spray or furniture wax to prevent fading and damage from the sun.

Regularly inspect for wear, loose strands, or damage and address issues promptly.

## WARRANTY INFORMATION

**Warranty Coverage:** Our warranty provides protection against manufacturing defects in materials and workmanship for a specified period from the date of purchase, as outlined in the accompanying warranty documentation.

**Exclusions:** The warranty does not cover damages resulting from misuse, negligence, accidents, normal wear and tear, unauthorized repairs or modifications, improper assembly, or failure to adhere to the care and maintenance guidelines provided.

### Warranty Claim Process

To initiate a return on Amazon, please follow these steps:

- 1 Log into your account and go to the "Your Orders" section.
- 2 Locate the order containing the item you wish to return.
- 3 Contact our customer service for assistance in obtaining a prepaid return label.
- 4 Once you receive the return label, securely affix it to the package.
- 5 You can then choose to drop off the package at a designated carrier location or arrange for a pickup.
- 6 After we receive and inspect the returned product, we will initiate the refund process.
- 7 The refund will be credited back to the original payment method used during the purchase.
- 8 Typically, refunds are processed within 3-5 business days.