

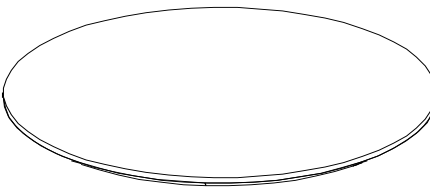

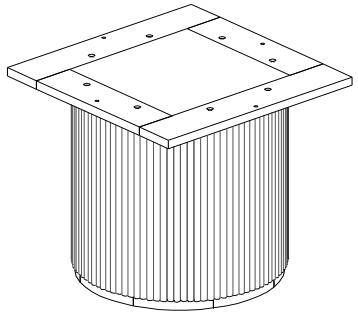

ASSEMBLY INSTRUCTIONS

SKU# 51031721

PARTS LIST

A	TABLE TOP X 1		<p>Before beginning</p> <ol style="list-style-type: none"> 1 - Carefully unpack and position the item on a clean, non-marring surface to assemble. 2 - Read this Assembly Instructions from beginning to end before starting to assemble. 3 - Take an inventory of the required parts to ensure all are available. 4 - To prevent accidental choking hazards, keep all packing materials away from small children. 5 - Only tighten hardware until ALL hardware are fully engaged on their locations. Overtighten bolts will damage the bolt threads. 6 - Use only factory provided hardware to assemble. Unapproved hardware can damage product or jeopardize the structural integrity of the product. 7 - The use of power tool to assemble is not recommended due to high risk of over-torque, which can damage the product. 			
B	LEG X 1					

Z	HARDWARE	<p>Z1</p>  <p>8X60MM X 4</p>	<p>Z2</p>  <p>8X19X2MM X 4</p>	<p>Z3</p>  <p>8X12X2MM X 4</p>	<p>Z4</p>  <p>4X59MM X 1</p>				
---	----------	--	--	--	--	--	--	--	--

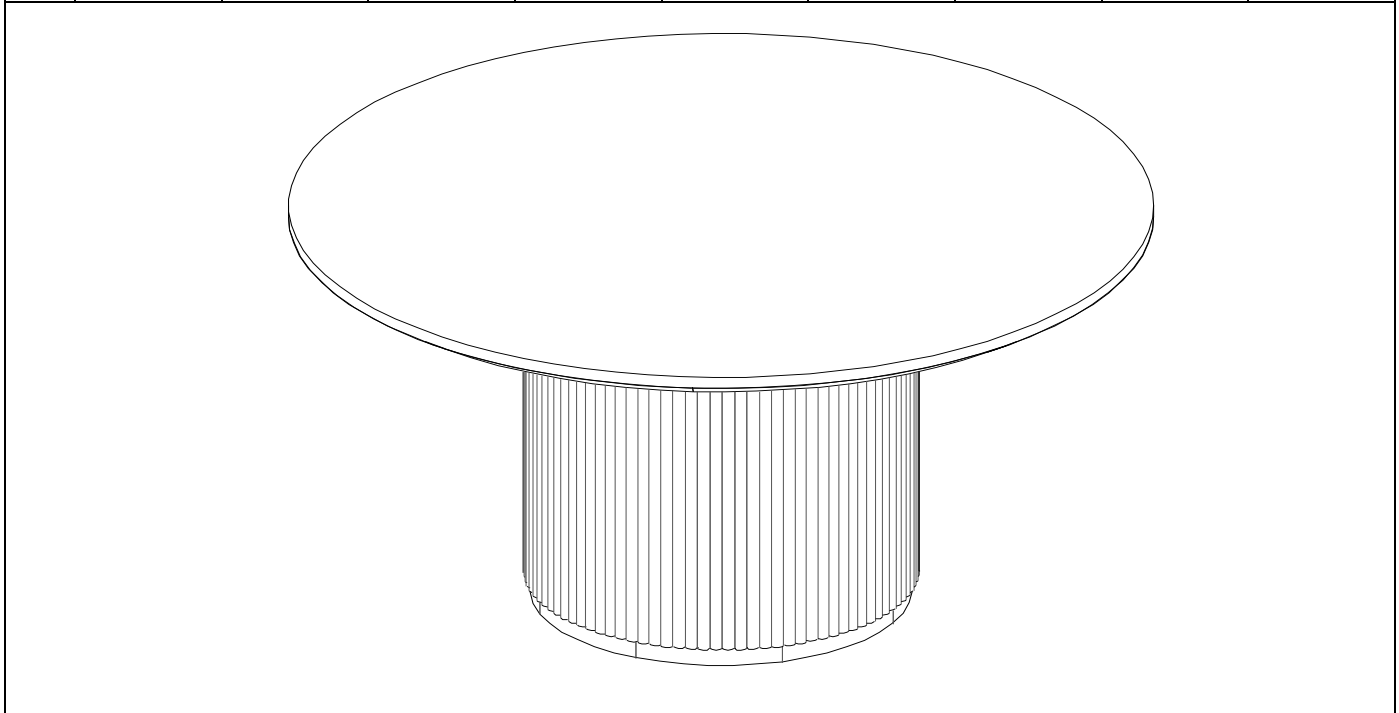

 <p>ASSEMBLY REQUIRES TWO PEOPLE</p>	 <p>15-MINUTE ASSEMBLY TIME</p>	 <p>KEEP INSTRUCTIONS FOR FUTURE USE</p>		
---	--	---	---	--

ASSEMBLY INSTRUCTIONS
SKU# 51031721

1

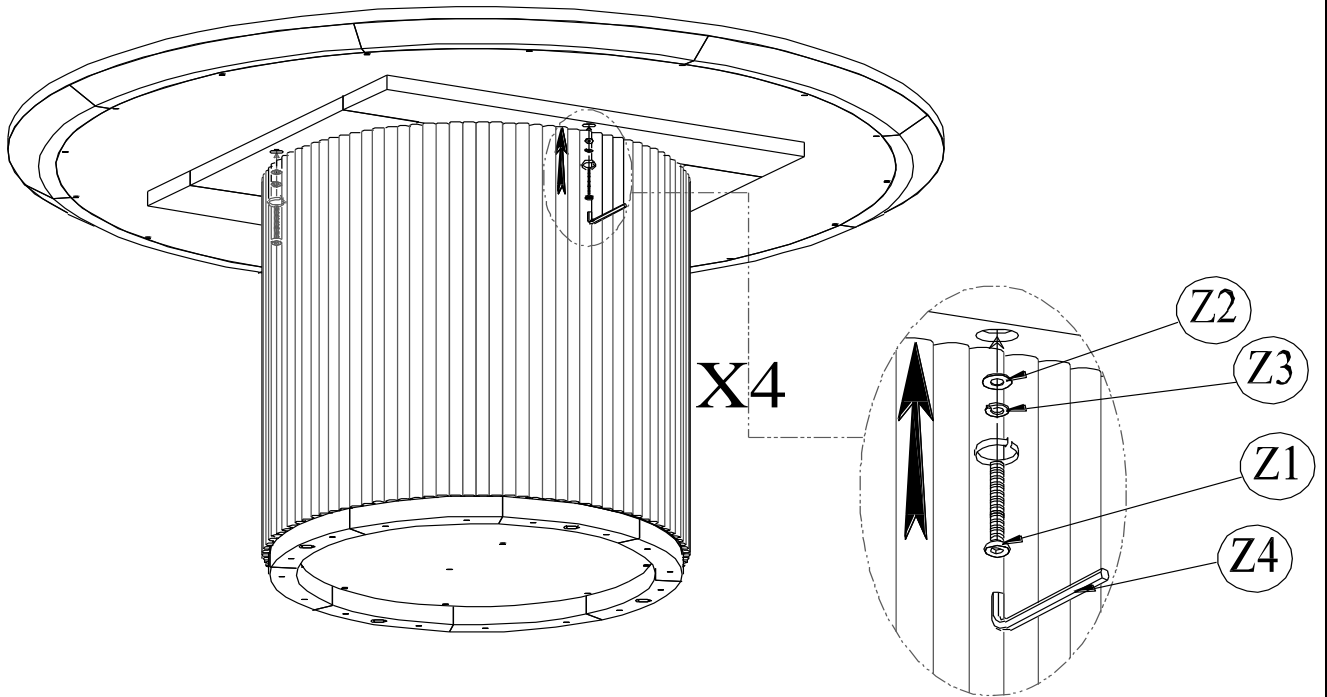

- Attach the Table Top (A) into the Table Leg (B).
- Using Allen Key (Z4) to tighten all Allen Bolts (Z1), Spring washers (Z3) and Washers (Z2).

2

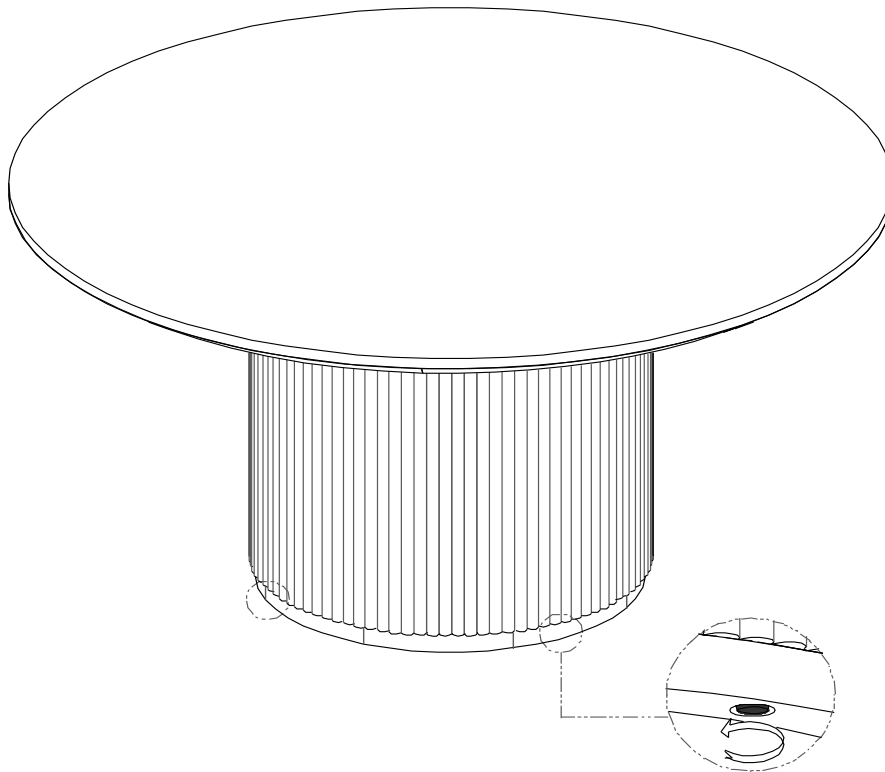

- If the table is not level, make adjustments by using the adjustable floor glides beneath the legs.
- Assembly Completed