







CARE AND MAINTENANCE

Spot clean using a mild water-free solvent. Only a professional cleaner should undertake a complete overall cleaning.
The use of steam or water-based cleaners may cause excessive shrinking or staining.

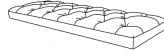
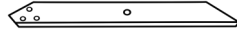
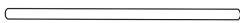
NOTICE

- * Please make sure that you have all parts indicated before you begin assembly of this item
- * This item should be assembled on a soft surface to prevent scratching the finish during assembly
- * This item may require periodic tightening

Part List and Hardware List

| PIECE | DESCRIPTION | PICTURE | QUANTITY |
|-------|--------------------|---|----------|
| A | Seat |  | 1X |
| B | Side Legs |  | 4X |
| C | Middle rod |  | 1X |
| E | Metal Gasket(M8) |  | 14X |
| F | Spring washer(M8) |  | 12X |
| G | Bolt(M8*40mm) |  | 12X |
| H | Bolt(M8*65mm) |  | 2X |
| J | Plastic Gasket(M8) |  | 2X |
| K | Allen key |  | 1X |

Dimensions: 48"W*18"D*18"H

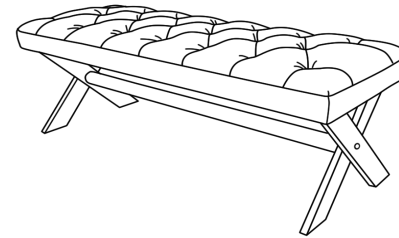

Weight Capacity: 275 lbs

WARNING: DO NOT STAND ON BENCH

WARNING: DO NOT OVER TORQUE BOLTS/SCREWS

The legs and hardware are located in the carton.

PREPARATION

Before beginning assembly of product, make sure all parts are present. Compare parts with package contents list and hardware contents list.

If any part is missing or damaged, do not attempt to assemble the product.

Estimated Assembly Time: 10 minutes.

Tools Required for Assembly (included): Allen key

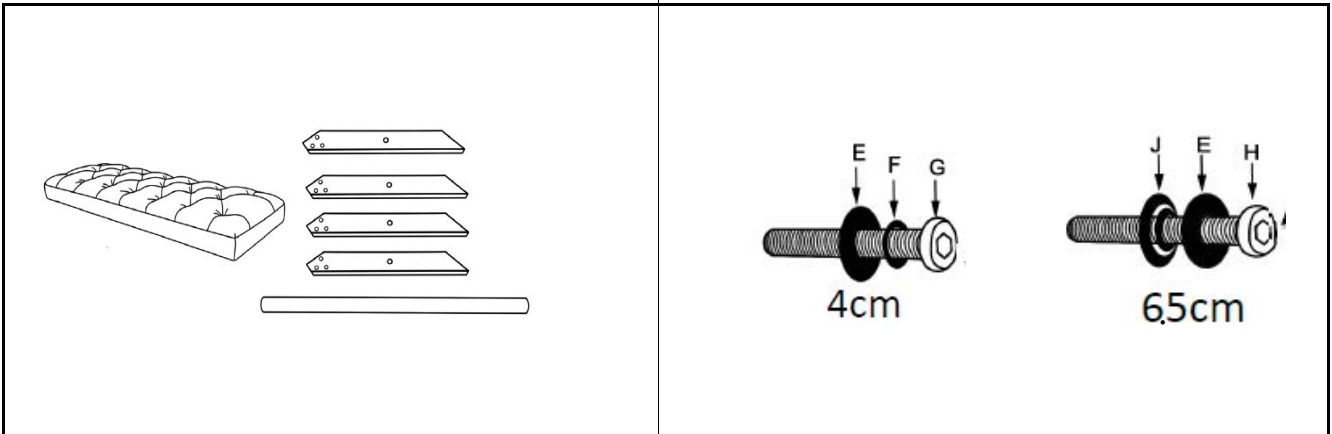

STEP1 Open the carton, you can find the bench seat , legs and hardware

STEP2 PUT THE WASHERS ON THE BOLT AS SHOWN IN THE PICTURE

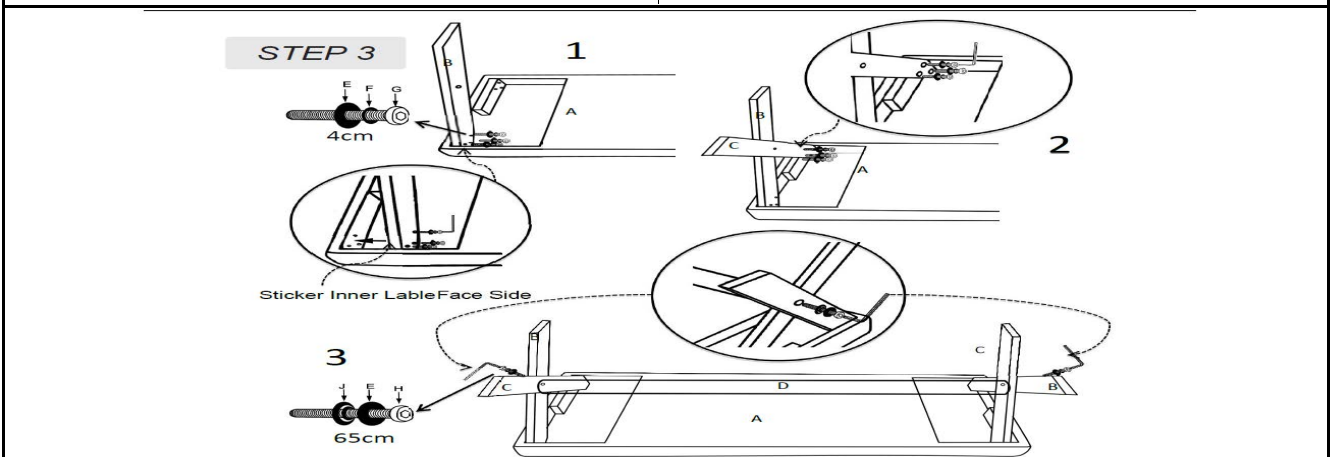

STEP3 INSERT THE LEGS AND SCREW IN THE BOLTS BUT DON'T TIGHTEN COMPLETELY. REPEAT THE SAME STEPS FOR THE OTHER THREE LEGS, THEN USE THE LONG SCREW TO CONNECT FOUR LEGS WITH THE MIDDLE ROD.

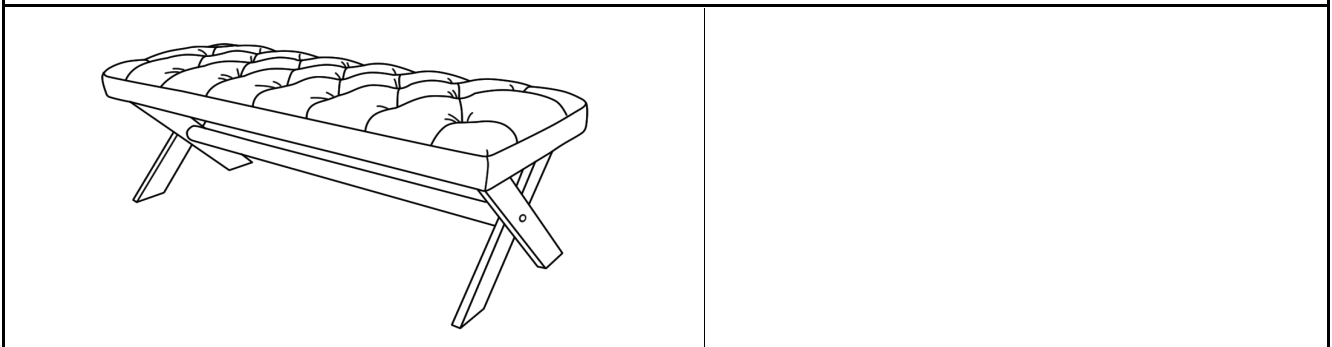

STEP4 PUT THE BENCH UPRIGHT AND MAKE SURE ALL LEGS ARE LEVEL, THEN FIRMLY TIGHTEN BOLTS WITH ALLEN KEY WHILE THE BENCH IS UPRIGHT AS PICTURED ABOVE