

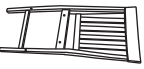

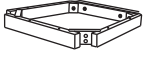











# Assembly Instruction

## SLAT BACK BARSTOOL WITH UPHOLSTERED SEAT

NO	Parts List	Q'TY
A	 Chair Back	1 pce
B	 Seat Frame	1 pce
C	 Upholstered seat	1 pce
D	 Left Front Leg	1 pce
E	 Right Front Leg	1 pce
F	 Left Side Stretcher	1 pce
G	 Right Side Stretcher	1 pce
H	 Front Stretcher	1 pce

NO	Hardware List	Q'TY
1	 8 x 1" Pan Head Screw	6 pcs
2	 8 x 1.1/4" Pan Head Screw	6 pcs
3	 M6x 40mm JCBC Bolt	2 pcs
4	 M6x70mm JCBC Bolt	6 pcs
5	 M6x13mm Lock Washer	8 pcs
6	 M6.5x16.5mm Flat Washer	8 pcs
7	 M4 x 2.1/2" Allen Key	1 pce
8	 Assembly Glue	1 pce

**Important Note**  
Do not use power tool for assembly.  
All bolt must fasten either by wrench or Allen Key.



### STEP 1 Do not fully tighten the bolt

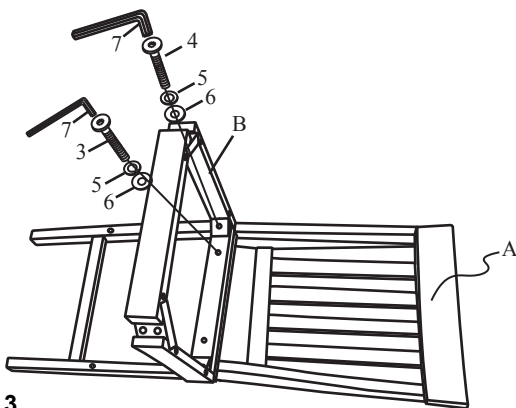

### STEP 2 Do not fully tighten the bolt

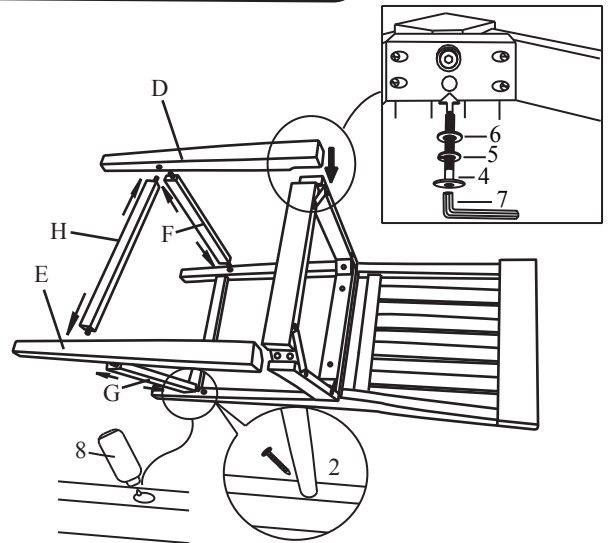

### STEP 3

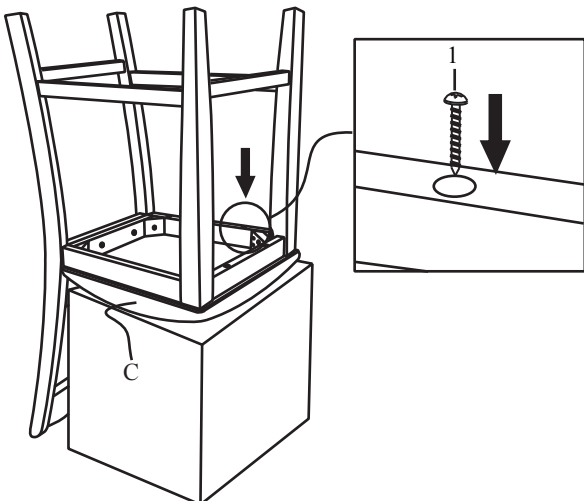

### STEP 4

Levelling solution: Loosen each bolt in the seat box (front legs, back corner blocks and back apron) to the point where it can be turned with our fingers. Place the Chair/Stool upright on the floor and make sure Chair/Stool back and seat frame are well connected. Sit in the Chair/Stool, but do not lean against the Chair/Stool back. Gently sway back and forth, left and right. Carefully turn the Chair/Stool upside down, and tighten each bolt. The Chair/Stool will now be levelled.

