

ASSEMBLY INSTRUCTION

NOTES:

- Do not skip any step.
- Do not fully tight screws until all the bed parts are assembled.

WARNING:







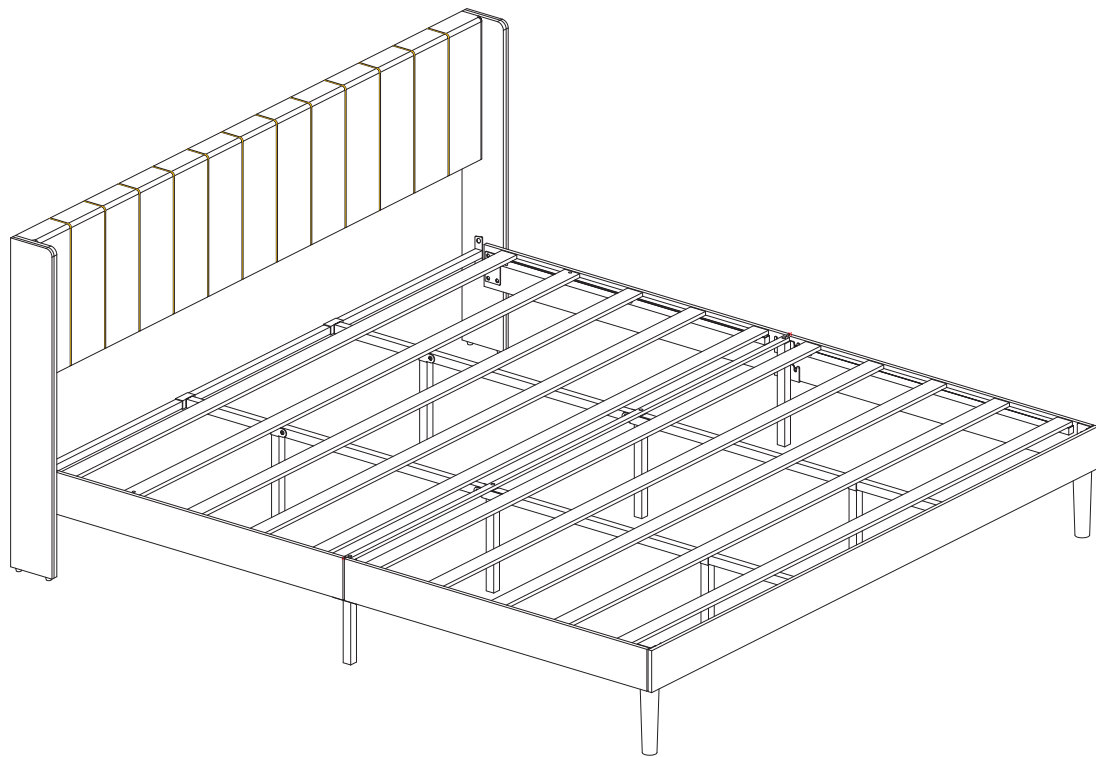

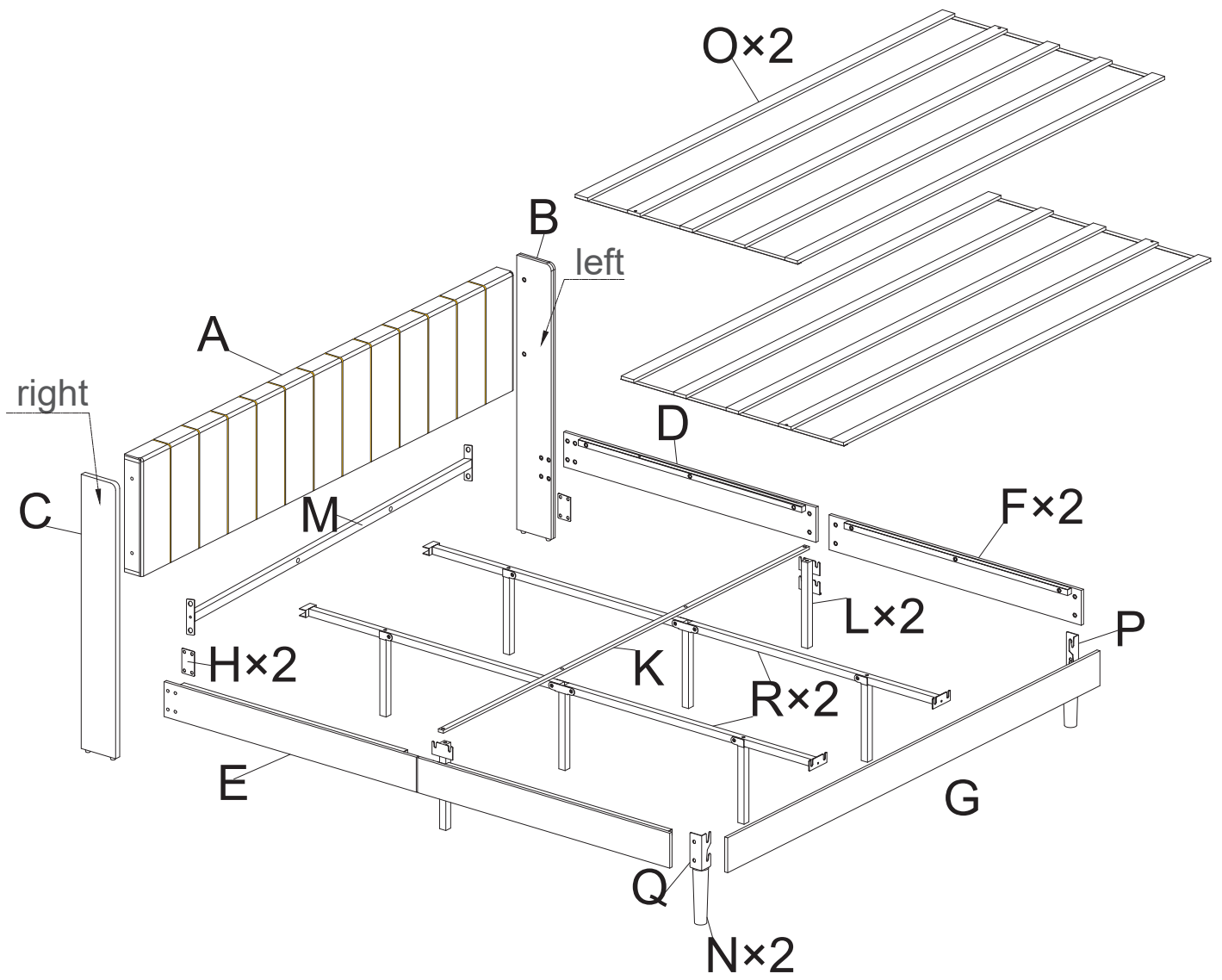

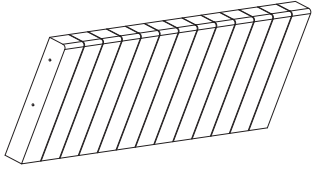

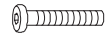

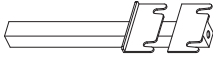



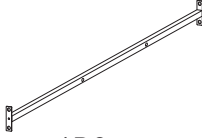

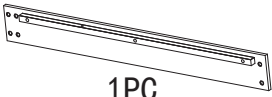

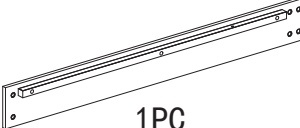
- WARNIND FOR YOUNG CHILDREN-This product contains small components,please ensure that they are kept away from small children while assembling.

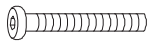

Warranty Information:

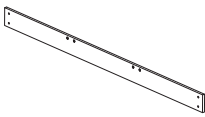
- We warranty this product to be free from defects in materials.



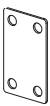
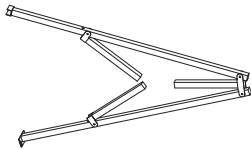



<p style="text-align: center;">A</p>	<p style="text-align: center;">K</p>	aa	 M6*55	8						
 <p style="text-align: center;">1PC</p>	 <p style="text-align: center;">1PC</p>	bb	 M8x20	4						
<p style="text-align: center;">B</p>	<p style="text-align: center;">L</p>	cc	 M8x32	14						
<p>left</p>  <p style="text-align: center;">1PC</p>	 <p style="text-align: center;">2PCS</p>	dd	 M8x15	20						
<p style="text-align: center;">C</p>	<p style="text-align: center;">M</p>	ee	 5mm	1						
<p>right</p>  <p style="text-align: center;">1PC</p>	 <p style="text-align: center;">1PC</p>	ff		8						
<p style="text-align: center;">D</p>	<p style="text-align: center;">N</p>									
 <p style="text-align: center;">1PC</p>	 <p style="text-align: center;">2PCS</p>				ii		2			
<p style="text-align: center;">E</p>	<p style="text-align: center;">O</p>									
 <p style="text-align: center;">1PC</p>	 <p style="text-align: center;">2PCS</p>							SPARE		
<p style="text-align: center;">F</p>	<p style="text-align: center;">P</p>	aa		1						
 <p style="text-align: center;">2PCS</p>	 <p style="text-align: center;">1PC</p>	bb		1						
<p style="text-align: center;">G</p>	<p style="text-align: center;">Q</p>	cc		1						
 <p style="text-align: center;">1PC</p>	 <p style="text-align: center;">1PC</p>	dd		1						
<p style="text-align: center;">H</p>	<p style="text-align: center;">R</p>	ff		1						
 <p style="text-align: center;">2PCS</p>	 <p style="text-align: center;">2PCS</p>									
					3/9					

CC	 M8x32	4
ee	 5mm	1
ff		4

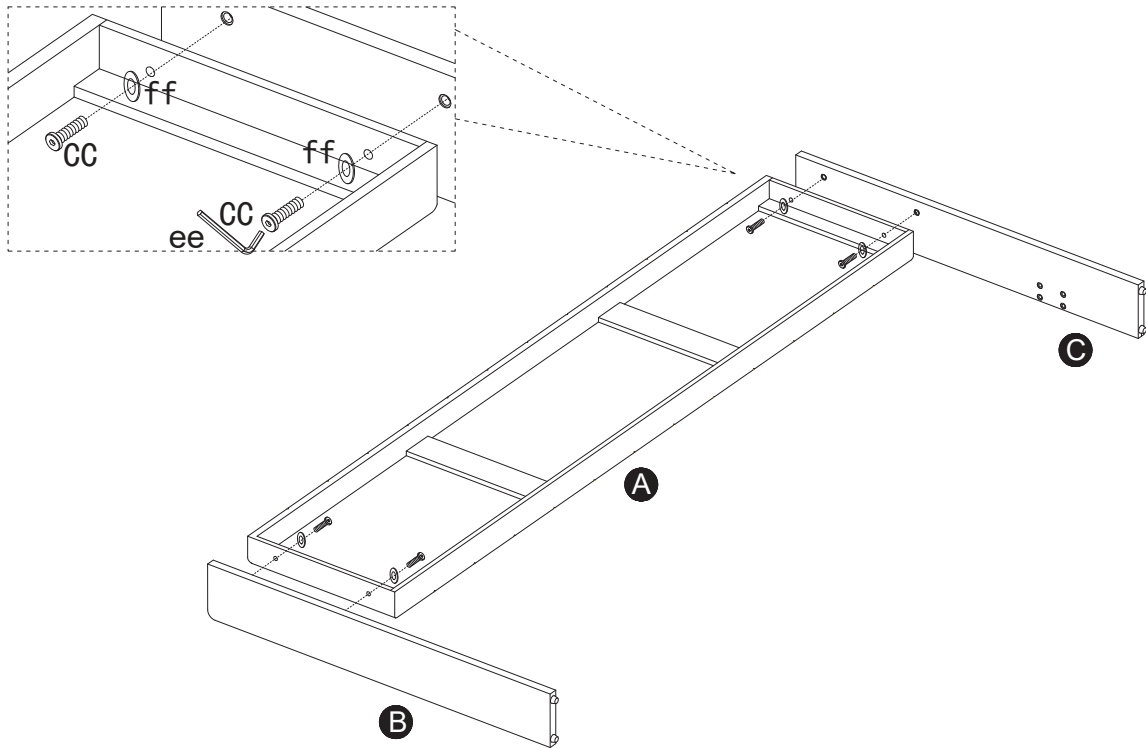
Step 1





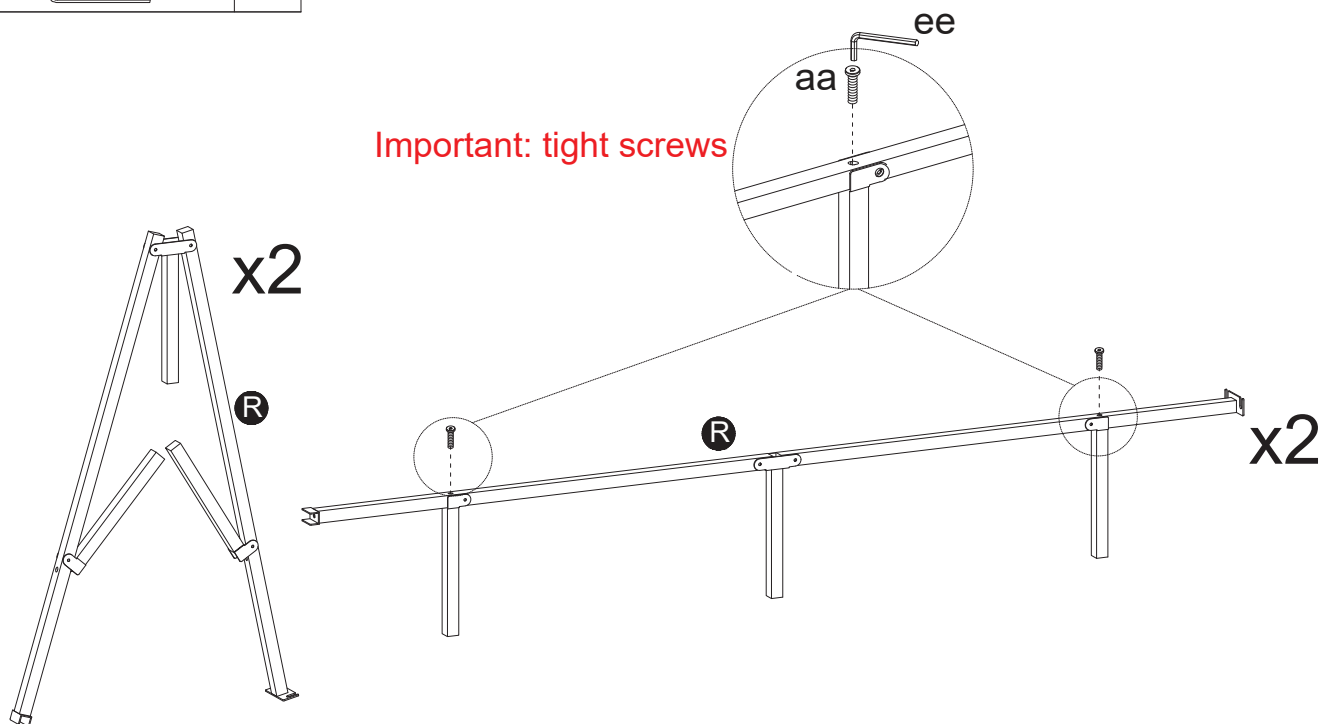

aa	 M6x55	4
ee	 5mm	1

Step 2





Step 3

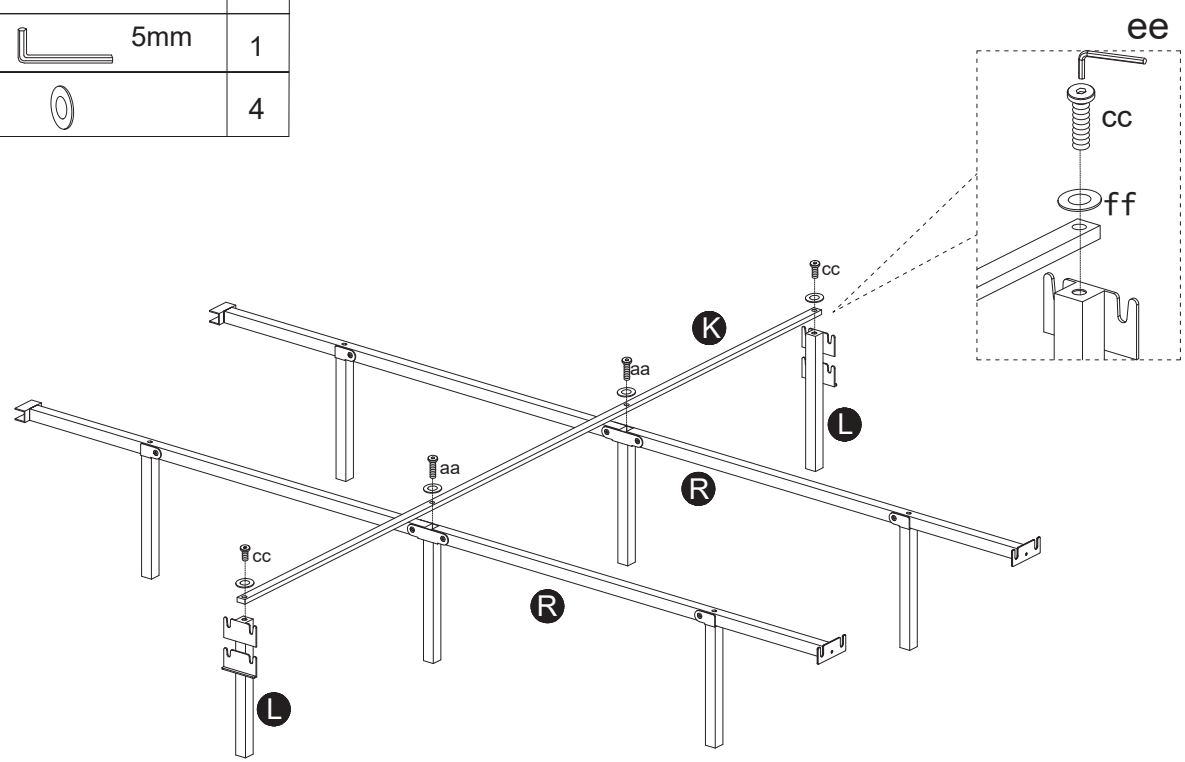

aa		M6x55	2
cc		M8x32	2
ee		5mm	1
ff			4



Step 4

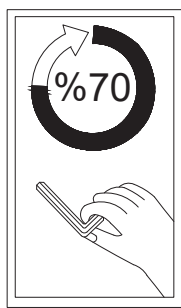
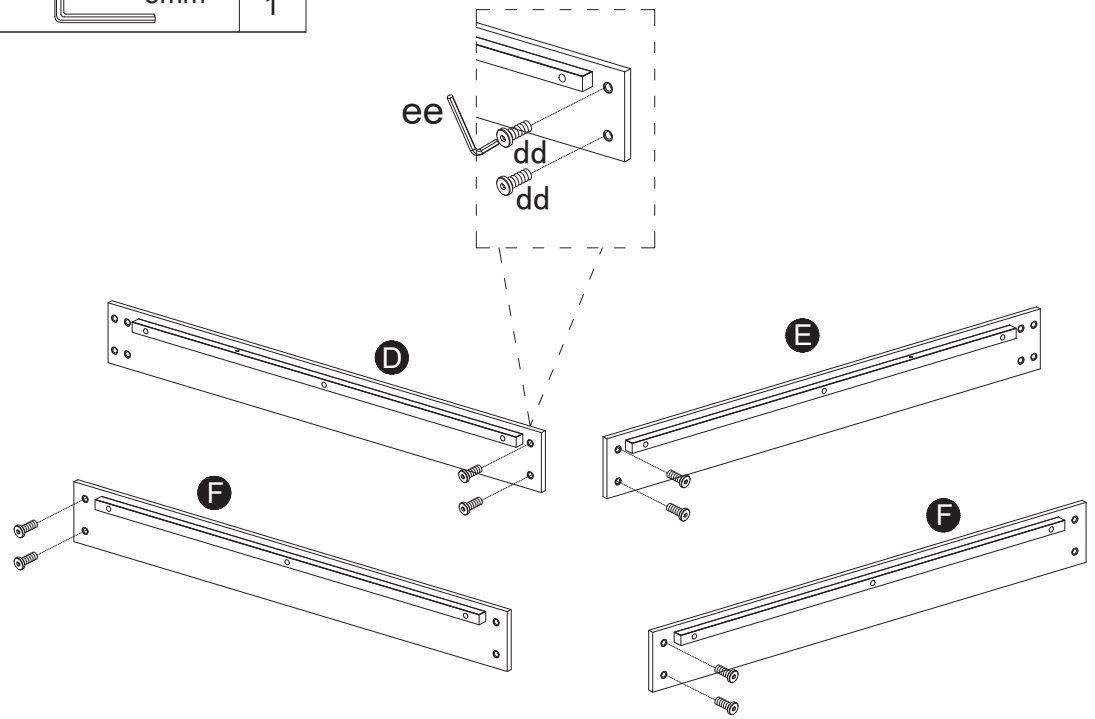

dd		M8x15	8
ee		5mm	1

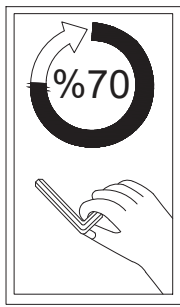
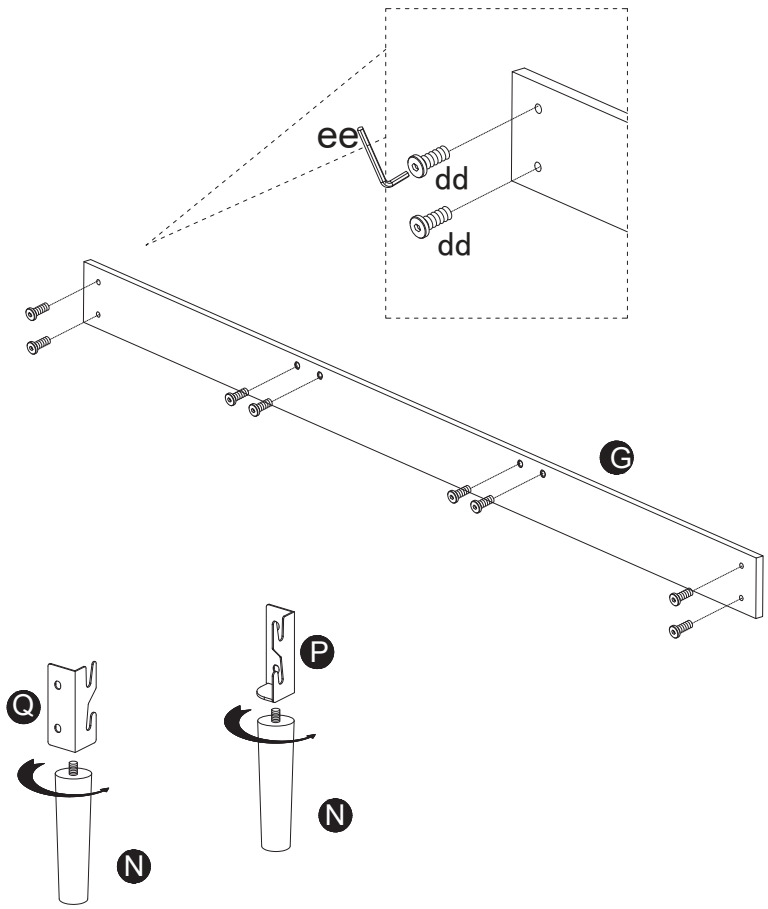

dd	 M8x15	8
ee	 5mm	1

Step 5



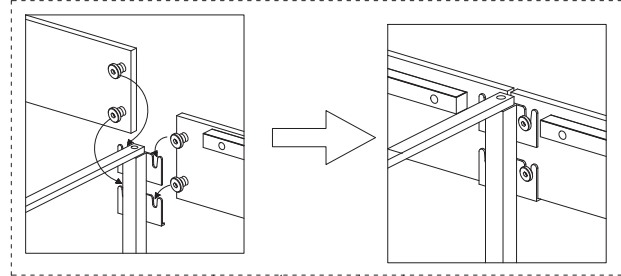
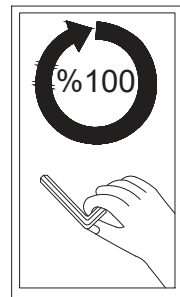

dd	 M8x15	4
ee	 5mm	1

Step 6

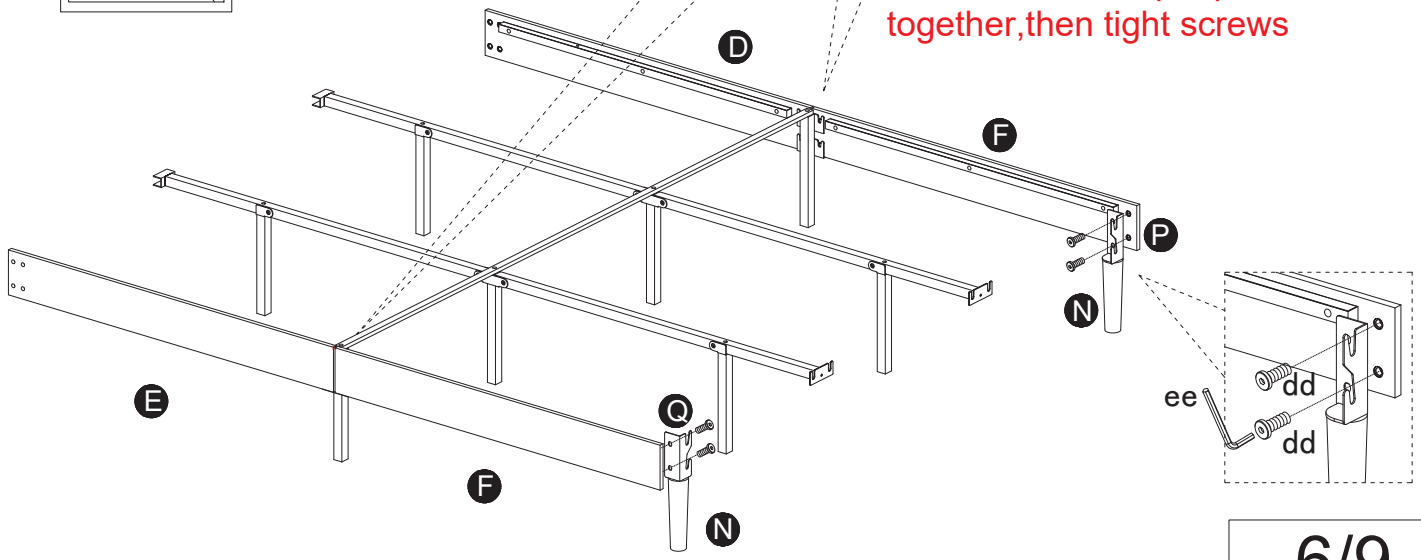

Release screws, put part together, then tight screws



ee	 5mm	1
cc	 M8x32	8

Step 7

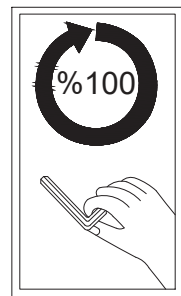
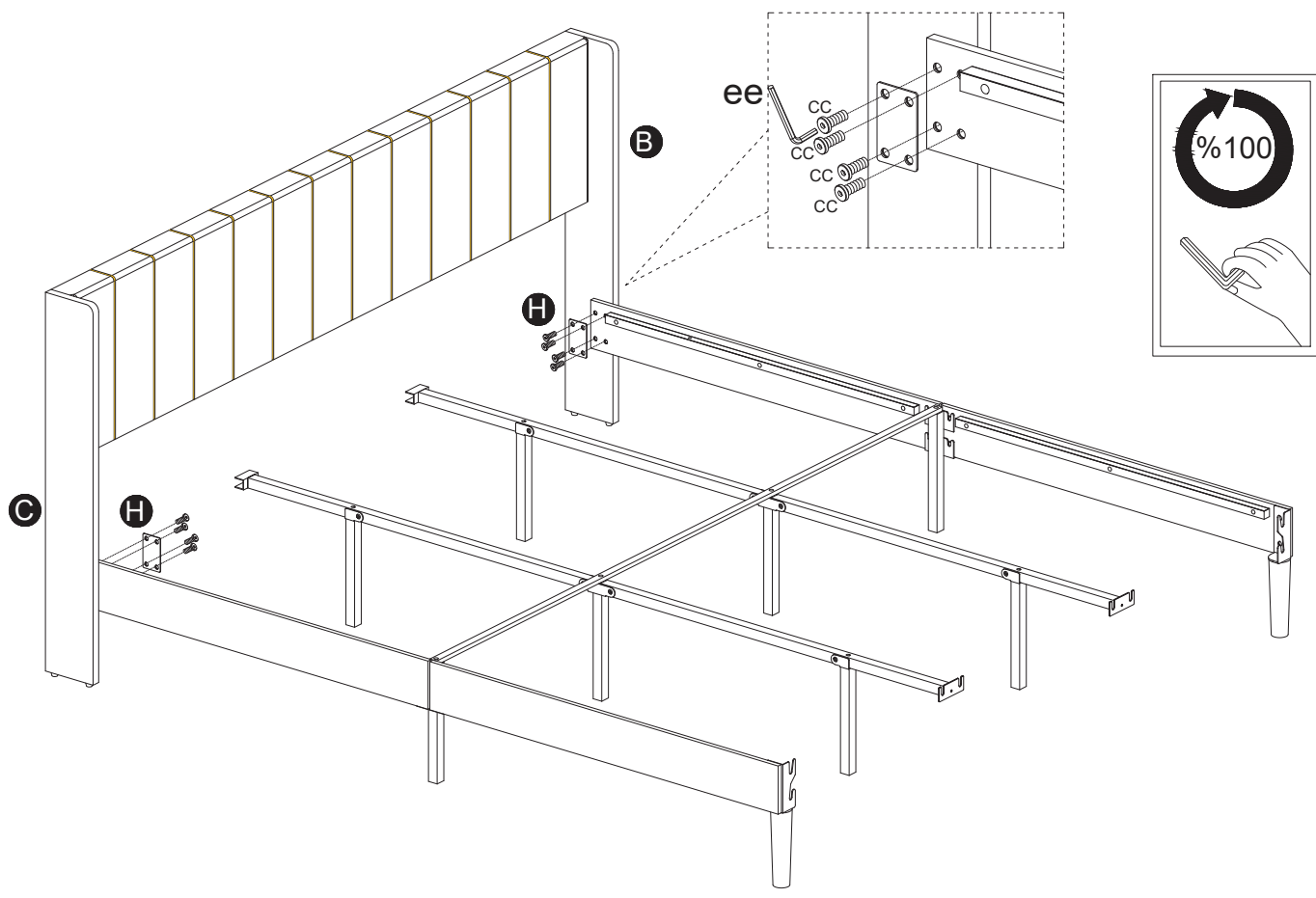

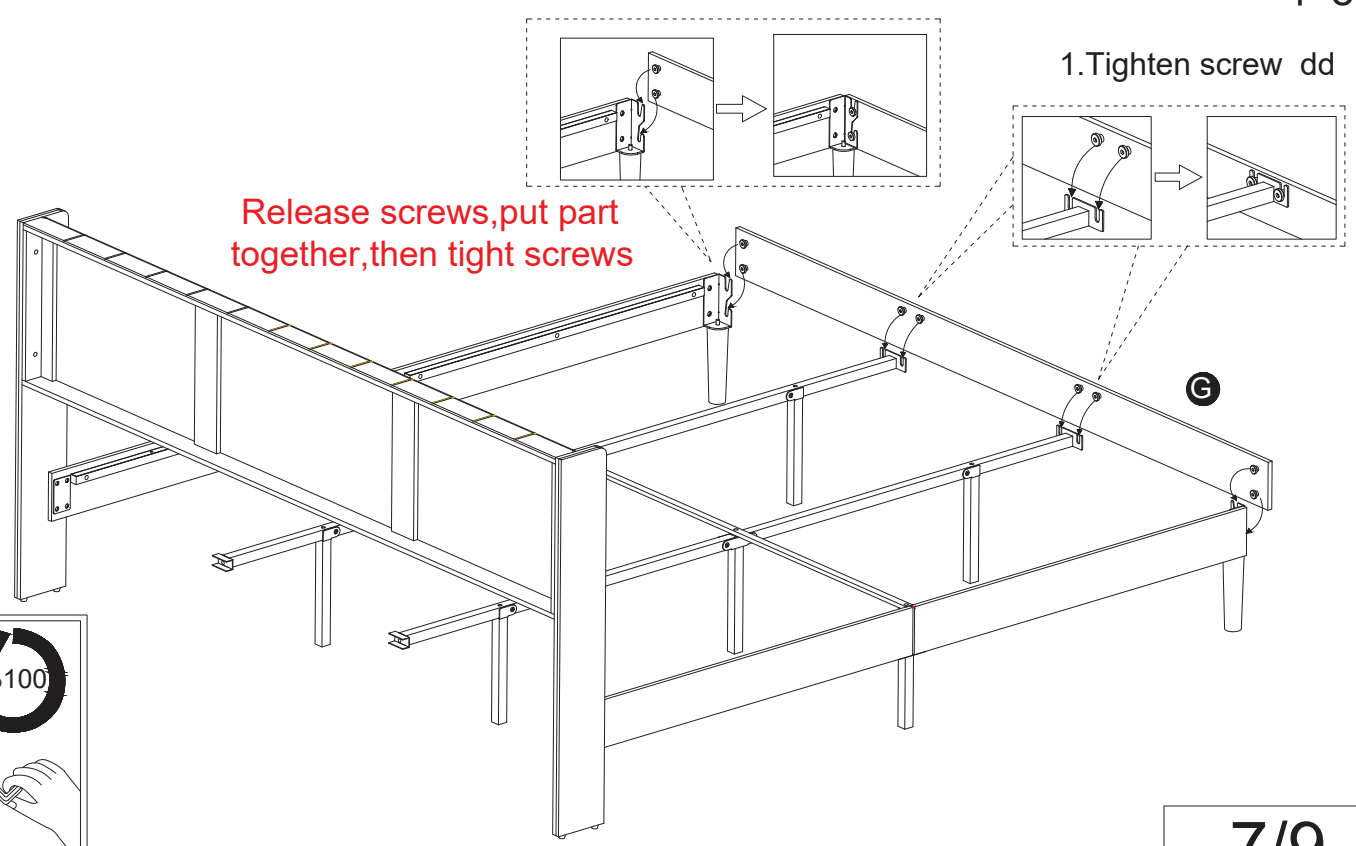

Step 8

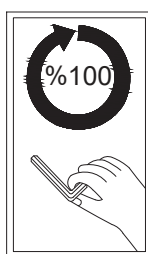

1. Tighten screw dd



aa		M6x55	2
bb		M8x20	4
ee		5mm	1

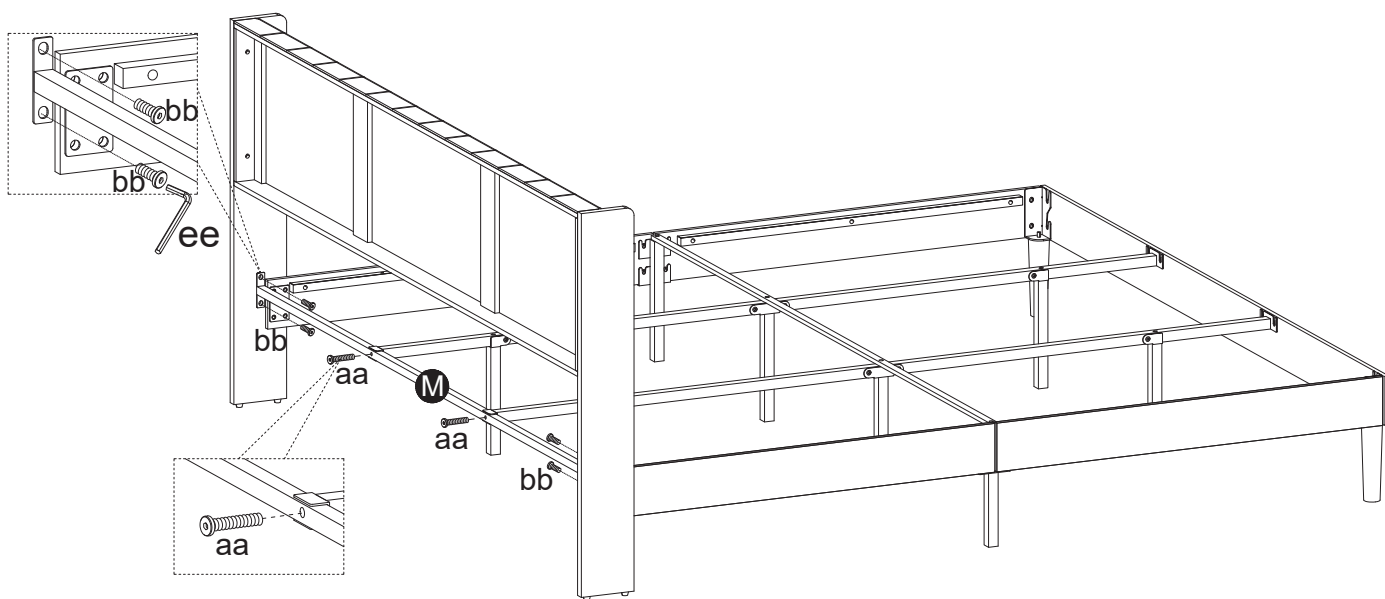

ii		2
----	---	---

To prevent friction noise, unroll part ii and fit it on part R. the length of part ii can cut as you will.

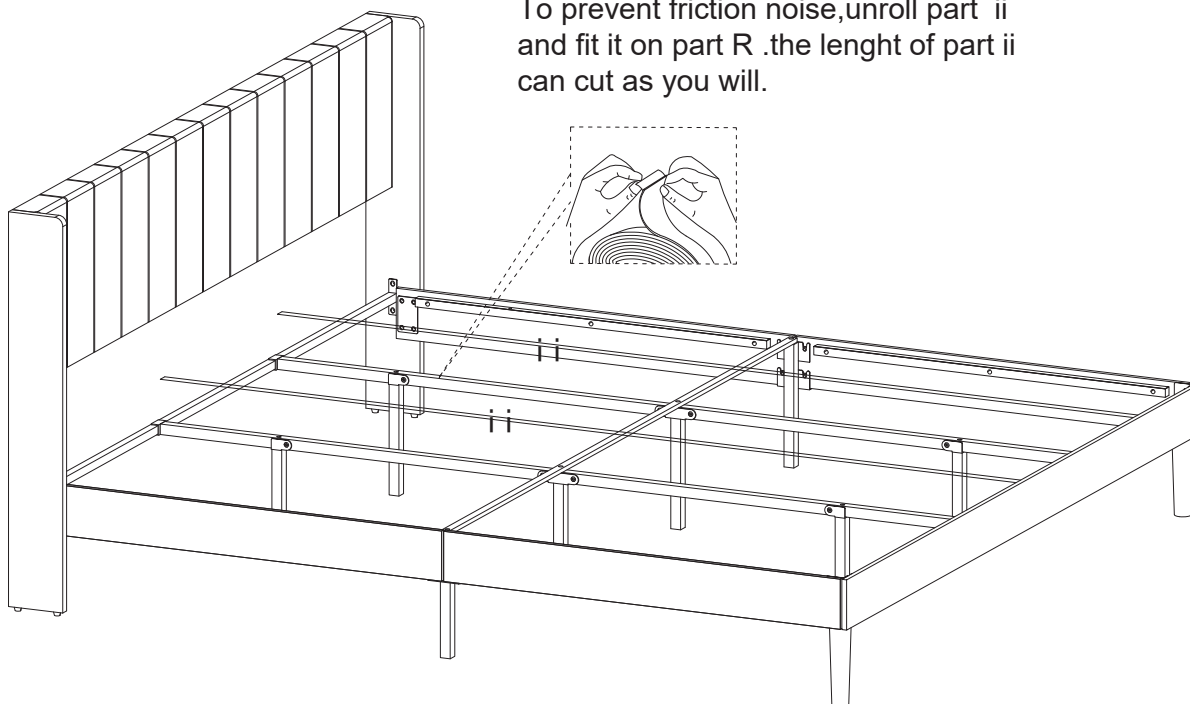

Step 11

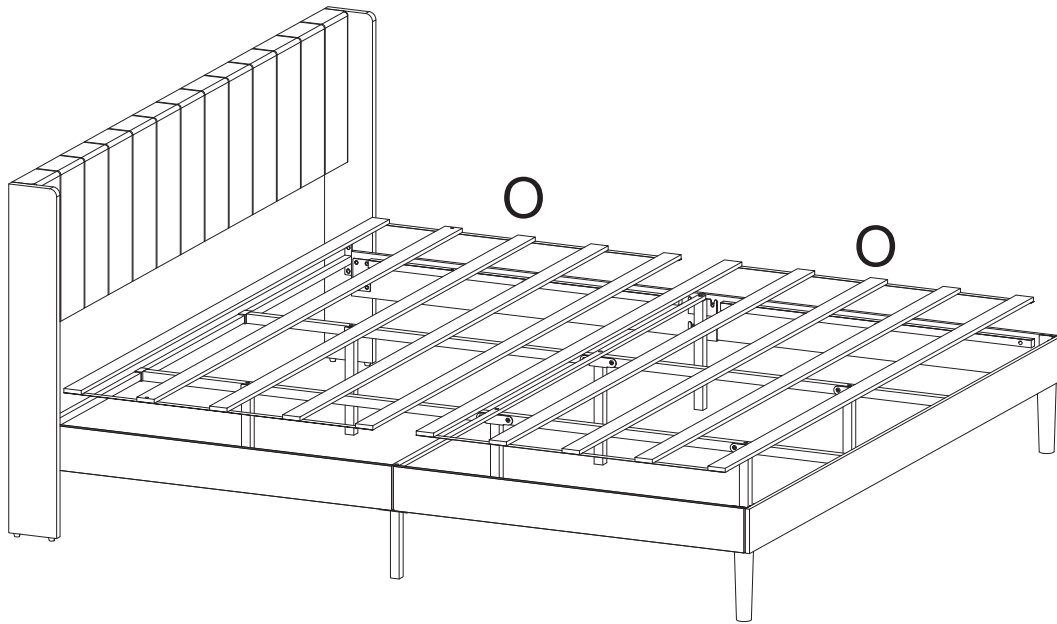

Step 12

