











Assembly Instructions

Caution : You must read this before you proceed



Care & Maintenance

-  ● Not for commercial use. For residential use only.
-  ● Furniture may scratch floors. We recommend using furniture pads to protect your floors.
-  ● Do not put hot items directly on furniture surface.
-  ● Do not clean furniture with harsh cleansers or polish.
-  ● Do not place furniture under direct sunlight.
-  ● Do not place furniture near heating or cooling vents.
-  ● Do not write on furniture without a padded barrier to protect the surface.
-  ● Do not place furniture outside. For indoor use only.
-  ● Stains may be removed with mild soap solution and damp cloth.
-  ● Children should not climb or jump on the furniture.
-  ● Dust and pick-up spills using a clean, non-colored, lint-free cloth.

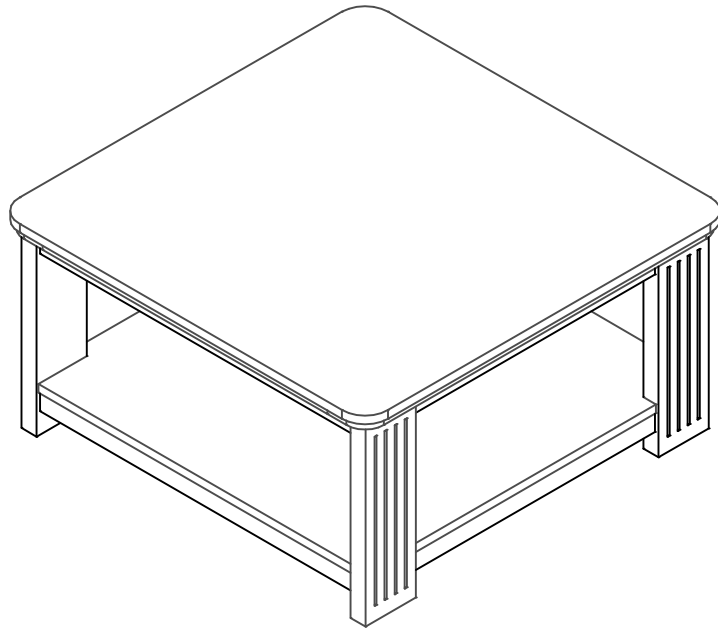
Coffee Table

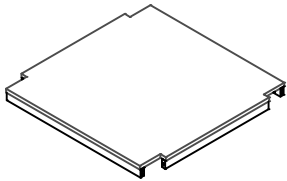

Parts List







| Label | Picture | Description | QTY |
|-------|---|----------------|-----|
| A |  | Table Top | 1 |
| B |  | Lower Shelf | 1 |
| C |  | Left Table Leg | 2 |

| | | | |
|---|---|-----------------|---|
| D |  | Right Table Leg | 2 |
|---|---|-----------------|---|

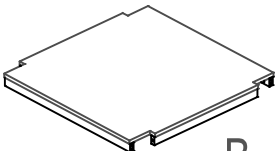
Hardware

| Label | Picture | Description | QTY |
|-------|---|------------------------|-----|
| ① |  | Allen Wrench M4 x110mm | 1 |
| ② |  | JCBC Bolt M6x50mm | 16 |
| ③ |  | Spring Washer WS6 | 16 |
| ④ |  | Wooden Dowel M8x30mm | 8 |

Assembly Preparation

| | | | | |
|----------------------------|--|---|---|--|
| Before Beginning Assembly: |  |  |  |  |
| |  X1 |  X16 |  X16 |  X8 |



- Read Instructions, cover to cover-



- Have 2 adults on hand for assembly-



- Do not assemble on flooring or carpet-



- Assemble on a clean non-marring surface (packing foam)-



- Save all packaging until finished-

Assembly Steps

Overview

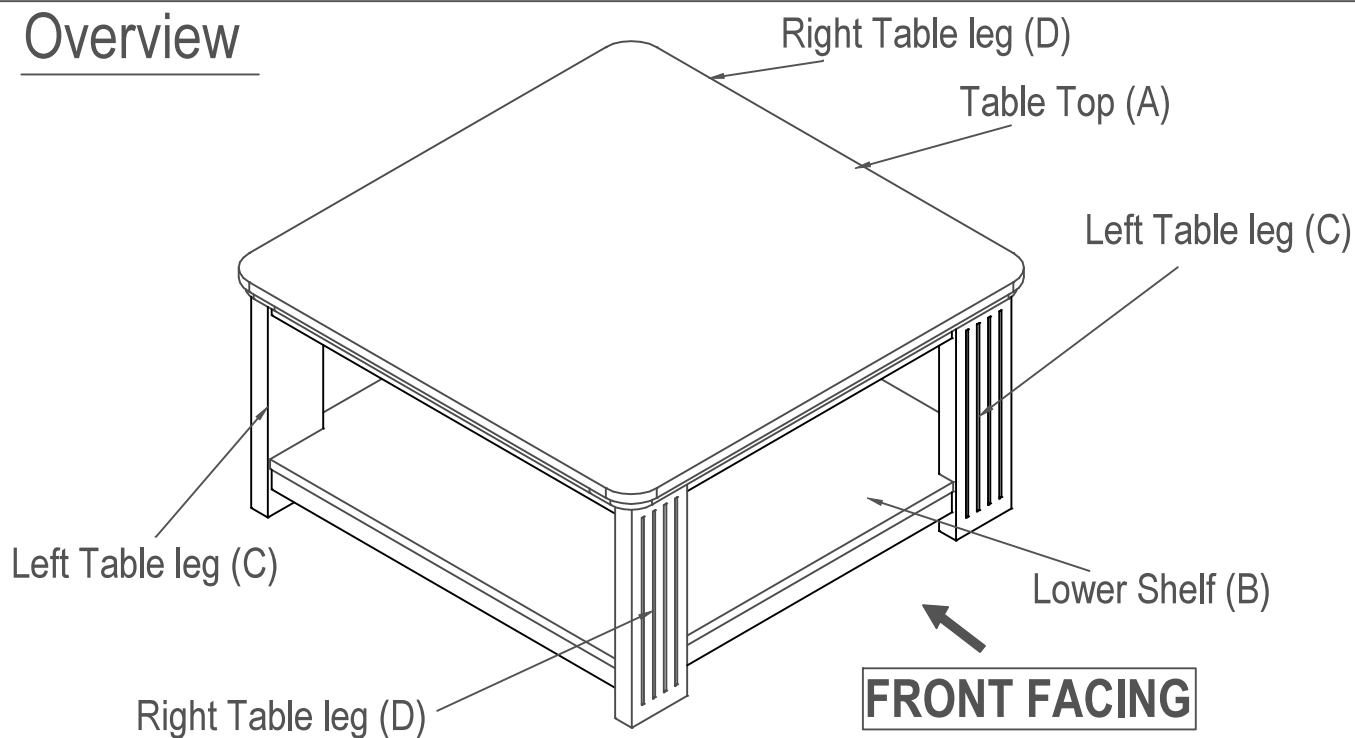

This coffee table has multiple parts and may require up to 30 minutes to assemble. To give you an overview of the Coffee Table, the above picture is to help you put the various parts into perspective. Please read through the instructions herebelow to familiarise the parts and steps before assembly.

Step

1

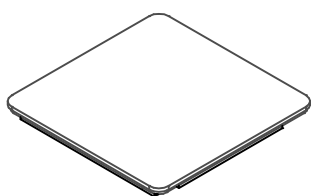

A

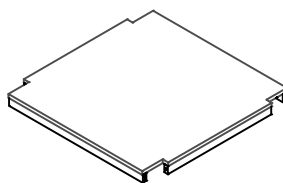

B



C



D

Unpack and place all parts on a clean, non-marring surface.

Step
2

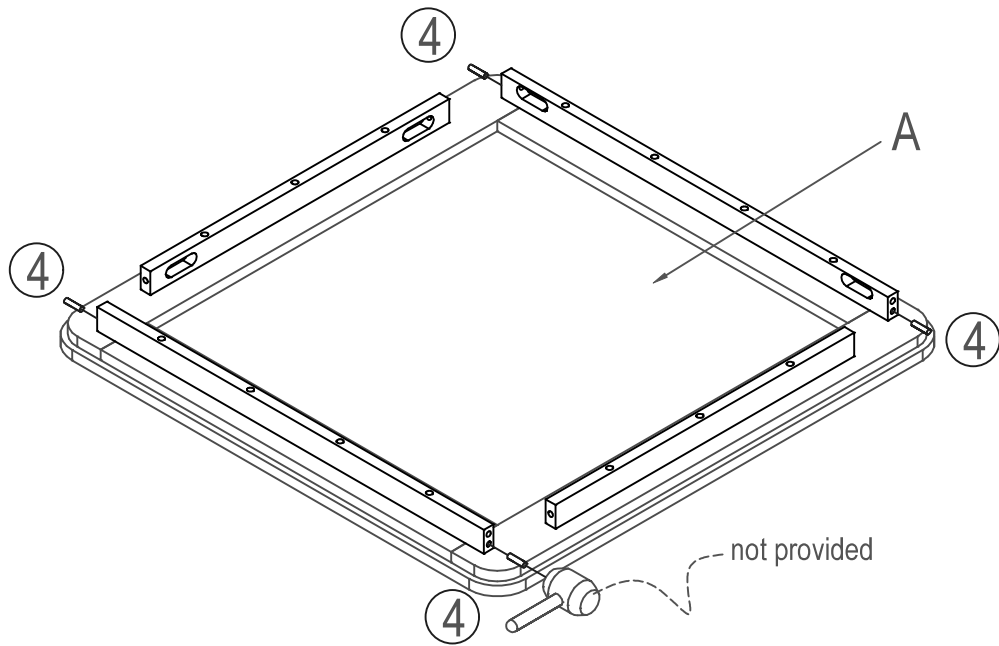

Insert Wooden Dowels (④) into the pre-drilled holes along the long frame of the Table Top (A). Press fully into place.

Step
3

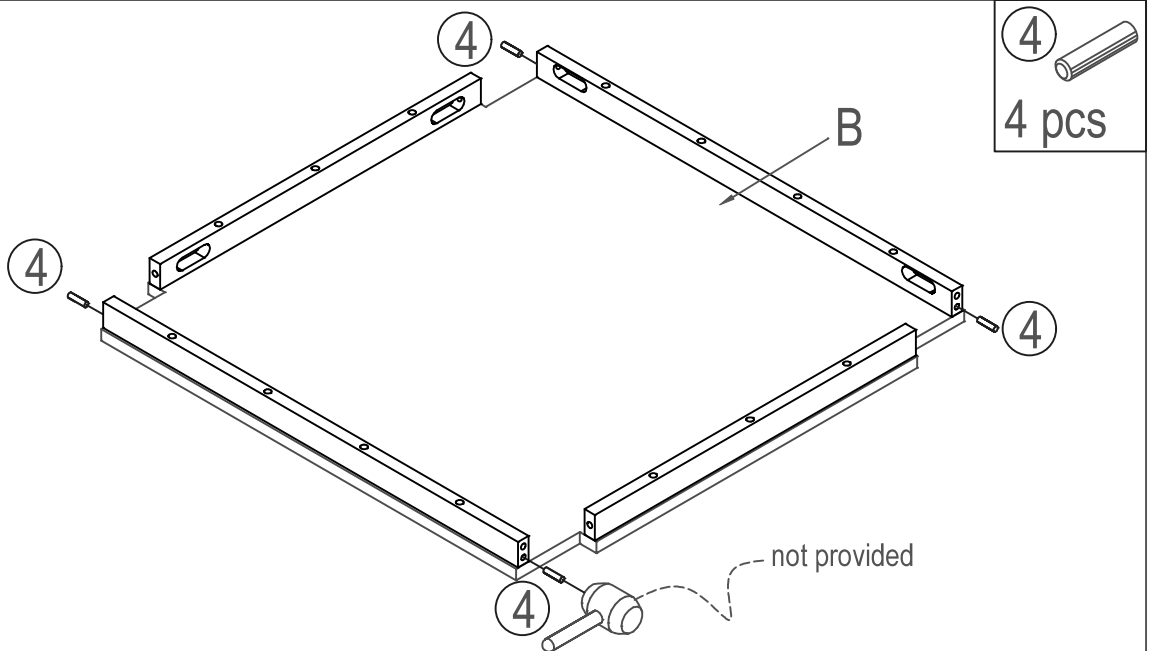

Repeat the same step for the long frame of the Lower Shelf (B). Insert Wooden Dowels (④) and press fully into place.

Step
4

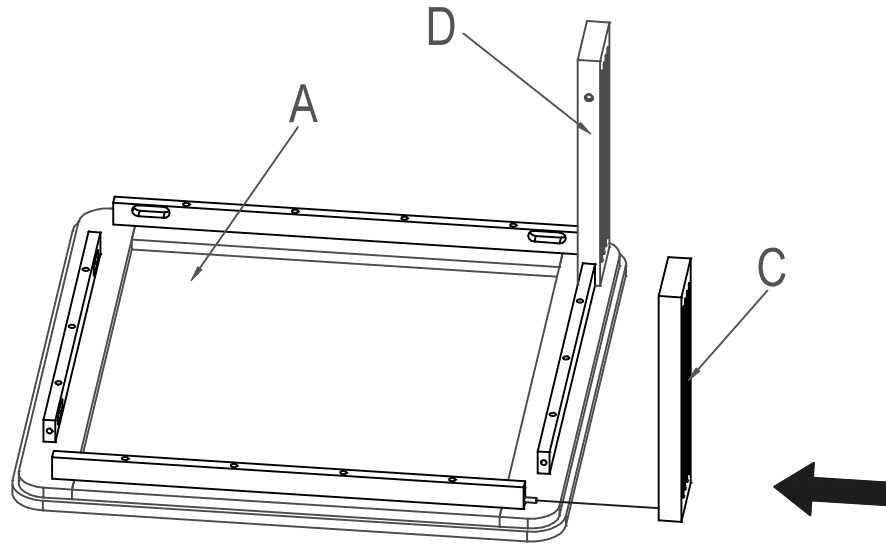

Position the Left Table Leg (C) and Right Table Leg (D), so that the pre-drilled holes align with the installed Wooden Dowels (④) on the Table Top (A). Ensure all dowels are properly seated in the holes before proceeding to secure the legs.

Step
5

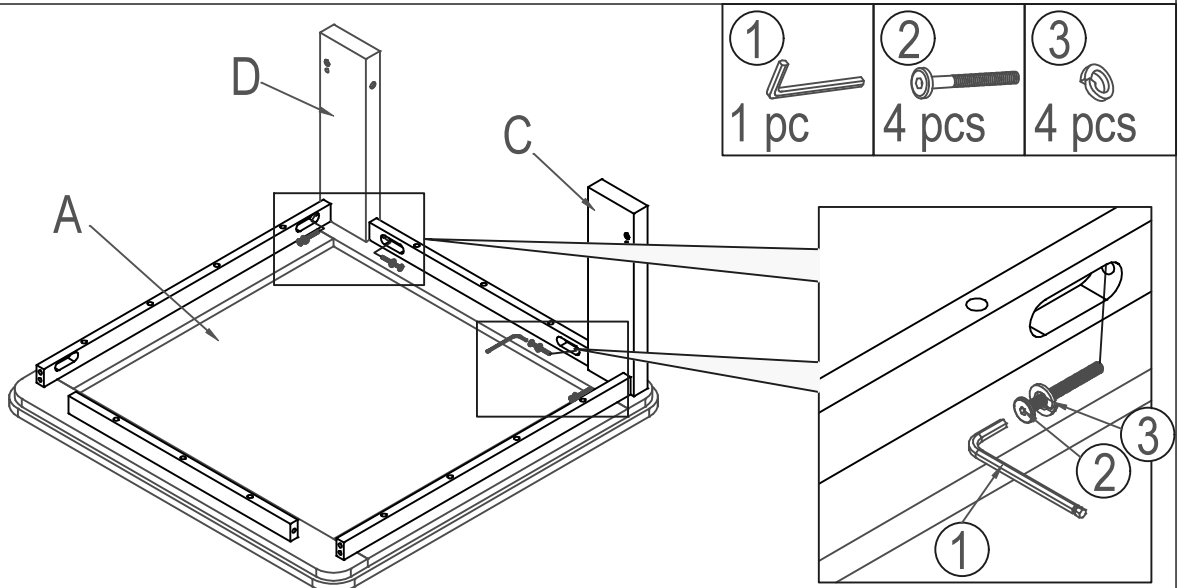

Fasten the Table Legs (C) and (D) to the Table Top (A) using JCBC Bolts (②) and Spring Washers (③). Tighten securely with the Allen Wrench (①). Ensure all legs are properly aligned before fully tightening.

Step
6

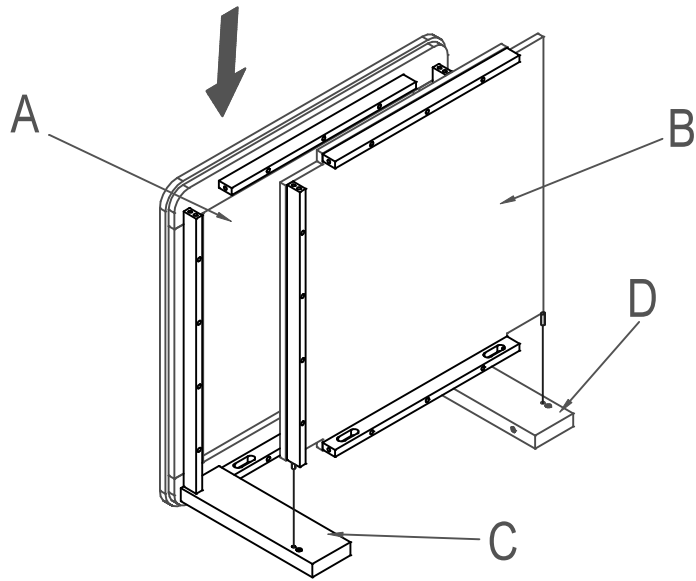

Position the Lower Shelf (B) so that the installed Wooden Dowels (④) align with the pre-drilled holes on the Left Table Legs (C) and Right Table Leg (D). Ensure all dowels are fully inserted and the shelf sits flush with the legs before proceeding to secure it.

Step
7

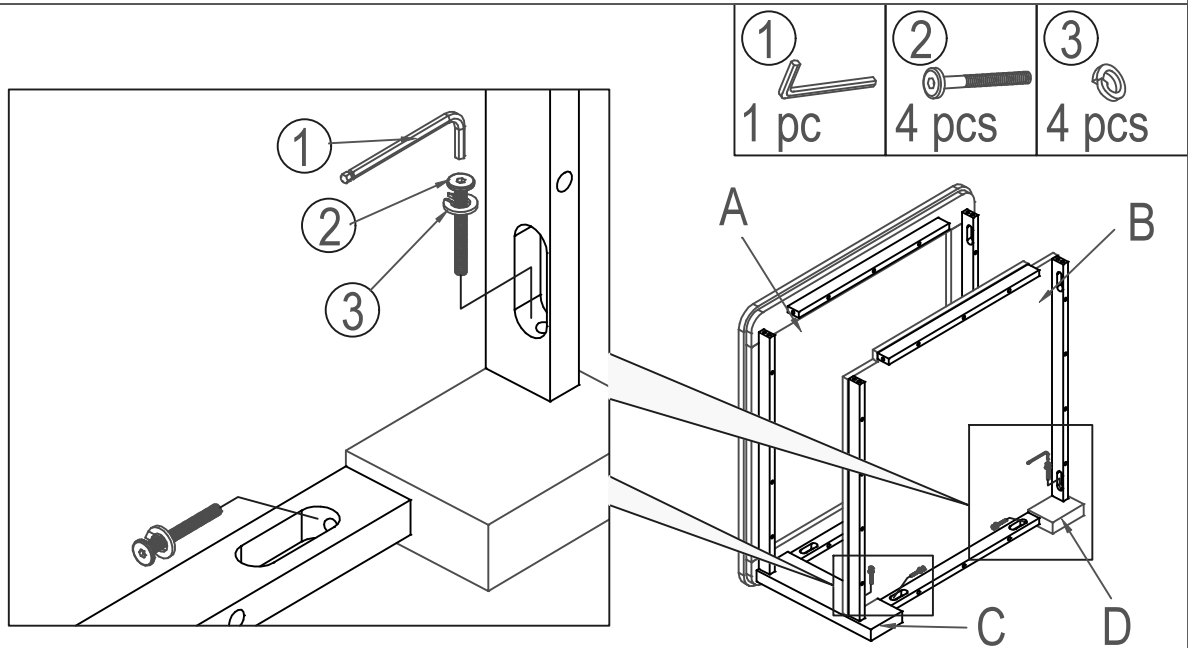

Secure Lower Shelf (B) to Left Table Legs (C) and Right Table Leg (D) using JCBC Bolts (②) and Spring Washers (③). Tighten with Allen Wrench (①).

Step
8

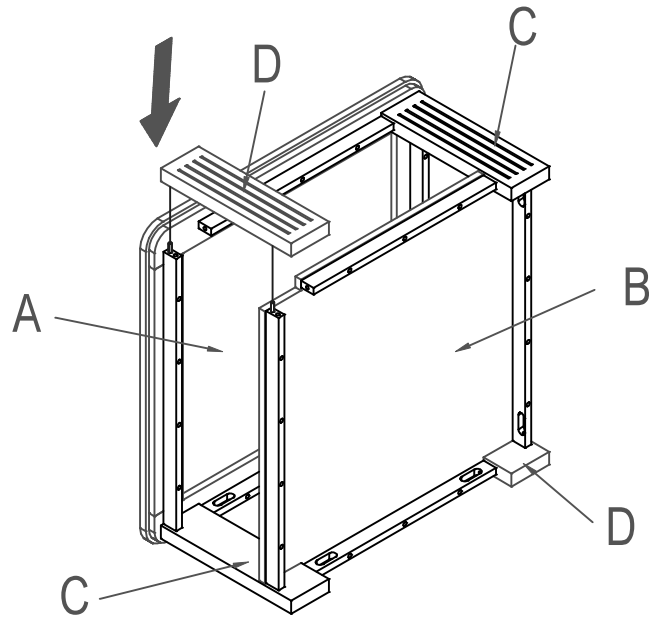

Align the remaining Left Table Legs (C) and Right Table Leg (D), with the installed Wooden Dowels (④) on the Table Top (A) and Lower Shelf (B). Confirm proper fit before fastening.

Step
9

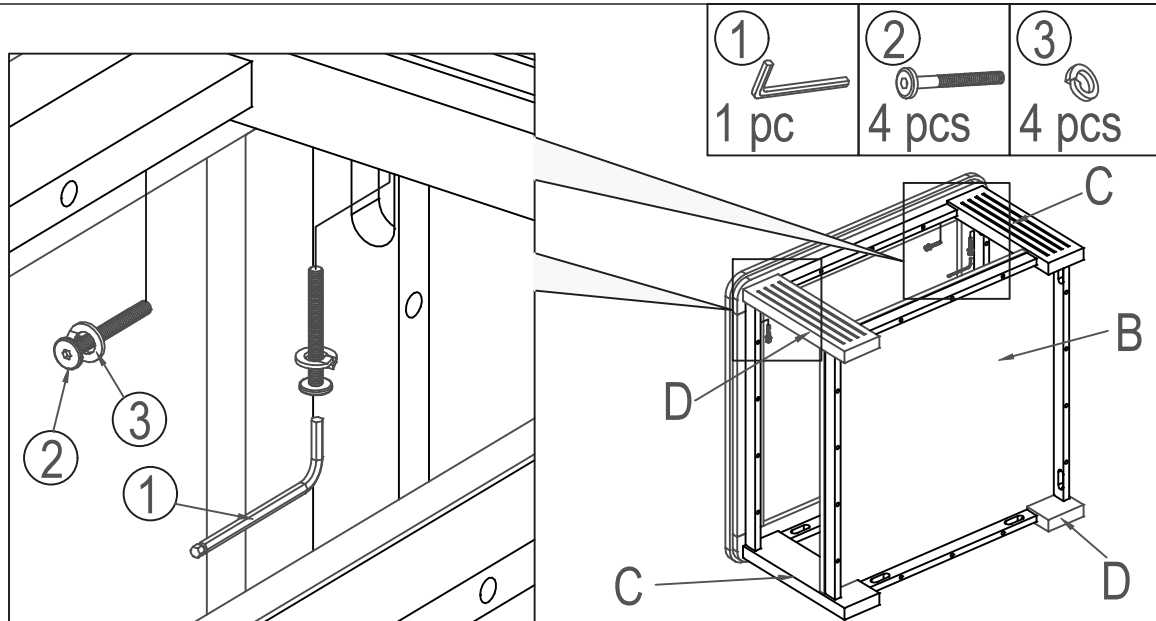

Secure the Left Table Legs (C) and Right Table Leg (D), to the Table Top (A) using JCBC Bolts (②) and Spring Washers (③). Tighten with the Allen Wrench (①). Ensure proper alignment before fully tightening.

Step
10

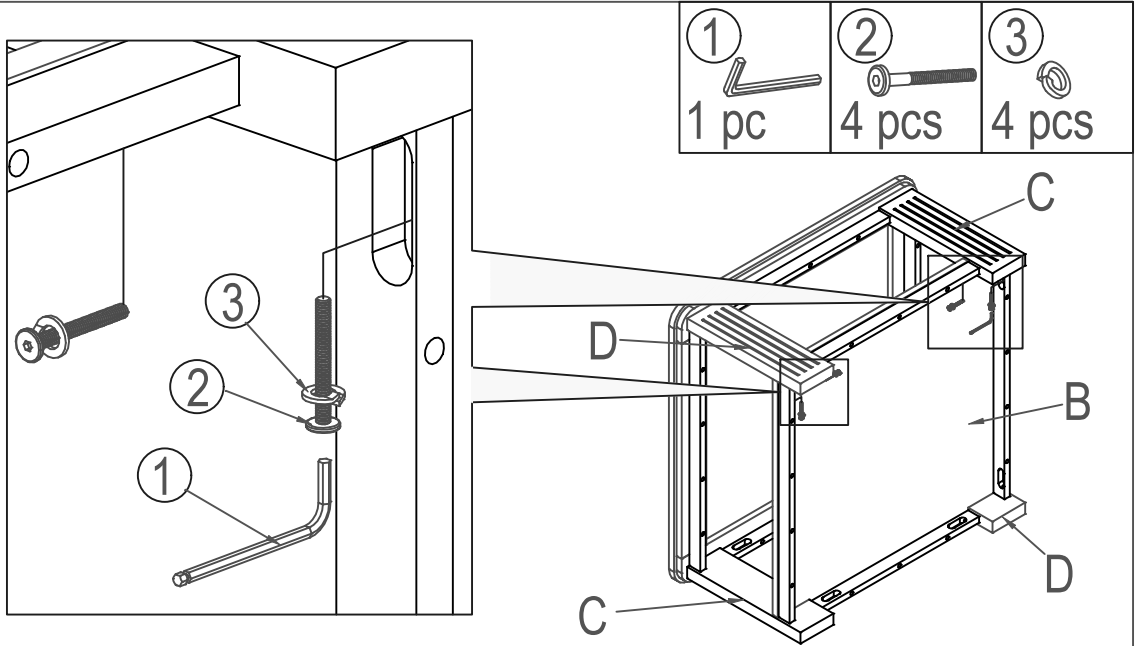

Secure the Left Table Legs (C) and Right Table leg (D), to the Lower Shelf (B) using JCBC Bolts (2), and Spring Washers (3). Tighten with the Allen Wrench (1). Ensure proper alignment before fully tightening.

Please arrange the table parts and equipment before starting the assembly.

Place the Coffee Table on a LEVEL SURFACE.

Inspect it and make sure all parts are adequately connected.

This would help to align all the parts at all the joint areas.

To tighten the bolts at the base, do secure assistance from your adult partner(s).

You may be required to turn the Coffee Table, to gain easy access to the secure points.

CAUTION 1: When tightening these bolts, tighten sequentially. Do not tighten the any bolts fully and then towards the next one. This would cause the frame to warp.

If these is still wobbles, loosen the bolts and execute this same process.

WARNING!! IF COFFEE TABLE IS NOT STABLE, IT COULD LEAD TO DAMAGE THE PRODUCT.

Ensure all bolts are fully locked into position.

The Coffee Table is ready to be used.

CAUTION 2: This Coffee Table can only be used on a flat, level surface.