

## Assembly Instructions

Your product comes package, carefully remove all of the components from the packing and set aside for assembly. Assemble on a soft surface to prevent scratching the finishing during assembly.

### CAUTION:

Tighten all components securely before use. Failure to do so may result in personal injury.

**DO NOT** use any sharp objects to open plastic wrapped components as damage to product or components may result.

### WARNING



Injury may result from tipping furniture.

You must install the Tipping Restraint Hardware with the unit to preset the unit from tipping and causing any accidental injury, stability, death or damage. The tipping restraint is intended only as a safety measure, it is not a substitute for proper adult supervision.

This tipping restraint is not an earthquake restraint. If you wish to add the extra security of earthquake restraints, they must be purchased and installed separately. Do not allow children to climb on furniture.

Failure to detach this restraint before moving furniture may result in injury and damage.

### AVERTISSEMENT

Le basculement du meuble peut entraîner des blessures

Vous devez installer la quincaillerie antibasculement pour éviter que l'unité bascule et cause des blessures accidentelles, l'invalidité, la mort ou des dommages.

La quincaillerie antibasculement est un moyen de protection. Elle ne constitue pas un substitut à la supervision d'un adulte. La quincaillerie antibasculement ne constitue pas un dispositif antisismique. Si vous voulez obtenir la sécurité accrue que procure un dispositif antisismique, vous devez l'acheter séparément et l'installer. Ne laissez jamais les enfants monter sur le meuble. Tout défaut de détacher la quincaillerie avant de déplacer le meuble peut causer des blessures et des dommages.

### ADVERTENCIA

Una lesión puede ser resultado por inclinación de muebles.

Debe instalar el juego de restricción de movimiento con la unidad funcionando para evitar que la unidad se vuelque y causar alguna lesión accidental, invalidez, muerte o daños.

La restricción está destinada sólo como una medida de seguridad, no es un sustituto de la supervisión de un adulto.

La restricción no es recomendable para usar como restricción contra terremoto. Si desea agregar mayor seguridad de restricciones contra terremoto, deben comprarse e instalarse por separado. No permita que los niños se suban a los muebles. El no desconectar este sistema de seguridad antes de mover los muebles, pueden producir lesiones y daños.

(1)X1

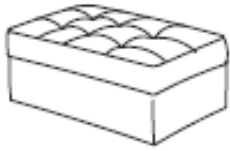

(2)X4

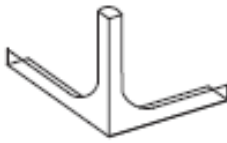

(3)X8



(4)X8



(5)X1



①

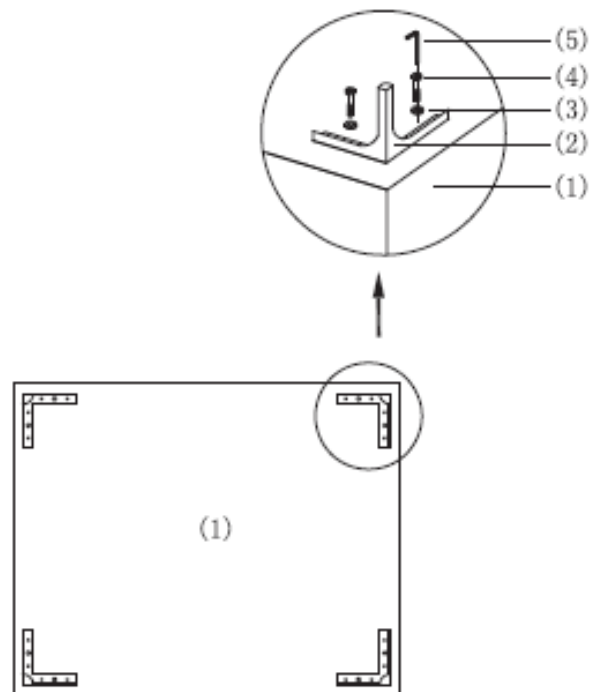

②

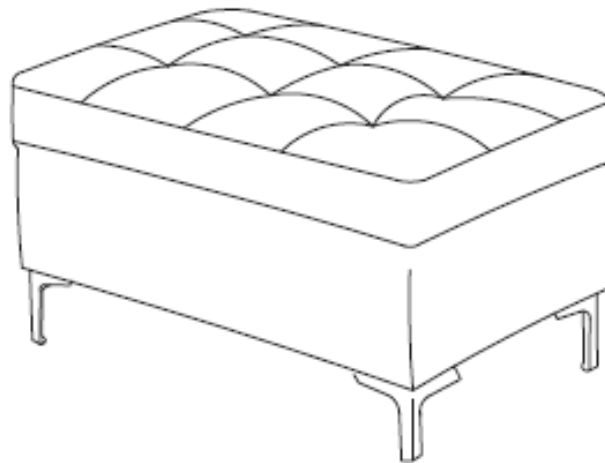

---

## Assembly Instructions

Your product comes package, carefully remove all of the components from the packing and set aside for assembly. Assemble on a soft surface to prevent scratching the finishing during assembly.

### CAUTION:

Tighten all components securely before use. Failure to do so may result in personal injury.

**DO NOT** use any sharp objects to open plastic wrapped components as damage to product or components may result.

### WARNING



Injury may result from tipping furniture.

You must install the Tipping Restraint Hardware with the unit to preset the unit from tipping and causing any accidental injury, stability, death or damage. The tipping restraint is intended only as a safety measure, it is not a substitute for proper adult supervision.

This tipping restraint is not an earthquake restraint. If you wish to add the extra security of earthquake restraints, they must be purchased and installed separately. Do not allow children to climb on furniture.

Failure to detach this restraint before moving furniture may result in injury and damage.

### AVERTISSEMENT

Le basculement du meuble peut entraîner des blessures

Vous devez installer la quincaillerie antibasculement pour éviter que l'unité bascule et cause des blessures accidentelles, l'invalidité, la mort ou des dommages.

La quincaillerie antibasculement est un moyen de protection. Elle ne constitue pas un substitut à la supervision d'un adulte. La quincaillerie antibasculement ne constitue pas un dispositif antisismique. Si vous voulez obtenir la sécurité accrue que procure un dispositif antisismique, vous devez l'acheter séparément et l'installer. Ne laissez jamais les enfants monter sur le meuble. Tout défaut de détacher la quincaillerie avant de déplacer le meuble peut causer des blessures et des dommages.







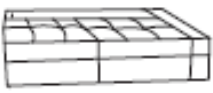

### ADVERTENCIA

Una lesión puede ser resultado por inclinación de muebles.

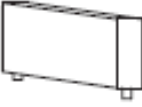
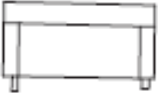
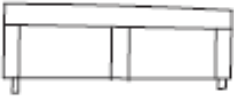
Debe instalar el juego de restricción de movimiento con la unidad funcionando para evitar que la unidad se vuelque y causar alguna lesión accidental, invalidez, muerte o daños.

La restricción está destinada sólo como una medida de seguridad, no es un sustituto de la supervisión de un adulto.

La restricción no es recomendable para usar como restricción contra terremoto. Si desea agregar mayor seguridad de restricciones contra terremoto, deben comprarse e instalarse por separado. No permita que los niños se suban a los muebles. El no desconectar este sistema de seguridad antes de mover los muebles, pueden producir lesiones y daños.

(1)X1 	(2)X1 	(3)X2 	(4)X1 	(5)X1 
(6)X2 	(7)X1 	(8)X2 	(9)X4 	(10)X18 
(11)X18 	(12)X1 