



ATTENTION!

If any components of this unit are broken, do not operate properly, or for product returns, please contact Weston Products LLC
Phone: 1-800-814-4895 (Outside the U.S. 440-638-3131)
20365 Progress Drive, Strongsville, Ohio 44149
WestonProducts.com

All Trademarks and Registered Trademarks are property of the respective companies.

SAVE THESE INSTRUCTIONS!

Refer to them often and use them to instruct others.



9" (22.9 CM)

MEAT SLICER

MODEL NO. 61-0901-W



Household Use Only
AC 120V~60Hz 150W

REV010411

CAUTION! It is important to follow the "Food Safety" guidelines outlined in this manual. For the most up to date instruction visit the USDA website.

! WARNING! Before cleaning, assembling or disassembling the Meat Slicer, make sure the Meat Slicer Motor is OFF and the PLUG IS REMOVED FROM THE OUTLET/POWER SOURCE!

WARNING!
SHARP BLADE

HANDLE CAREFULLY!
KEEP FINGERS AWAY FROM THE BLADE!
NEVER FEED FOOD BY HAND.
ALWAYS USE THE FOOD PUSHER!
*Always use completely assembled Meat Slicer with Food Carriage and Food Pusher.
Protective/cut-resistant Kevlar gloves are recommended whenever handling the Blade!*

WARNING! Before cleaning, assembling or disassembling the Meat Slicer, make sure the Meat Slicer Motor is OFF and the PLUG IS REMOVED FROM THE OUTLET/POWER SOURCE!

WARNING!
SHARP BLADE

HANDLE CAREFULLY!
KEEP FINGERS AWAY FROM THE BLADE!
NEVER FEED FOOD BY HAND.

ALWAYS USE THE FOOD PUSHER!

Always use completely assembled Meat Slicer with Food Carriage and Food Pusher.

Protective/cut-resistant Kevlar gloves are recommended whenever handling the Blade!

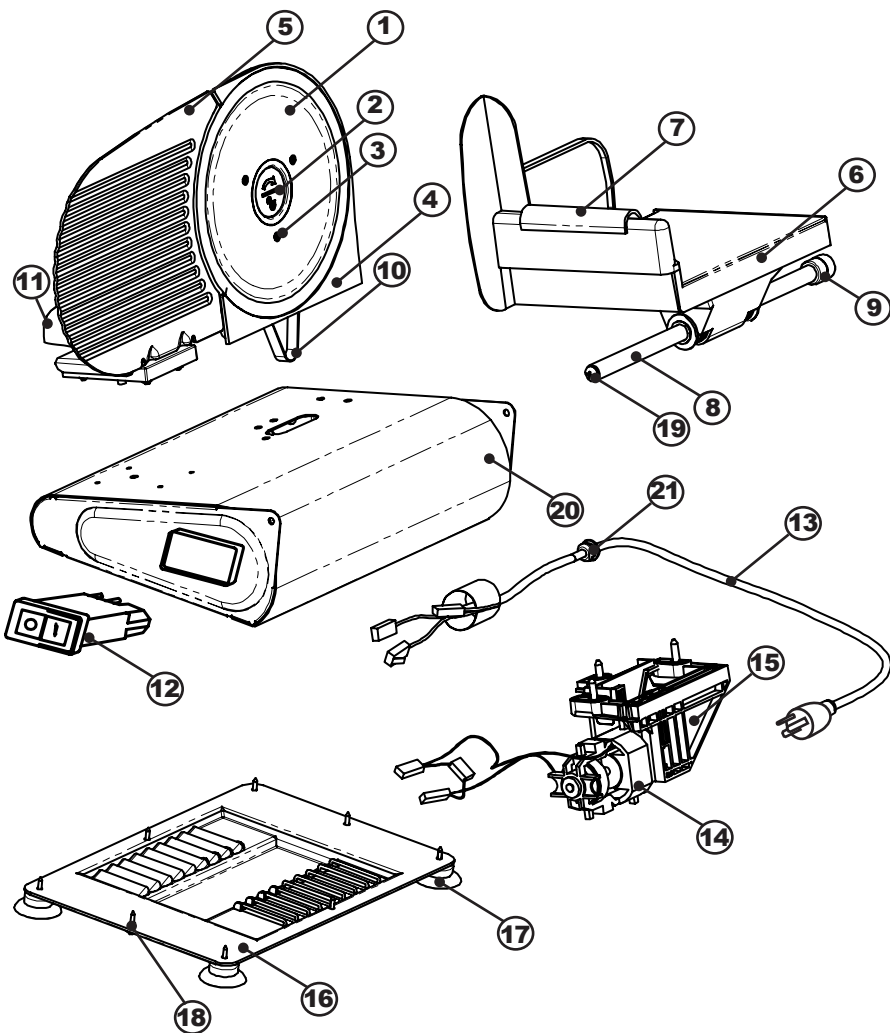

NOTE: The Meat Slicer comes with a smooth edged blade, it is not intended for slicing cheese.

WESTON WARRANTY INFORMATION

SAVE THIS WARRANTY INFORMATION FOR YOUR RECORDS!

Weston Products LLC warrants to the ORIGINAL RETAIL PURCHASER of this product that if operated in accordance with the printed instruction accompanying it, then for a period of 1 year from the date of purchase, the product shall be free from defects in material and workmanship.

The Warranty Card, along with a copy of the original receipt, must be received by Weston Products LLC within 30 days from purchase date for the warranty to apply. Failure to send the completely filled out Warranty Card, along with a copy of the original receipt, will void the warranty.

The product must be delivered to or shipped freight prepaid to Weston Products LLC for warranty services, in either its original packaging or similar packaging affording an equal degree of protection. Damage due to shipping is not the responsibility of the company. Weston Products LLC charges a \$35.00 per hour bench charge. **NOTE:** No repairs will be started without the authorization of the customer. The return shipping cost to the customer will be added to the repair invoice.

Weston Products LLC will repair (or at its discretion, replace) the product free of charge, if in the judgment of the company, it has been proven to be defective as to seller's labor and material, within the warranty period.

New or rebuilt replacements for factory defective parts will be supplied for one (1) year from the date of purchase. Replacement parts are warranted for the remainder of the original warranty period.

For non-warranty repairs, contact Weston Products LLC's Customer Service at 1-800-814-4895 M-F 8am-5pm EST (outside of the United States 440-638-3131) to obtain a Return Merchandise Authorization Number (RMA Number). Weston Products LLC will refuse all returns that do not contain this number. **DO NOT RETURN THE UNIT WITHOUT PROPER AUTHORIZATION FROM WESTON PRODUCTS LLC.**

LIMITATIONS: The warranty is void if the product is used for any purpose other than that for which it is designed. The product must not have been previously altered, repaired, or serviced by anyone else other than Weston Products LLC. If applicable, the serial number must not have been altered or removed. The product must not have been subjected to accident in transit or while in the customer's possession, misused, abused, or operated contrary to the instructions contained in the instruction manual. This includes failure caused by neglect of reasonable and necessary maintenance, improper line voltage and acts of nature. This warranty is not transferable and applies only to U.S. and Canadian sales.

Except to the extent prohibited by applicable law, no other warranties whether expressed or implied, including warranty merchantability and fitness for a particular purpose, shall apply to this product. Under no circumstances shall Weston Products LLC be liable for consequential damages sustained in connection with said product and Weston Products LLC neither assumes nor authorizes any representative or other person to assume for it any obligation or liability other than such as is expressly set forth herein. Any applicable implied warranties are also limited to the one (1) year period of the limited warranty.

This warranty covers only the product and its specific parts, not the food or other products processed in it.

CUT ALONG THE DOTTED LINE AND SEND THE WARRANTY CARD ALONG WITH A COPY OF YOUR ORIGINAL PURCHASE RECEIPT TO:

Weston Products LLC
20365 Progress Drive, Strongsville, OH 44149

WESTON WARRANTY CARD

SEND THIS CARD ALONG WITH A COPY OF YOUR ORIGINAL PURCHASE RECEIPT TO:
WESTON WARRANTY, WESTON PRODUCTS LLC, 20365 PROGRESS DRIVE, STRONGSVILLE, OH 44149

Customer Name: _____
 Address: _____
 City/State/Zip: _____
 Telephone Number: (____) _____
 E-Mail Address: _____
 Original Date of Purchase: ____/____/____
 Product Model #: _____
 Serial # (if applicable): _____



with ice. Hot cooked foods should be placed in shallow containers and immediately refrigerated so they cool rapidly. Make sure to cover foods after they are cool.

NOTE: Special considerations must be made when using venison or other wild game, since it can become heavily contaminated during field dressing. Venison is often held at temperatures that could potentially allow bacteria to grow, such as when it is being transported. Refer to the USDA Meat and Poultry Department for further questions or information on meat and food safety.

ADDITIONAL ACCESSORIES AVAILABLE

8 5/8" Slicer Replacement Blade	61-0902
44 lb Flat Top Scale	24-0302
18" x 300' Freezer Paper	83-4001-W
Freezer Tape & Dispenser	11-0201
PRO-2300 Stainless Steel Vacuum Sealer	65-0201
Multi-Pack Commercial Grade Vacuum Sealer Bags	
50 Bags	30-0107-W
Medium Kevlar Cut-Resistant Gloves	34-0102
Large Kevlar Cut-Resistant Gloves	34-0103

These products and many more products can be ordered by visiting WestonProducts.com or by calling Weston Products LLC Toll Free at 1-800-814-4895 Monday thru Friday 8:00am-5:00pm EST. Outside the U.S. call 440-638-3131

WARNING! Before cleaning, assembling or disassembling the Meat Slicer, make sure the Meat Slicer Motor is OFF and the PLUG IS REMOVED FROM THE OUTLET/POWER SOURCE!

WARNING!
SHARP BLADE

HANDLE CAREFULLY!
KEEP FINGERS AWAY FROM THE BLADE!
NEVER FEED FOOD BY HAND.
ALWAYS USE THE FOOD PUSHER!
Always use completely assembled Meat Slicer with Food Carriage and Food Pusher. Protective/cut-resistant Kevlar gloves are recommended whenever handling the Blade!

WARNING! Before cleaning, assembling or disassembling the Meat Slicer, make sure the Meat Slicer Motor is OFF and the PLUG IS REMOVED FROM THE OUTLET/POWER SOURCE!

WARNING!
SHARP BLADE

HANDLE CAREFULLY!
KEEP FINGERS AWAY FROM THE BLADE!
NEVER FEED FOOD BY HAND.
ALWAYS USE THE FOOD PUSHER!
Always use completely assembled Meat Slicer with Food Carriage and Food Pusher. Protective/cut-resistant Kevlar gloves are recommended whenever handling the Blade!

COMPONENT LIST

DIAGRAM NUMBER	PART DESCRIPTION	PART NUMBER
1	8 5/8" Stainless Steel Blade	61-0902
2	Blade Locking Screw	61-0903
3	Blade Retaining Screw (3)	61-0904
4	Blade Housing	61-0905
5	Gauge Plate	61-0906
6	Sliding Food Carriage	61-0907
7	Food Presser	61-0908
8	Sliding Shaft	61-0909
9	Sliding Shaft Spacer (2)	61-0910
10	Belt	61-0911
11	Thickness Adjustment Knob	61-0912
12	Power Switch	61-0913
13	Power Cord	61-0914
14	150 Watt Motor	61-0915
15	Motor Bracket Assembly	61-0916
16	Base Cover	61-0917
17	Suction Cup Slicer Foot (4)	61-0918
18	Base Cover and Foot Screw (8)	61-0919
19	Sliding Shaft Screw	61-0920
20	Slicer Base Housing	61-0921
21	Power Cord Strain Relief	61-0922

If any components of this unit are broken or the unit does not operate properly, call Weston Products LLC Toll Free at

1-800-814-4895

Monday thru Friday 8:00am-5:00pm EST. Outside the U.S. call 440-638-3131

GENERAL SAFETY RULES



WARNING!

READ AND FULLY UNDERSTAND ALL INSTRUCTIONS AND WARNINGS PRIOR TO USING THIS UNIT. YOUR SAFETY IS MOST IMPORTANT! FAILURE TO COMPLY WITH PROCEDURES AND SAFE GUARDS MAY RESULT IN SERIOUS INJURY OR PROPERTY DAMAGE. REMEMBER: YOUR PERSONAL SAFETY IS YOUR RESPONSIBILITY!

- CAUTION! THE BLADE IS EXTREMELY SHARP.** Handle the **Blade** carefully when cleaning, removing and inserting. **DO NOT TOUCH THE SHARP EDGE OF THE BLADE.** It is recommended that cut-proof Kevlar gloves be worn when handling the blade. **NEVER TOUCH THE BLADE WHEN THE SLICER IS IN USE.**
- Be careful, the **Blade** continues to spin after the **Slicer** has been turned off. Wait for the **Blade** to stop. **NEVER TRY TO STOP THE BLADE** in any way whatsoever. **DO NOT** touch moving parts. Personal injury may result.
- Remove the **Blade** periodically to clean behind. Clean with hot soapy water. Carefully wipe **Blade** with rubbing alcohol and allow to dry.
- Periodically inspect the **Blade** diameter. **DO NOT USE THE SLICER IF THE DIAMETER OF THE BLADE HAS DECREASED BY 3/8" (0.95 cm).** Replace the **Blade** if necessary.
- DO NOT** use the **Meat Slicer** without the **Food Presser** and the **Food Carriage** secured into place.
- ALWAYS DISCONNECT Meat Slicer** from power source before servicing, changing accessories, when the **Meat Slicer** is not in use or cleaning the unit.
- Plug the **Meat Slicer** into a standard 120 Volt, 60 Hz wall outlet.
- DO NOT** use the **Meat Slicer** if the **Power Cord, Plug** or any other parts are damaged. **DO NOT** use with a damaged cord or plug or after the appliance malfunctions or is dropped or damaged in any manner. If the **Meat Slicer** is damaged, call Customer Service to return the **Meat Slicer** for examination, repair or electrical or mechanical adjustment. **DO NOT ATTEMPT TO REPLACE THE CORD.** Be sure to not allow the **Power Cord** to drape into your work area or onto hot surfaces. Check that all parts are operating properly, and perform the intended functions. Check for alignment of moving parts or any other conditions that may affect the operation.
- NEVER** use any accessories or parts from other manufacturers. Doing so will **VOID YOUR WARRANTY** and may cause fire, electrical shock or injury.
- TO PROTECT AGAINST RISK OF ELECTRICAL SHOCK: DO NOT SUBMERGE THE Meat Slicer INTO WATER OR LIQUID. BE SURE THE Meat Slicer IS DISCONNECTED FROM THE POWER SOURCE BEFORE CLEANING.** Wash all parts by hand and thoroughly dry. Thoroughly clean all parts that will come in contact with food before using the appliance. **NEVER** rinse appliance **Meat Slicer** under tap, only use a moist cloth to clean the **Meat Slicer Motor Unit**.
- Reduce risk of unintentional starting. Make sure the **Power Switch** is in the "OFF" position before attaching to the power source.
- KEEP FINGERS CLEAR** of the **Blade AT ALL TIMES. NEVER REACH INTO THE Blade**, doing so may cause serious injury. **ALWAYS USE THE PROVIDED FOOD PRESSER, NEVER FEED FOOD BY HAND.**
- NEVER** use fingers to scrape food away from the **Blade** while the **Meat Slicer** is in operation. **NEVER** feed the food into the **Meat Slicer** by hand. **SEVERE INJURY MAY RESULT.**
- NEVER LEAVE THE Meat Slicer UNATTENDED.** Be safe, **DISCONNECT** the **Meat Slicer** from power source before leaving the work area or when the **Meat Slicer** is not in use. Close supervision is necessary when any appliance is used near children. This appliance is **NOT** to be used by children.
- Wait until all moving parts have stopped before you remove any part of the **Meat Slicer**.
- TIE BACK** loose hair and clothing, and roll up long sleeves before operating the **Meat Slicer**. **REMOVE** ties, rings, watches, bracelets, or other jewelry before operating the **Meat Slicer**.
- Be sure the **Meat Slicer** is on a stable work surface. Be sure all the **Meat Slicer Feet** are stable.
- Operate the **Meat Slicer** only when the **Blade Locking Screw** is properly engaged and tightened. To avoid danger or injury, only use the **Meat Slicer** when fully assembled.
- DO NOT** attempt to slice fish, boned meats, frozen or other hard items.
- WEAR EYE PROTECTION.** Wear safety glasses. Everyday eye glasses are not safety glasses. Safety glasses conform to ANSI Z87.1 requirements. Note: approved safety glasses have Z87 printed or stamped on them.
- DO NOT** use outdoors.
- DO NOT** use the **Meat Slicer** while under the influence of drugs, medications or alcohol.
- DO NOT** let the **Power Cord** hang over edge of work surface.
- DO NOT** attempt to operate the **Meat Slicer** if the **Meat Slicer** itself is cold. The **Meat Slicer** temperature should be at least 45°F (7°C) before beginning.
- The manufacturer declines any responsibility in the case of improper use of this machine.

SAVE THESE INSTRUCTIONS!

Refer to them often and use them to instruct others.

FOOD SAFETY

There are basic rules to follow when handling food. They are **COOK, SEPARATE, CLEAN,** and **CHILL.**

COOK

It's crucial to cook food to a safe internal temperature to destroy bacteria that is present. The safety of hamburgers and other foods made with ground meat has been receiving a lot of attention lately, and with good reason. When meat is ground, the bacteria present on the surface is mixed throughout the ground mixture. If this ground meat is not cooked to at least 160°F to 165°F (71°C to 74°C), bacteria will not be destroyed and there's a good chance you will get sick.

Solid pieces of meat like steaks and chops don't have dangerous bacteria like E. coli on the inside, so they can be served more rare. Still, any beef cut should be cooked to an internal temperature of at least 145°F (63°C) (medium rare). The safe temperature for poultry is 180°F (82°C) and solid cuts of pork should be cooked to 160°F (71°C). Eggs should be thoroughly cooked too. If you are making a meringue or other recipe that uses uncooked eggs, buy specially pasteurized eggs or use prepared meringue powder.

SEPARATE

Foods that will be eaten uncooked and foods that will be cooked before eating **MUST ALWAYS** be separated. Cross-contamination occurs when raw meats or eggs come in contact with foods that will be eaten uncooked. This is a major source of food poisoning. Always double-wrap raw meats and place them on the lowest shelf in the refrigerator so there is no way juices can drip onto fresh produce. Then use the raw meats within 1-2 days of purchase, or freeze for longer storage. Defrost frozen meats in the refrigerator, not on the counter.

When grilling or cooking raw meats or fish, make sure to place the cooked meat on a clean platter. Don't use the same platter you used to carry the food out to the grill. Wash the utensils used in grilling after the food is turned for the last time on the grill, as well as spatulas and spoons used for stir-frying or turning meat as it cooks.

Make sure to wash your hands after handling raw meats or raw eggs. Washing hands with soap and water, or using a pre-moistened antibacterial towelette is absolutely necessary after you have touched raw meat or raw eggs. Not washing hands and surfaces while cooking is a major cause of cross-contamination.

CLEAN

Wash your hands and work surfaces frequently when you are cooking. Washing with soap and warm water for at least 15 seconds, then dry with a paper towel.

CHILL

Chilling food is very important. The danger zone where bacteria multiply is between 40°F and 140°F (4°C and 6°C). Your refrigerator should be set to 40°F (4°C) or below; your freezer should be 0°F (-17°C) or below. Simple rule: serve hot foods hot, cold foods cold. Use chafing dishes or hot plates to keep food hot while serving. Use ice water baths to keep cold foods cold. Never let any food sit at room temperature for more than 2 hours - 1 hour if the ambient temperature is 90°F (32°C) or above. When packing for a picnic, make sure the foods are already chilled when they go into the insulated hamper. The hamper won't chill food - it just keeps food cold when properly packed

CLEANING INSTRUCTIONS

WARNING! Before cleaning, assembling or disassembling the Meat Slicer, make sure the Meat Slicer Motor is OFF and the PLUG IS REMOVED FROM THE OUTLET/POWER SOURCE!

WARNING!
SHARP BLADE

HANDLE CAREFULLY!
KEEP FINGERS AWAY FROM THE BLADE!
NEVER FEED FOOD BY HAND.
ALWAYS USE THE FOOD PUSHER!
Always use completely assembled Meat Slicer with Food Carriage and Food Pusher.
Protective/cut-resistant Kevlar gloves are recommended whenever handling the Blade!

1. ALWAYS disconnect the appliance from the power source before cleaning.
2. Never immerse the **Motor Assembly** of this appliance in water or other liquid.
3. The **Blade**, **Food Presser**, and **Food Tray** can all be hand washed in hot soapy water. Because these parts come in contact with food, they should be sanitized by being dipped in a solution of 2 ounces (0.06 L) of unscented non-chlorine bleach mixed with 5 gallons (19 L) of water. Allow sanitized parts to air dry. Do not use harsh abrasives to clean any part of the **Meat Slicer**. **Use extreme caution when handling or cleaning the Blade, as it is extremely sharp! Do not leave Blade underwater; trying to handle sharp objects in water can be hazardous. It is highly recommended to wear cut-resistant Kevlar Gloves when removing, cleaning and re-installing the Blade.**
4. Set the **Thickness Adjustment Knob** to "0".
5. Remove **Food Presser** and rotate the **Sliding Food Carriage** out of the way in order to allow for easy access to the **Blade**.
6. To remove the **Blade** hold the **Blade** with one hand and use a coin to unlock the **Blade Locking Screw** by turning it clockwise *Figure 6*. Carefully pull the **Blade** off and hold it by using the hole in the center of the **Blade**.
7. Clean the outer surface of the **Meat Slicer Body & Base** with a damp cloth. Mild detergent or water can be used to dampen the cloth. Wipe away from the **Blade**, NEVER wipe toward the **Blade**. Never immerse **Motor Assembly** in water or any other liquid. Do not use steel wool, abrasive cleaners, or sharp utensils to clean.
8. To allow for easier cleaning, the **Thickness Adjustment Knob** can be turned past "0" to allow the **Gauge Plate** to slide back. **NOTE:** Use this feature only with **Blade** removed. (After cleaning and before reassembly, reset the **Thickness Adjustment Knob** to "0".)

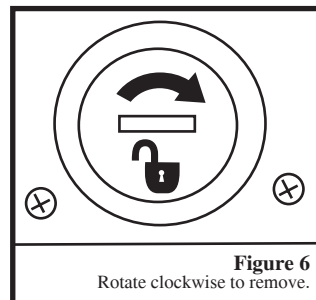

9. After cleaning and drying, install the **Blade** and **Blade Screw** to the **Motor Assembly** in reverse order of step 6. Make sure the **Blade Locking Screw** is properly engaged and tightened. Rotate the **Sliding Food Carriage** back to its proper position and re-install the **Food Presser**.

WARNING! Before cleaning, assembling or disassembling the Meat Slicer, make sure the Meat Slicer Motor is OFF and the PLUG IS REMOVED FROM THE OUTLET/POWER SOURCE!

WARNING!
SHARP BLADE

HANDLE CAREFULLY!
KEEP FINGERS AWAY FROM THE BLADE!
NEVER FEED FOOD BY HAND.
ALWAYS USE THE FOOD PUSHER!
Always use completely assembled Meat Slicer with Food Carriage and Food Pusher.
Protective/cut-resistant Kevlar gloves are recommended whenever handling the Blade!

GROUNDING INSTRUCTIONS

GROUNDING

This appliance must be grounded while in use to protect the operator from electrical shock. The appliance is equipped with a 3-conductor cord and a 3-prong grounding type plug to fit the proper grounding-type receptacle. The appliance has a plug that looks like *Figure A*. An adaptor, *Figure B*, should be used for connecting *Figure A* plugs to two-prong receptacles. The grounding tab which extends from the adaptor must be connected to a permanent ground such as a properly grounded outlet box as shown in *Figure C* using a metal screw.

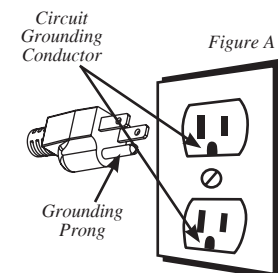

EXTENSION CORDS

Use only 3-wire extension cords which have 3-prong grounding-type plugs and a 3-pole cord connector that accepts the plug from the appliance. Use only extension cords having an electrical rating not less than the rating of the appliance. DO NOT use damaged extension cords. Examine extension cord before using and replace if damaged. DO NOT abuse extension cord and do not yank on any cord to disconnect. Keep cord away from heat and sharp edges.

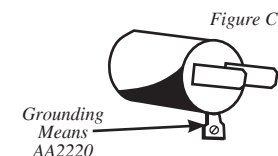
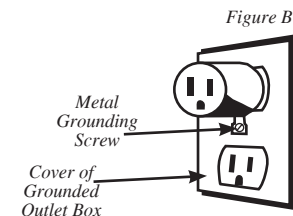

PRIOR TO USE

Before using your **Meat Slicer** for the first time, wash all parts thoroughly, taking particular care to remove all grease and oil from surfaces. Dry all parts thoroughly before reassembling. See "Cleaning Instructions" section of this booklet.

Carefully remove the black protective shield from the **Meat Slicer Blade** *Figure 1*. **CAUTION!** This exposes the **Sharp Blade!**

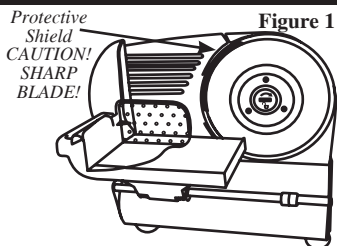

DIRECTIONS FOR USE

WARNING! Before cleaning, assembling or disassembling the Meat Slicer, make sure the Meat Slicer Motor is OFF and the PLUG IS REMOVED FROM THE OUTLET/POWER SOURCE!

WARNING!
SHARP BLADE

HANDLE CAREFULLY!
KEEP FINGERS AWAY FROM THE BLADE!
NEVER FEED FOOD BY HAND.
ALWAYS USE THE FOOD PUSHER!
Always use completely assembled Meat Slicer with Food Carriage and Food Pusher.
Protective/cut-resistant Kevlar gloves are recommended whenever handling the Blade!

1. Make sure the **Blade Locking Screw** is properly engaged and tightened *Figure 2*.

2. Place the **Meat Slicer** on a flat stable surface. Be sure the **Meat Slicer** is in the "OFF" position. Plug the appliance into a properly rated electrical outlet (120V AC, 60Hz).

3. Place a tray or plate behind the **Meat Slicer** and below the **Blade** to collect the sliced food as it exits the **Blade** area.

4. Place food on to the **Sliding Food Carriage** between the **Gauge Plate** and the **Food Presser**. To avoid danger of injury, ALWAYS use the **Food Carriage** and **Food Presser** while slicing *Figure 3*.

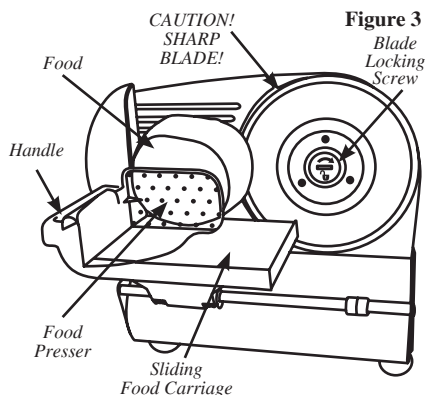

5. Rotate the **Thickness Adjustment Knob** to set the **Gauge Plate** to the desired cutting thickness *Figure 4*.

6. Start the **Meat Slicer** by depressing the green "ON" button on the **Power Switch**.

7. Hold the **Food Presser** and **Sliding Food Carriage Handle**; keep your hands protected behind the **Food Presser**.

8. To begin slicing, push food in toward the **Gauge Plate** with the **Food Presser** and slide food over with the **Sliding Food Carriage** until it reaches the end of its travel. Slide the **Sliding Food Carriage** back and repeat until you have sliced the desired amount of food.

9. When finished, depress the red "OFF" button on the **Power Switch** to turn off the **Meat Slicer**.

10. For safety, always return the **Thickness Adjustment Knob** to "0" after use to properly shield the sharp edge of **Blade**.

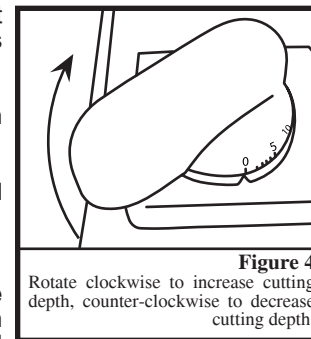

Figure 4
Rotate clockwise to increase cutting depth, counter-clockwise to decrease cutting depth.

NOTE: DO NOT OPERATE THE APPLIANCE CONTINUOUSLY FOR MORE THAN 15 MINUTES. Be sure to allow the appliance to cool down for 30-60 minutes before operating again. Failure to allow the slicer motor to cool down may result in damage to the motor.

WARNING! Before cleaning, assembling or disassembling the Meat Slicer, make sure the Meat Slicer Motor is OFF and the PLUG IS REMOVED FROM THE OUTLET/POWER SOURCE!

WARNING!
SHARP BLADE

HANDLE CAREFULLY!
KEEP FINGERS AWAY FROM THE BLADE!
NEVER FEED FOOD BY HAND.
ALWAYS USE THE FOOD PUSHER!
Always use completely assembled Meat Slicer with Food Carriage and Food Pusher.
Protective/cut-resistant Kevlar gloves are recommended whenever handling the Blade!