

PARTS LIST

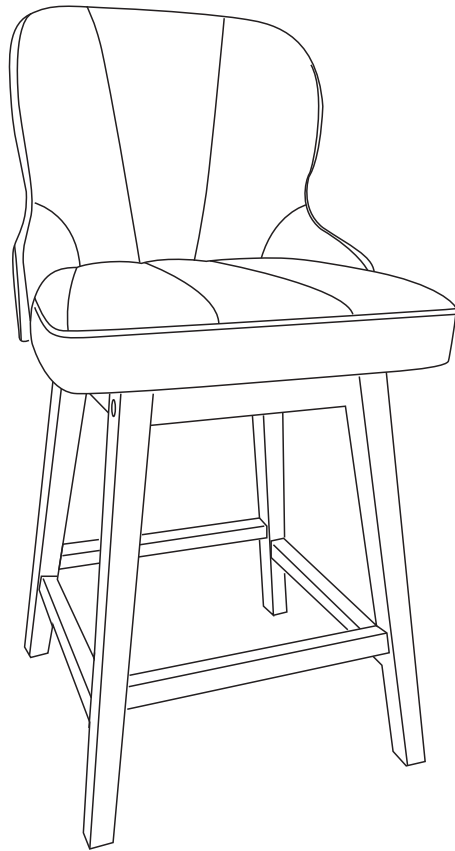

A*1

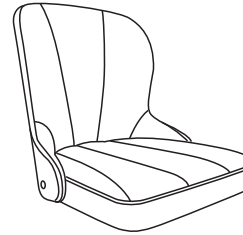

B*2

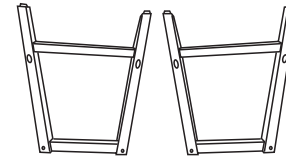

C*2

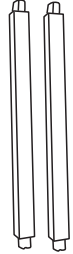

D*1

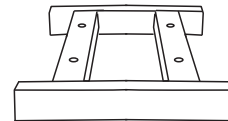

E*1

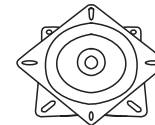

NOTE:

This brochure contains IMPORTANT safety info. Please read and keep for future reference.



Weight Limitation

250LBS

HARDWARE LIST

F*4



G*4



H*4



I*4



J*4



K*8



L*1



M*1



ASSEMBLY INSTRUCTIONS

STEP:1

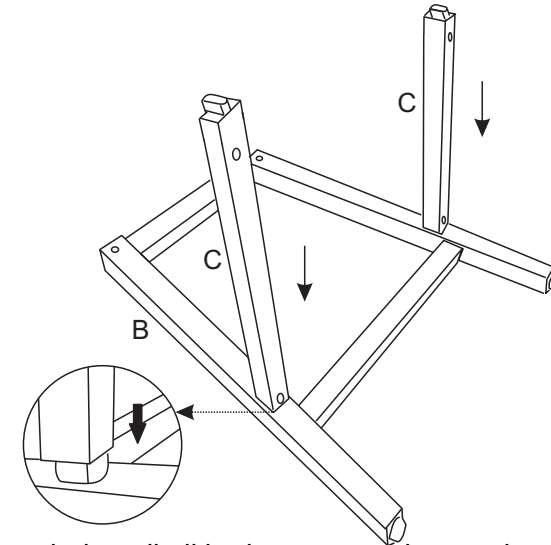

Don't fasten any bolt until all bolts connected properly and position aligned correctly.

STEP:2

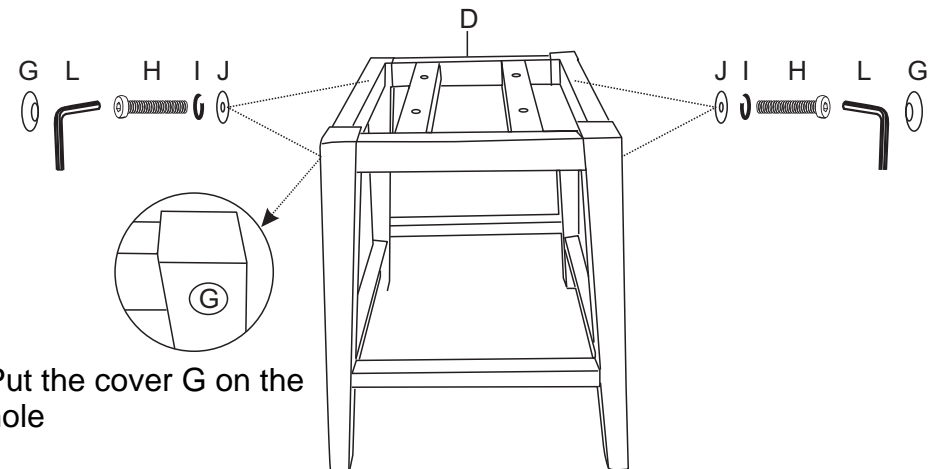

Put the cover G on the hole

Don't fasten any bolt until all bolts connected properly and position aligned correctly.

STEP:3

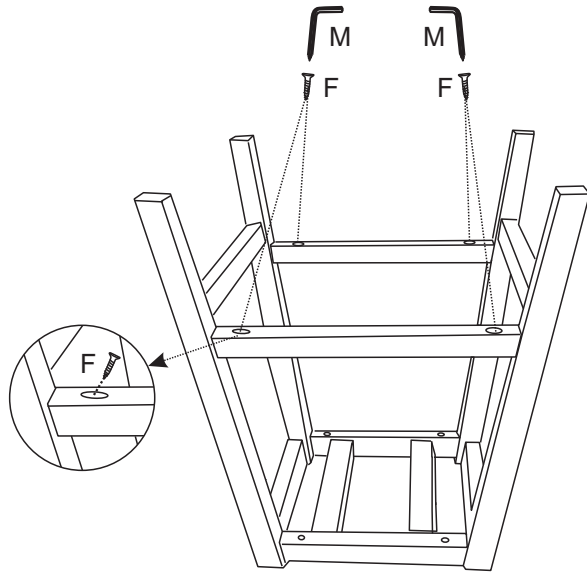

STEP:5

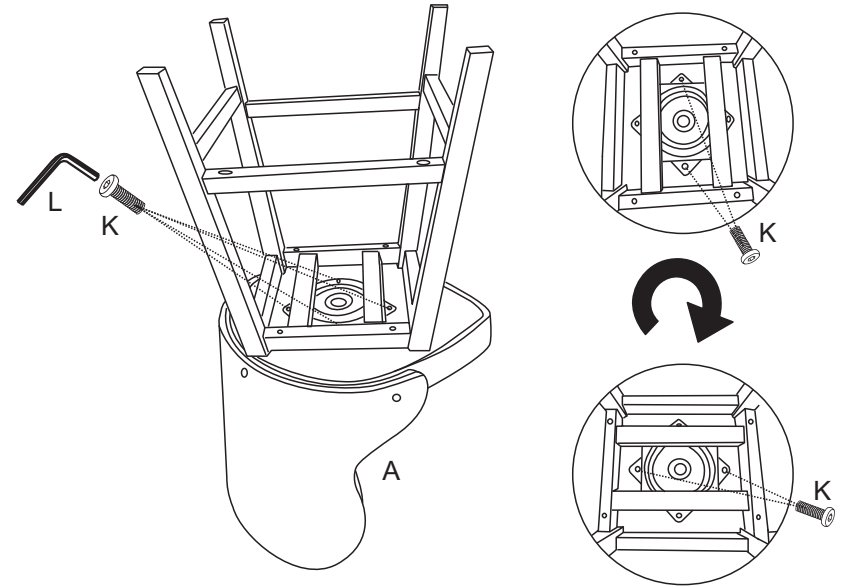

pls turn the hole of mechanism to big space and screw slowly

STEP:4

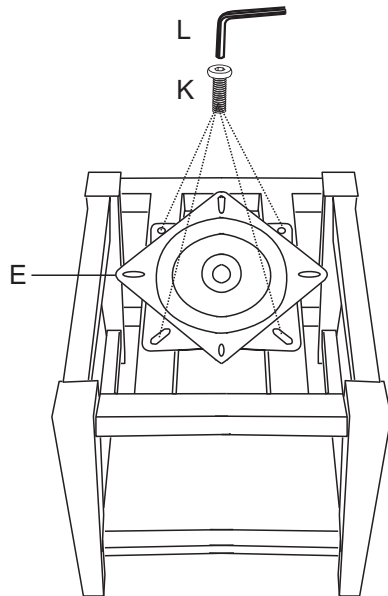

Pls turn E to be 90 degrees

STEP: 6

