



# INSPIREDHOME®

## NST153-09 Assembly Instructions

Araceli

### Parts

| NO. | Picture | Description | Size(cm)           | QTY |
|-----|---------|-------------|--------------------|-----|
| 1   |         | Table Body  | 47.6x39.3<br>x49.8 | 1   |
| 2   |         | Table Leg   | 15x8.4x8.4         | 4   |

### STEP:1

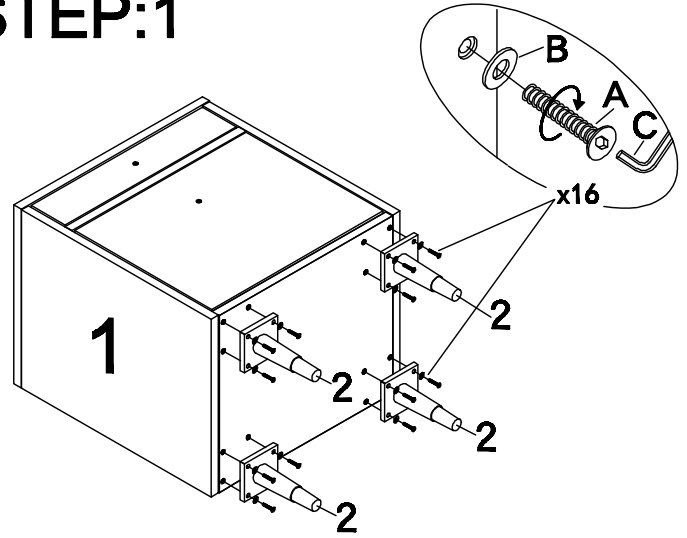

### Hardware

| NO. | Picture | Description | Size(mm) | QTY |
|-----|---------|-------------|----------|-----|
| A   |         | Bolt        | M6x25    | 16  |
| B   |         | Washer      | M6x18    | 16  |
| C   |         | Allen Key   | M4       | 1   |

### STEP:2

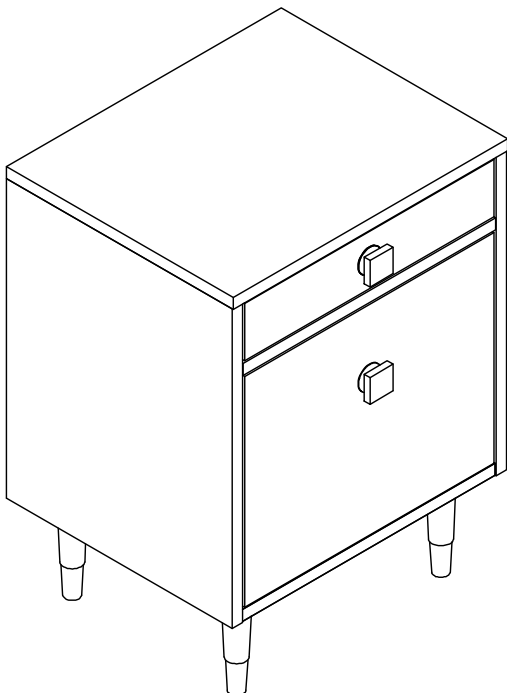
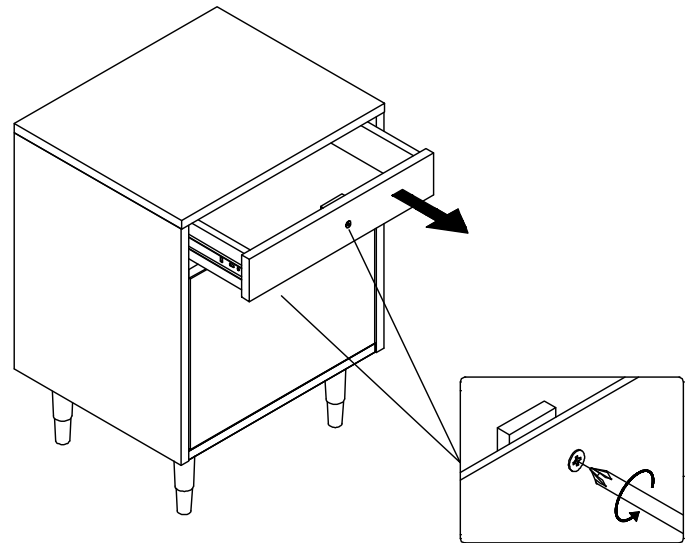

### STEP:3

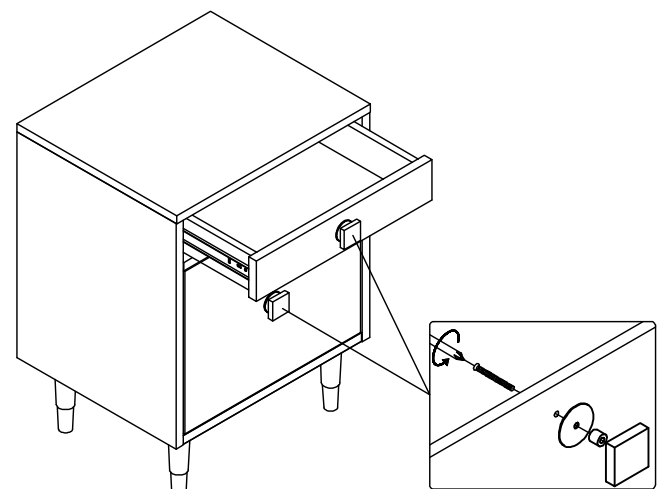

Overall Size:18.8"x15.5"x25.5"H