









Thank you for purchasing this quality product. Be sure to check all packing materials carefully for small parts, which may have come loose inside the carton during shipment. Identify and count all items and compare with the parts list and/or hardware list shown below.

PARTS LIST			
No.	DESCRIPTION	SKETCH	Q'TY
A	CHAIRBACK		2
B	CUSHION SEAT		2
C	FRONT LEG		4

HARDWARE LIST			
No.	DESCRIPTION	SKETCH	Q'TY
1	Long Bolt (1/4" x 3-1/4")		8
2	Medium Bolt (1/4" x 2-1/4")		8
3	Short Bolt (1/4" x 1-3/4")		6
4	Spring Washer (1/4 ")		22
5	Flat Washer (1/4 ")		22
6	Allen key M4		2

### DO NOT TIGHTEN LEGS UNTIL THE CHAIR IS FULLY ASSEMBLED

**STEP 1:** Assemble the cushion seat (B) with the back legs of the chairback (A) by using Allen Key (6) with hardware 3, 4, and 5.

**\*\*Attention: DO NOT TIGHTEN THE BOLTS.**

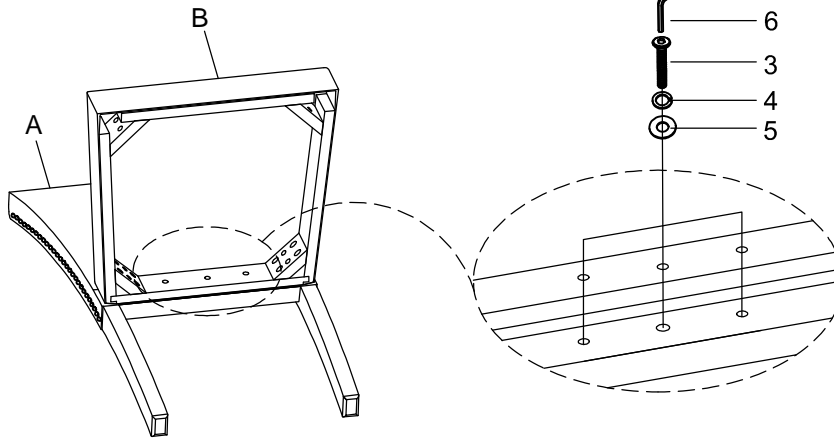

**STEP 2:** Place the chairback (A) on a soft and clean surface. Assemble the cushion seat (B) with the chairback (A) by using Allen Key (6) with hardware 1, 4, and 5.

**\*\*Attention: DO NOT TIGHTEN THE BOLTS.**

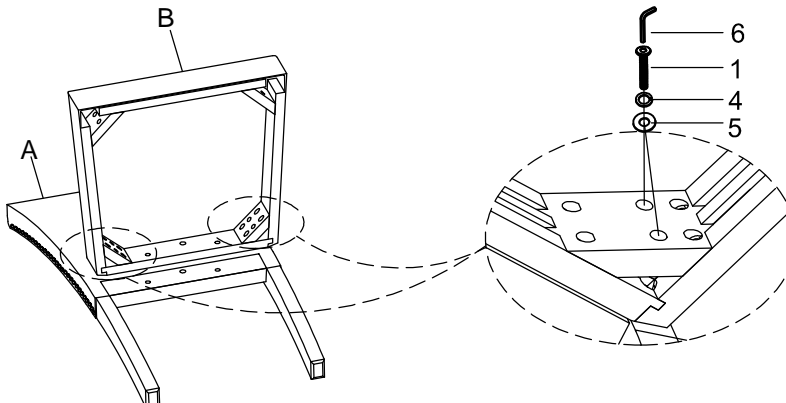

STEP 3: Assemble the front legs (C) with the Cushion Seat (B) by using Allen Key (6) with hardware 2, 4, and 5.

\*\*Attention: DO NOT TIGHTEN THE BOLTS

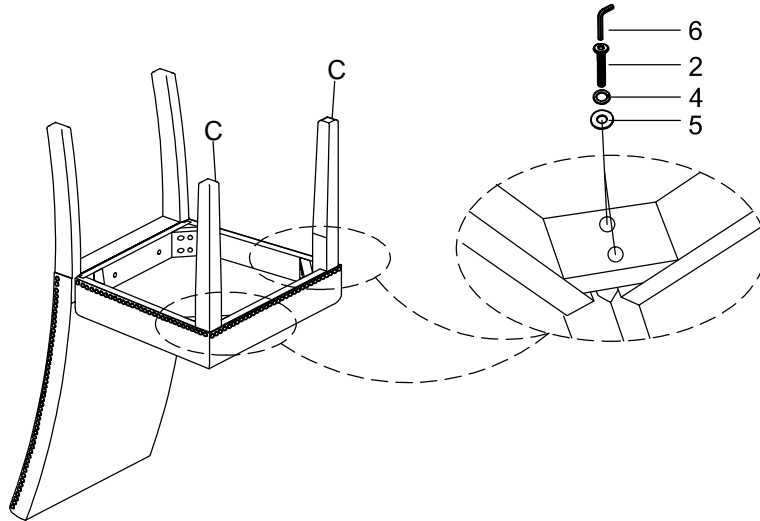

STEP 4: To level the chair, stand the chair up on a flat surface and tighten all the bolts by using Allen Key (6).

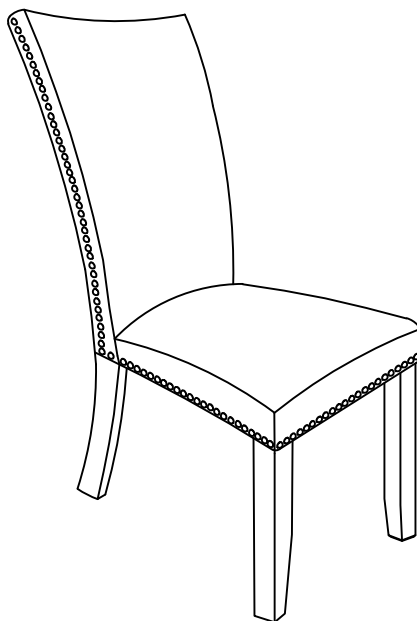



Assembly Instruction

**LYRA DINING TABLE**

D3765-10B LYRA PEDESTAL BASE

D3765-10T LYRA DINING TABLE TOP AND BASE BOTTOM

PARTS LIST				HARDWARE LIST			
No.	DESCRIPTION	SKETCH	Q'TY	No.	DESCRIPTION	SKETCH	Q'TY
A	TABLE TOP		1	1	ALLEN BOLT (5/16" x2-1/2")		3
B	LEFT SIDE FACING (LSF) TABLE LEG		1	2	ALLEN BOLT (5/16" x1-3/8")		20
C	RIGHT SIDE FACING (RSF) TABLE LEG		1	3	SPRING WASHER (5/16 ")		23
D	TABLE BASE		1	4	FLAT WASHER (5/16 ")		23
E	TABLE TOP CONNECTION PLATE		2	5	SCREW M4*1"		2
F	TABLE LEG CONNECTION WRAP		1	6	ALLEN KEY M5		1

**STEP 1:** Place the TABLE LEGS (B & C) upside down on a soft and clean surface. Assemble the LSF TABLE LEG (B) and the RSF TABLE LEG (C) by using ALLEN KEY (6) with hardware 1, 3, and 4.

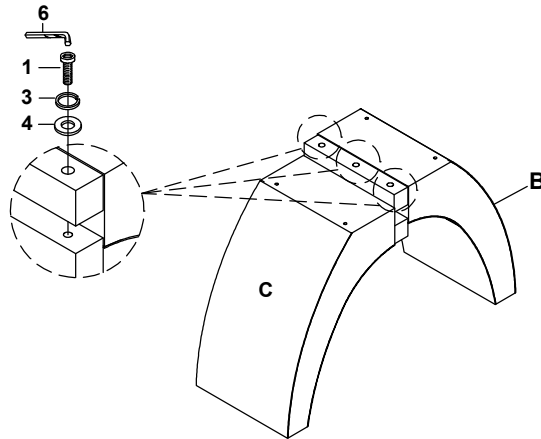

**STEP 2:** Assemble the TABLE LEG CONNECTION WRAP (F) to the center of the TABLE LEGS (B & C) by using a screwdriver with hardware 5.

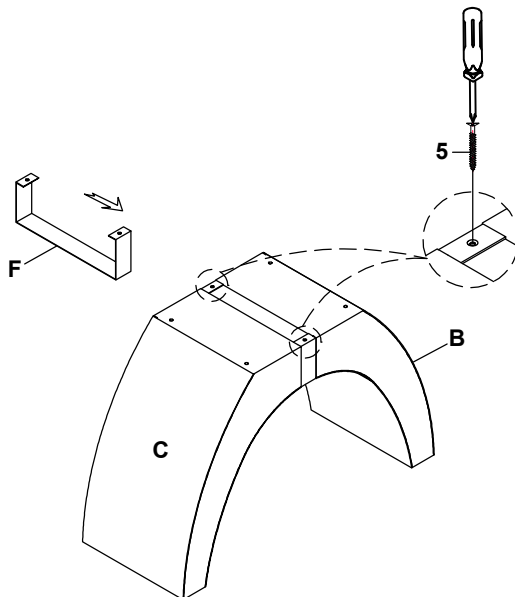

MADE IN VIETNAM

STEP 3: Turn the assembled bottom piece right side up. Assemble the TABLE TOP CONNECTON PLATE (E) to the TABLE LEGS (B & C) by using ALLEN KEY (6) with hardware 2, 3, and 4.

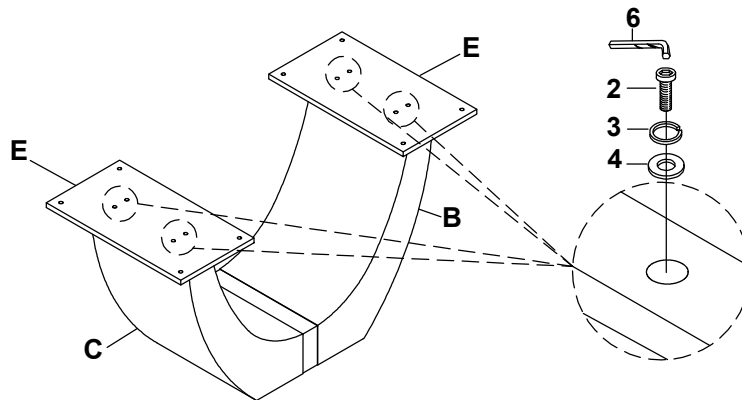

STEP 4: Turn the assembled bottom piece upside down. Assemble the TABLE BASE (D) by using ALLEN KEY (6) with hardware 2, 3, and 4.

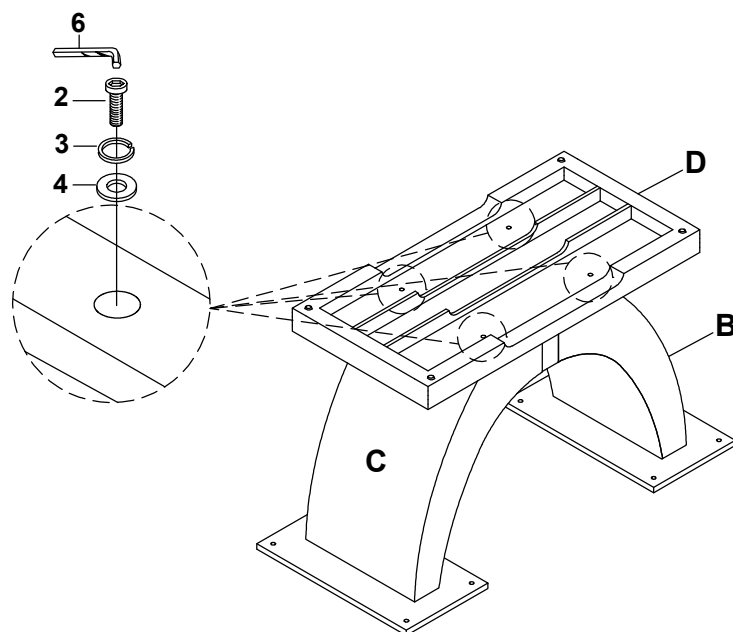

STEP 5: Assemble the bottom piece with the TABLE TOP (A) by using ALLEN KEY (6) with hardware 2, 3, and 4.

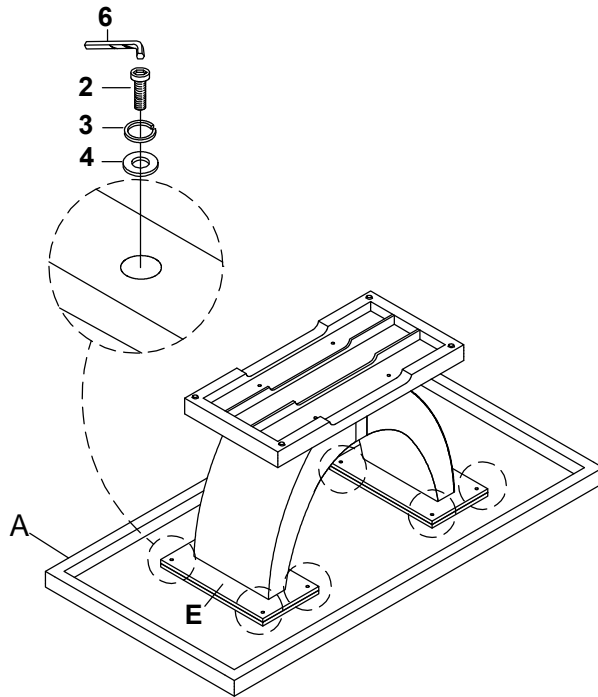

STEP 6: To level the table, place the table right side up on a flat surface and adjust the levelers.

