

# ASSEMBLY INSTRUCTIONS

## COVENTRY HALL COLLECTION



MODEL : B1828-050 COVENTRY HALL DRESSER  
(1 Per Carton)

Thank you for purchasing this quality product. Be sure to check all packing materials carefully for small parts, which may have come loose inside the carton during shipment. Identify and count all items and compare with the parts list and/or hardware list shown below.

Please read all instructions carefully. See the hardware and furniture part listing for guidance. Be sure you have all parts listed before beginning assembly. Place all wooden parts on a clean, flat surface to protect the finish from scratches. Follow the diagram to assemble.

### CAUTION

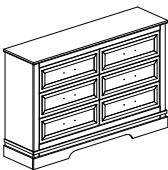
1. Do not fully tighten the nuts or bolts until the table is fully assembled.
2. Please tighten by hand, not by a drill. Overtightening will damage threads. Do not overtighten.
3. Keep all hardware out of the reach of children.

PARTS LIST				HARDWARE LIST			
ITEM	DESCRIPTION	SKETCH	QTY	ITEM	DESCRIPTION	SKETCH	QTY
A	DRESSER		1 PC	1	TIPPING RESTRAINT		1 PC

### HARDWARE DIMENSIONS VERIFICATION TOOL

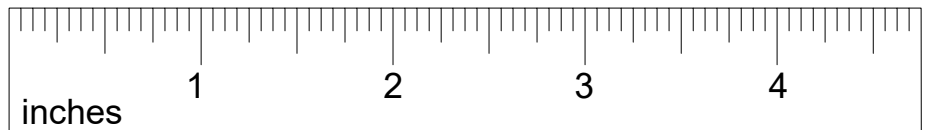

**STEP 1:** Install the handle by unscrewing the bolts with a screwdriver and move the handle to the outside of the drawers and screw the bolts back in from the inside of the drawers.

Repeat for each handle.

**\*\* Attention: DO NOT OVER TIGHTEN THE SCREWS.**

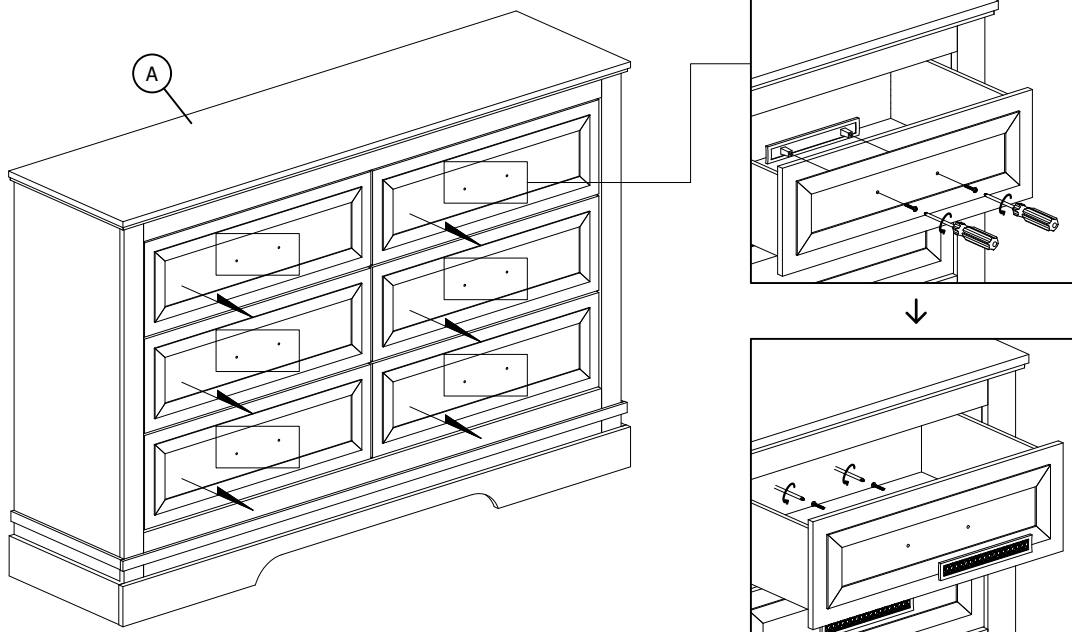

# ASSEMBLY INSTRUCTIONS

## COVENTRY HALL COLLECTION

MODEL : B1828-050 COVENTRY HALL DRESSER  
(1 Per Carton)

**STEP 2:** Follow the instructions from the anti-tipping kit to install the Tipping Restraint (1).

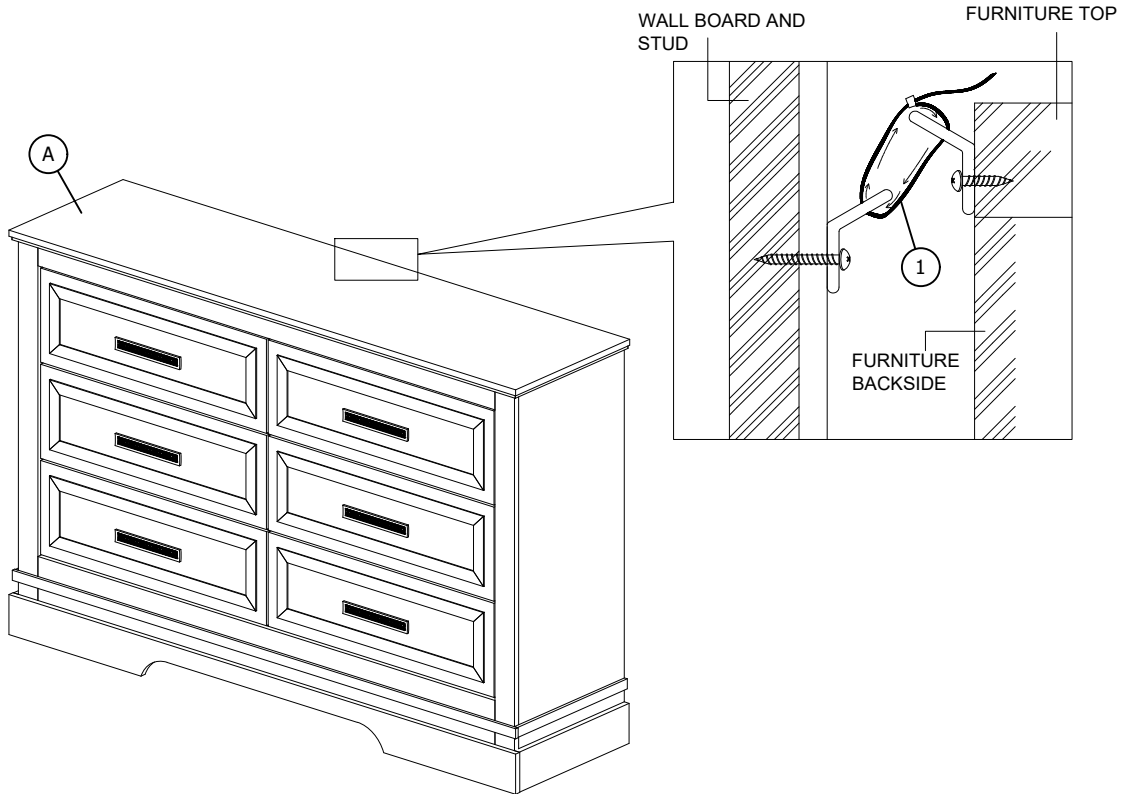

**ASSEMBLY COMPLETED**

# ASSEMBLY INSTRUCTIONS

## COVENTRY HALL COLLECTION







MODEL : B1828-060 COVENTRY HALL MIRROR  
(1 Per Carton)

Thank you for purchasing this quality product. Be sure to check all packing materials carefully for small parts, which may have come loose inside the carton during shipment. Identify and count all items and compare with the parts list and/or hardware list shown below.

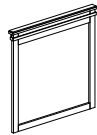
Please read all instructions carefully. See the hardware and furniture part listing for guidance. Be sure you have all parts listed before beginning assembly. Place all wooden parts on a clean, flat surface to protect the finish from scratches. Follow the diagram to assemble.

**CAUTION**

1. Do not fully tighten the nuts or bolts until the table is fully assembled.
2. Please tighten by hand, not by a drill. Overtightening will damage threads. Do not overtighten.
3. Keep all hardware out of the reach of children.

PARTS LIST				HARDWARE LIST			
ITEM	DESCRIPTION	SKETCH	QTY	ITEM	DESCRIPTION	SKETCH	QTY
A	MIRROR		1 PC	1	BOLT M6 x 1 9/16"		8 PCS
B	MIRROR SUPPORT		2 PCS	2	SPRING WASHER M6 x 1/2"		8 PCS
C	DRESSER (FROM DRESSER BOX)		1 PC	3	FLAT WASHER M6 x 3/4"		8 PCS
				4	ALLEN KEY M4 x 2 3/8"		1 PC

**HARDWARE DIMENSIONS  
VERIFICATION TOOL**



**STEP 1:** Assemble the Mirror Support (B) with the Dresser (C) by using Allen Key (4) with hardware (1), (2) and (3).  
\*\* Attention: DO NOT OVER TIGHTEN THE BOLTS.

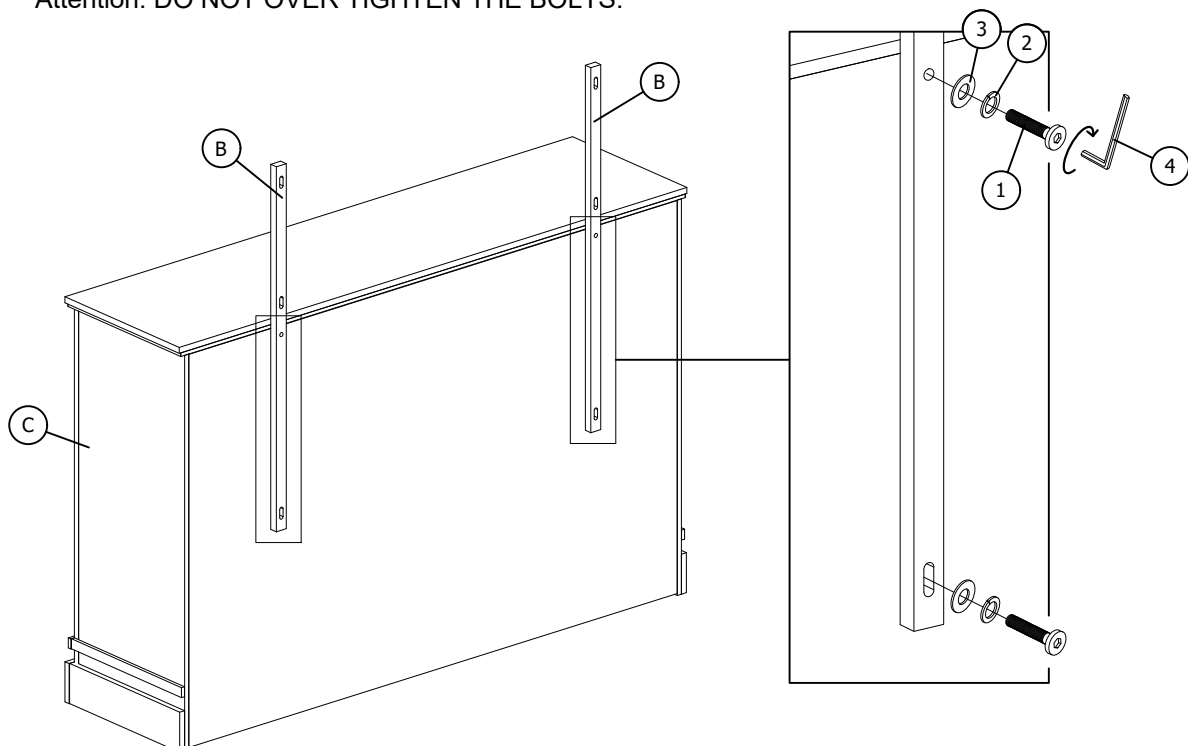

# ASSEMBLY INSTRUCTIONS

## COVENTRY HALL COLLECTION

MODEL : B1828-060 COVENTRY HALL MIRROR  
(1 Per Carton)

**STEP 2:** Assemble the Mirror (A) with the Mirror Support (B) by using Allen Key (4) with hardware (1), (2) and (3).  
**\*\* Attention: DO NOT OVER TIGHTEN THE BOLTS.**

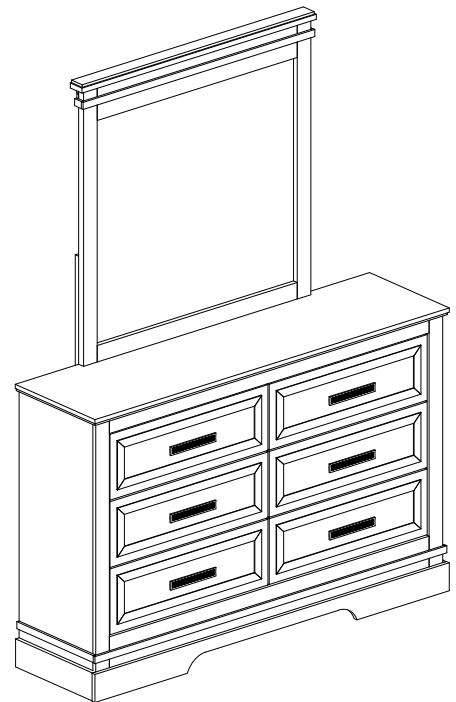
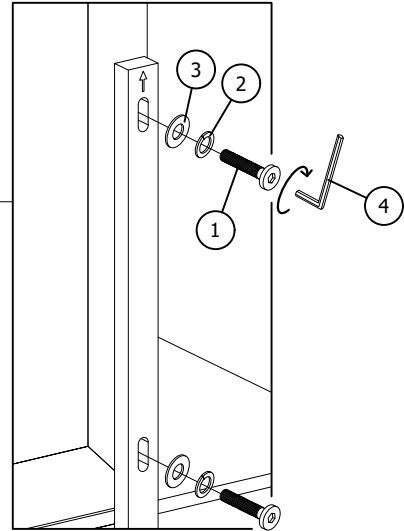
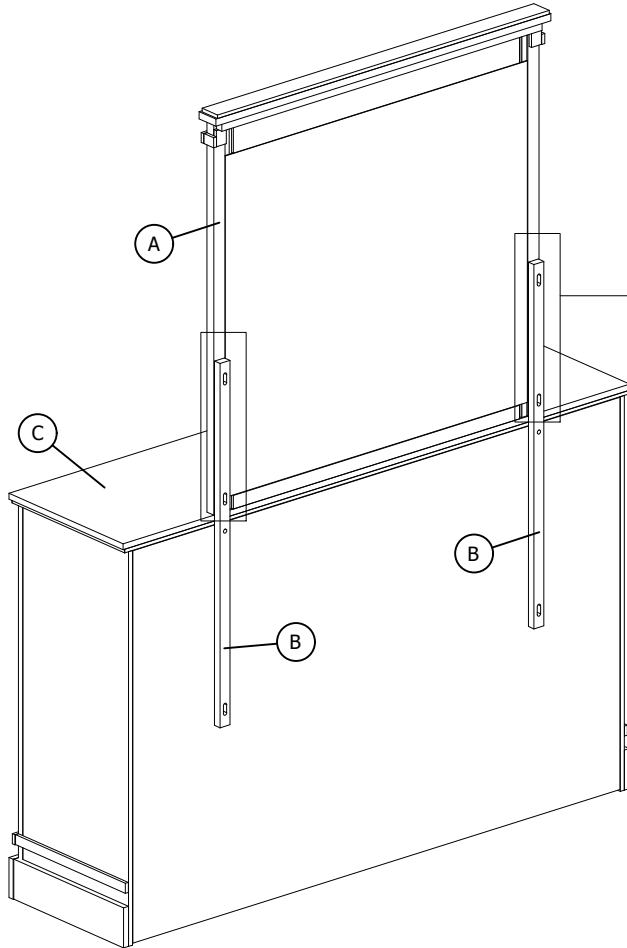

**ASSEMBLY COMPLETED**