

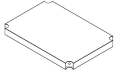

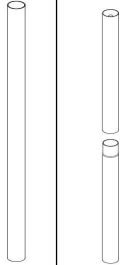

## PACKING LIST

Item	Part Name	QTY	Picture
1	Panel	1 PCS	
2	Shelves	2 PCS	
3	Table legs ( whole / separated) Tip: legs various to refer the Product Parameters table	4 PCS (4PCS/4PCS)	
4	Support feet Tip: various to refer the Product Parameters table	4 PCS	 <b>(pre-installed)</b>
5	M6 Allen socket screws	12PCS	
6	Φ6 gasket	12PCS	
7	hex key	1PCS	
8	User Manual	1PCS	

## ASSEMBLY STEP

This is the original instruction, please read all manual instructions carefully before operating. VEVOR reserves clear interpretation of our user manual. The appearance of the product shall be subject to the product you received. Please forgive us that we won't inform you again if there is any| technology or software updates on our product.

1. Place the Panel mounting hole facing upwards, install the round pipe into the hole, fix it with **M6 socket screws**, **Φ6 gaskets** and have a torque greater than or equal to 25N.m

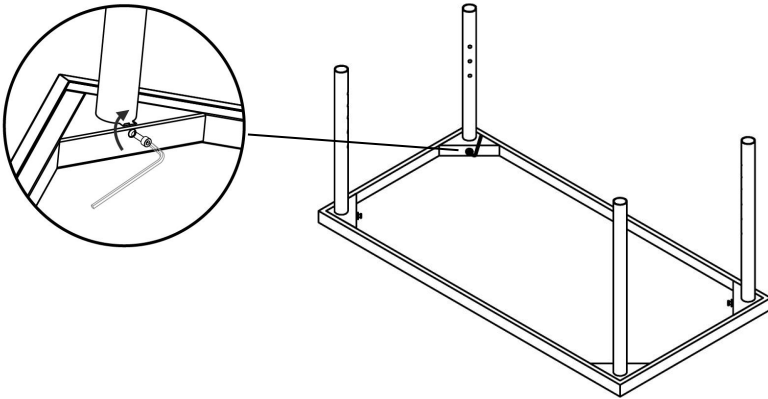

2. Some models distinguish the model of the upper and lower support pipes, and the upper and lower support pipes need to be covered  
Note: This step can be omitted for products with whole legs;

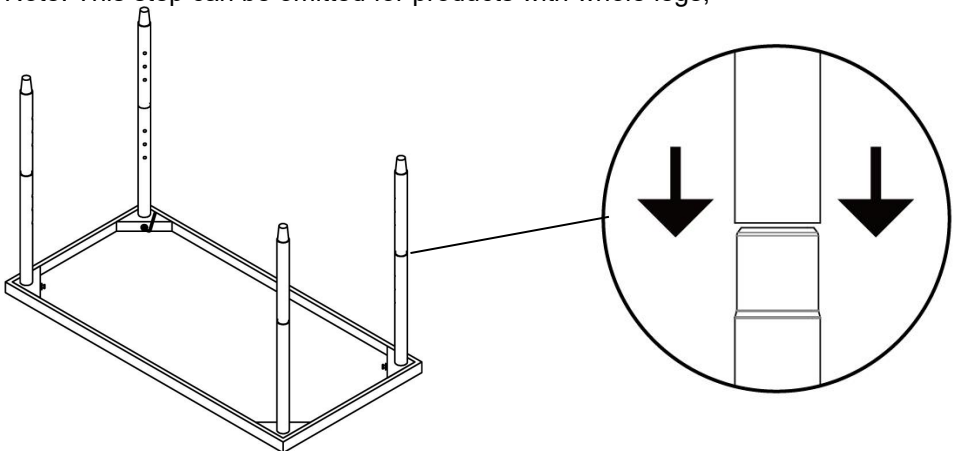

3. Install the Shelves according to the height of the hole position you need, fix the mounting hole with **M6 socket screws**, **Φ6 gaskets** and the torque is greater than or equal to 25N.m

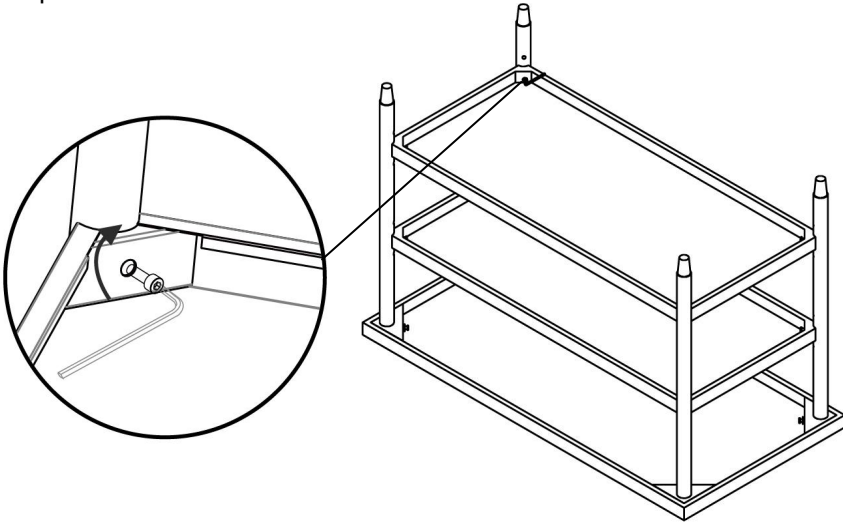

4. After completed the installation, turn the workbench over and adjust the height of the four support feet to ensure that the four feet are close to the ground and the workbench is stable

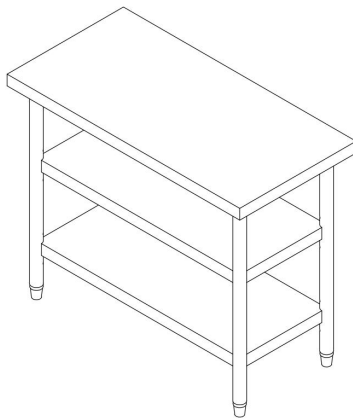

**Note: The workbench has a maximum weight limit, please be careful not to exceed the maximum weight**