

# ASSEMBLY INSTRUCTION

## ▽ Part sheet:

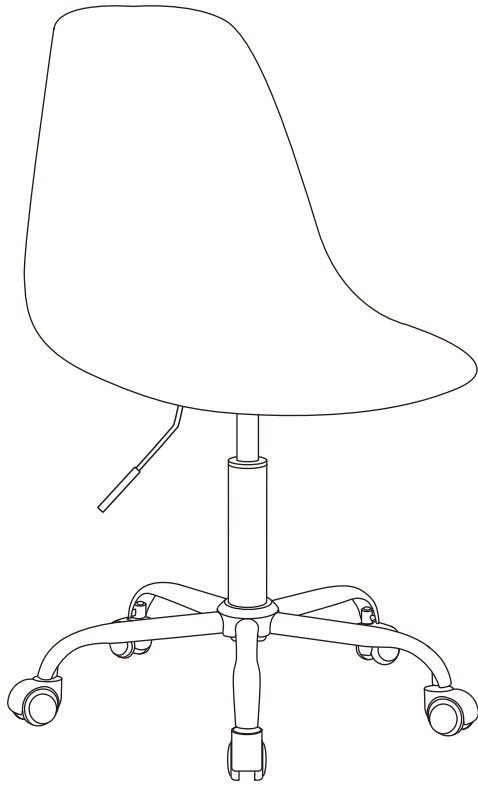

[A] Gas lift 1pc  
[A] Elevacion de gas



[B] Chair base 1pc  
[B] Base de la silla

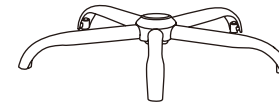

[C] Rolling castor 5pcs  
[C] Rodillo de castor



[D] Seat 1pc  
[D] Asiento

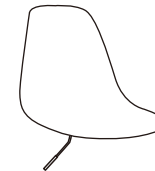

For missing parts or help assembling do not return to store, please contact

customer service

Para la piezas que faltan o ayuolar a construir, por favor no volver a almacenar por favor contacto  
servicio al cliente

# ▽ Assembly steps:

1

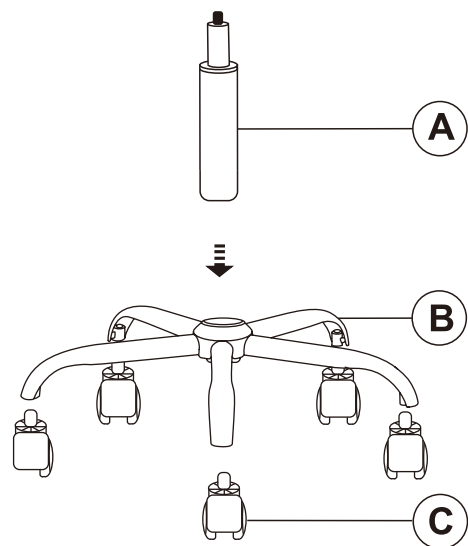
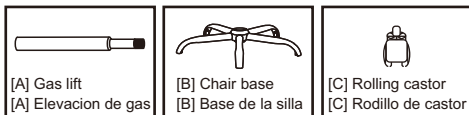

## NOTICE!

Remove and discard the black protective cap from the end of gas lift(A) before assembling!

- 1) Insert 5 rolling castors(C) into the holes of the chair base(B).
- 2) Insert the gas lift(A) into the center of base(B). These parts will lock together once it is fully assembled.

## AVISO!

Retire y deseche la tapa protectora Negra del extremo del elavader de gas antes de montar

- 1) Insertar 5 (C) rodachines decastors en oripicio de la (B) base de la silla.
- 2) Insete el (A) elvador de gas ene centro d la (B) base estas piezas se bloquearan una vez que esto completamente asentada.

2

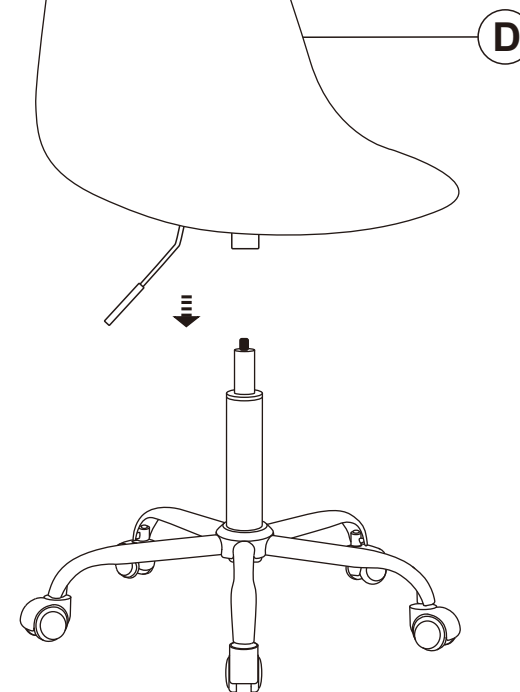

Connect the 2 assembled parts by applying downward force. If you can raise the bar stool by lifting the lever then the chair is locked together.

Conecte las 2 piezas ensambladas aplicando fuerza hacia abajo si usted puede levantar el taburete de la barra levantado la palanca entonces la silla es bloaueada junta.