

Nouveau Collection

Grab Bar Specifications

Bold and distinct, the Nouveau collection offers sophisticated simplicity for any modern bathroom.

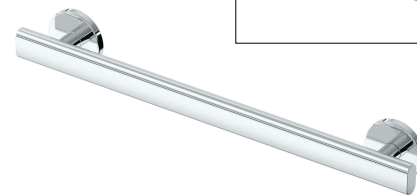

FEATURES & MATERIAL

GATCO's Grab Bars meet all Americans with Disability Act (ADA) & ASTM guidelines.

- Compatible with all major grab bar fastening systems
- Supports a minimum of 250lbs when properly installed
- 1 1/4 in. O.D. high caliber stainless steel bar
- Compliant to ICC/ANSI A117.1 accessibility standards
- Includes a LIFETIME WARRANTY

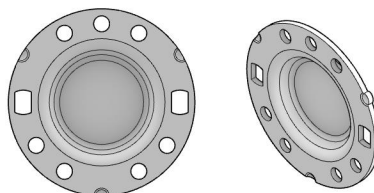

Mounting Bracket



DIMENSIONS

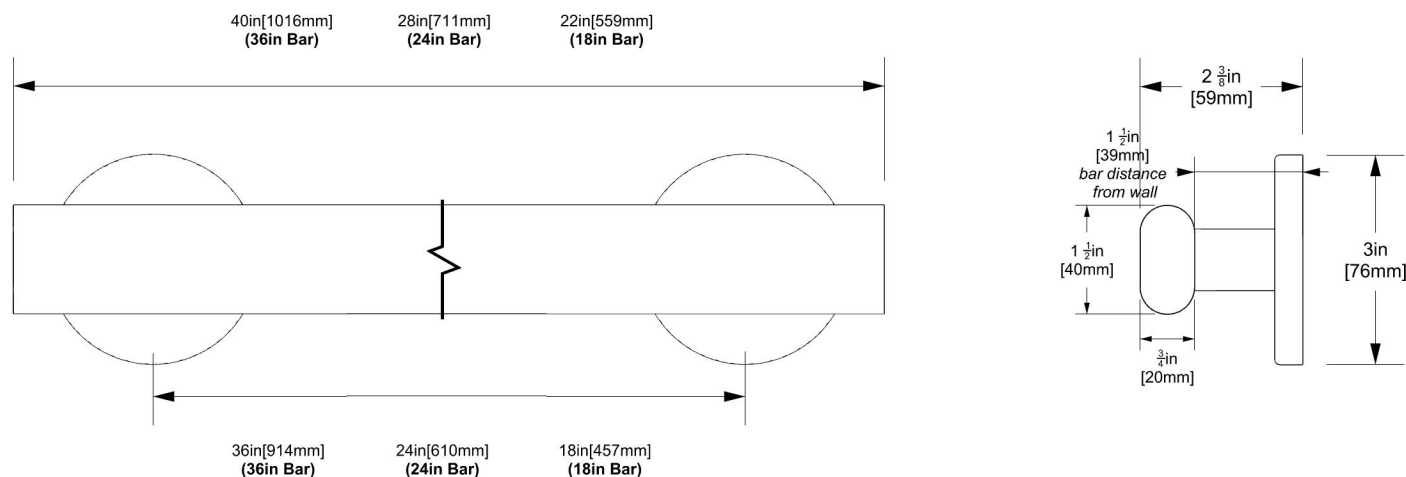

Backed by our lifetime warranty, you can trust our products to always exceed your expectations and live up to their name.



1550 Factor Ave. San Leandro, CA 94577
Phone #: 800.227.5640
Email: cs@gatcoinc.com

The manufacturer reserves the right to, and do time to time, make changes and improvements in designs and dimensions.
Updated on January 27, 2025