

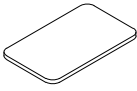

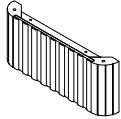

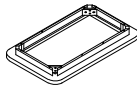

ASSEMBLY INSTRUCTION

Thank you for purchasing this quality product. Be sure to check all packing material carefully for small parts which may have come loose inside the carton during shipment. Separate, identify and count all parts and metal hardware. Compare with parts list to be sure all parts are present. If any part(s) are missing or damaged, please contact your local furniture dealer. For efficient and speedy service, please indicate the model number and code letter of part(s) needed.

*** Do not fully tighten screws until fully assembled ***

No.	COMPONENT LIST		Q'ty	No.	COMPONENT LIST		Q'ty
Ⓐ		TABLE TOP	1pc	Ⓑ		SIDE FRAME	2pcs
Ⓒ		BOTTOM FRAME	1pc	Ⓓ		LEGS	4pcs
No.	HARDWARE LIST		Q'ty	No.	HARDWARE LIST		Q'ty
①		Bolts 1/4"x1.4"	16	②		Spring washers Ø1/4"x 1/2"	16
③		Flat washers Ø1/4"x 0.6"	16	④		Wood Dowel	8
⑤		Allen key K4	1	Step 2: Align and place Legs (D) into Bottom frame (C). Then use Bolts (1), Spring washer (2), Flat washer (3) and Allen Key (5) connect. Fully tighten all bolts.			

Step 1: Take the Wood Dowel (4)Put into Table Top(A) . Then Connect Side frame(B) with Bolts (1),Spring Washer (2) and Flat washer (3) .Do not tighten all bolts.

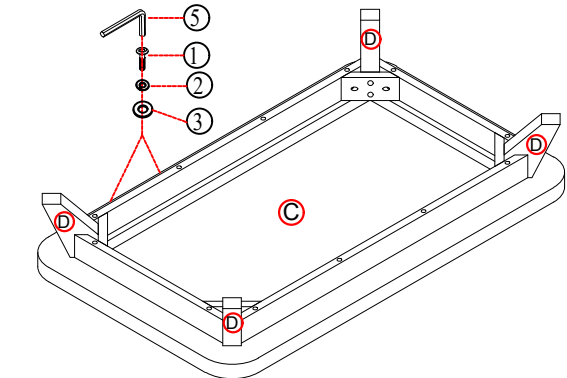
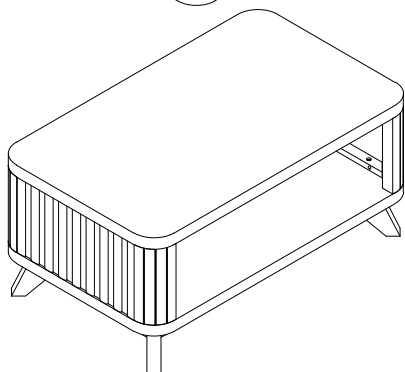
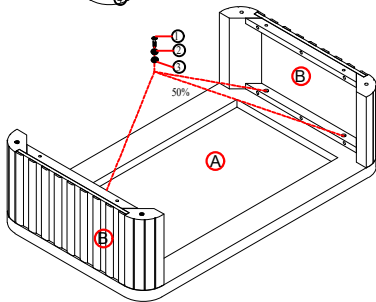
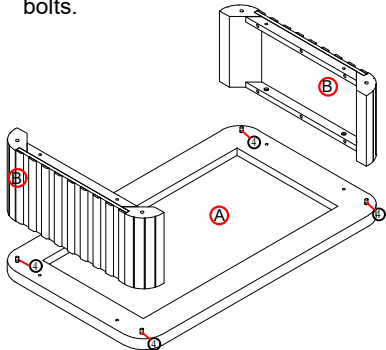

Step 3: Take the Wood Dowel (4)Put into Bottom frame (C) . Then Connect Side frame(B) with Bolts (1),Spring Washer (2) and Flat washer (3) .Fully tighten all bolts.

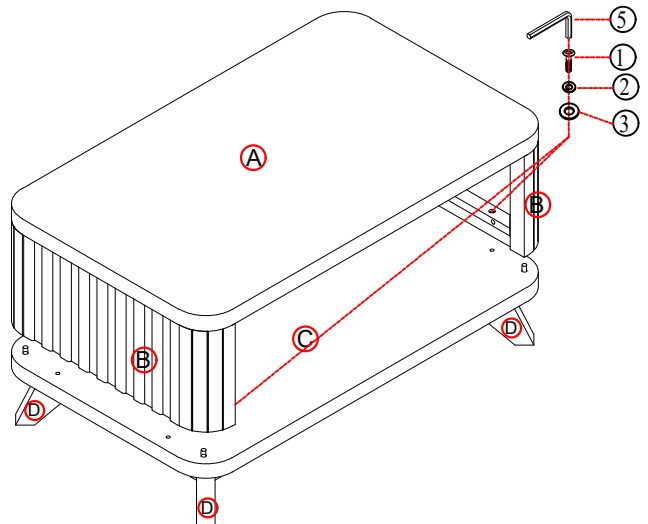

FINISH .
THANK YOU !