



INSTRUCTION MANUAL/BEDIENUNSANLEITUNG/
NOTICE D'UTILISATION/MANUAL DE INSTRUCCIONES

Six Drawer Cabinet

! WARNING!

Adults assembly required. During assembly, keep all parts away from children. Check regularly to ensure all fasteners are tight.

! WARNUNG!

Die Montage ist von Erwachsenen durchzuführen. Halten Sie während der Montage alle Teile von Kindern fern. Überprüfen Sie regelmäßig den festen Sitz der Schrauben.

! Attention!

Montage à effectuer par des adultes. Pendant le montage, tenez les éléments éloignés des enfants. Vérifiez régulièrement que toutes les vis soient serrées.









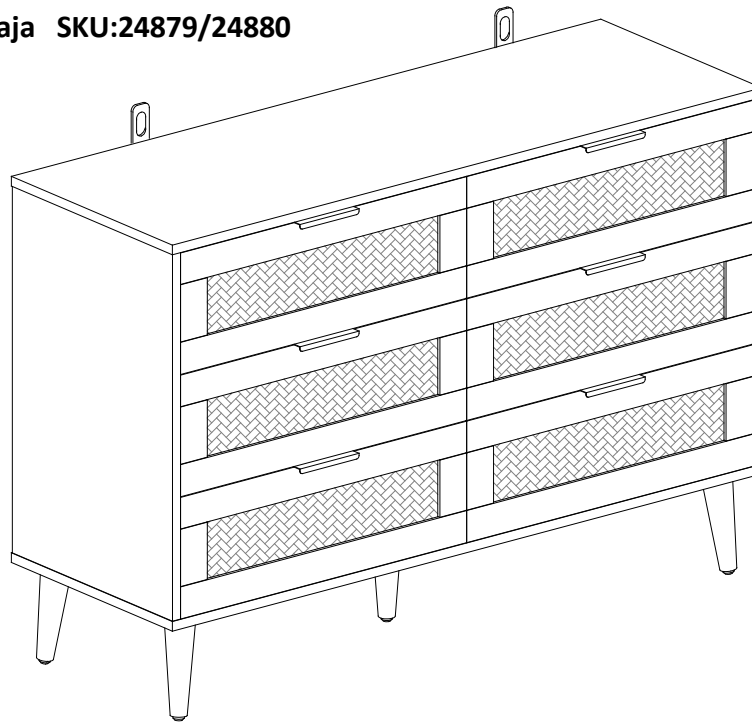

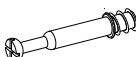

! ¡Atención!

Se requiere que el montaje sea llevado a cabo por un adulto. Durante el montaje, mantenga todas las piezas fuera del alcance de los niños. Verifique regularmente que todos los tornillos estén correctamente apretados.

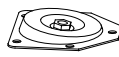
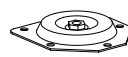
Parts List/Stückliste/Parts List/Listado de piezas:

Carton/Karton/Carton/Caja SKU:24879/24880

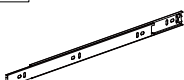

A x34 	B x34 	C x48  3.5x12mm	D x12  8x30mm	E x7  M7X38MM	F x1  M4
G x26  3.5x30mm	H x4 	J x1 	K x20  4x14mm	L1 x6  L2 x6 3.5x12mm 	M x12 
RETAIN FOR FUTURE REFERENCE FÜR KÜNFTIGE VERWENDUNG AUFBEWAHREN A CONSERVER POUR UNE UTILISATION FUTURE CONSERVAR PARA SER LEÍDO POR CADA NUEVO USUARIO, ANTES DE UTILIZAR EL ARTÍCULO POR PRIMERA VEZ				N x2 	P x2 

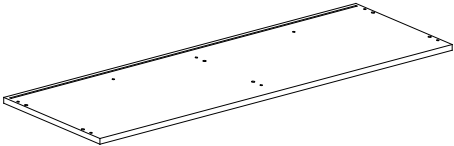
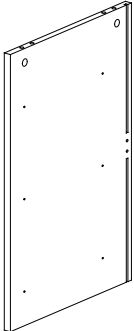
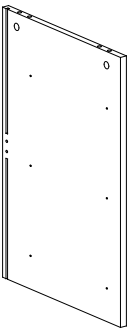
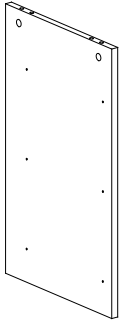
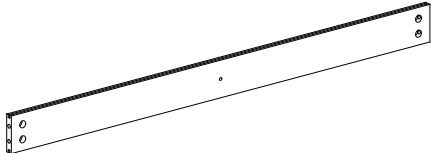
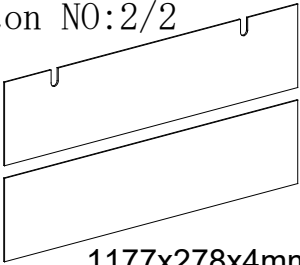
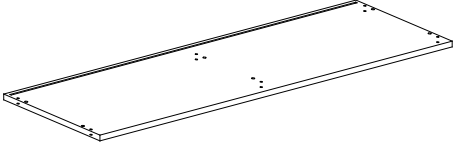
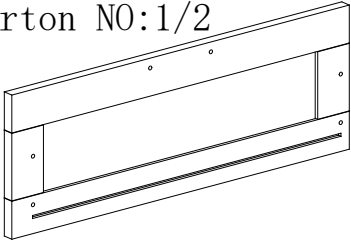
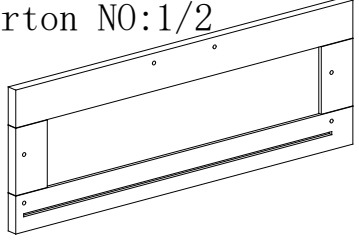
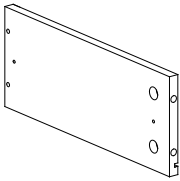
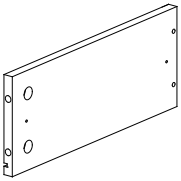
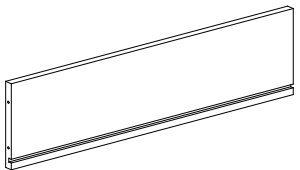
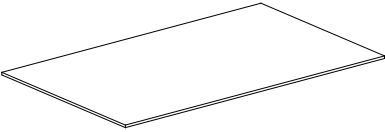
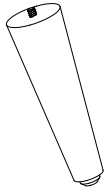
<p>① Top panel Carton NO:2/2</p>  <p>1200x390x15mm x1</p>	<p>② Side panel Carton NO:2/2</p>  <p>580x389x15mm x1</p>	<p>③ Side panel Carton NO:2/2</p>  <p>580x389x15mm x1</p>
<p>④ Middle panel Carton NO:1/2</p>  <p>580x354x15mm x1</p>	<p>⑤ Back panel Carton NO:2/2</p>  <p>1169x70x15mm x1</p>	<p>⑥ Back panel Carton NO:2/2</p>  <p>1177x278x4mm x2</p>
<p>⑦ Bottom panel Carton NO:2/2</p>  <p>1200x390x15mm x1</p>	<p>⑧ Draw panel Carton NO:1/2</p>  <p>581x190x15mm x3</p>	<p>⑨ Draw panel Carton NO:1/2</p>  <p>581x190x15mm x3</p>
<p>⑩ Drawer side panel Carton NO:1/2</p>  <p>300x130x15mm x6</p>	<p>⑪ Drawer side panel Carton NO:1/2</p>  <p>300x130x15mm x6</p>	<p>⑫ Drawer back panel Carton NO:1/2</p>  <p>522x130x15mm x6</p>
<p>⑬ Drawer bottom panel Carton NO:1/2</p>  <p>530x293x4mm x6</p>	<p>⑭ Foot</p>  <p>x5</p>	

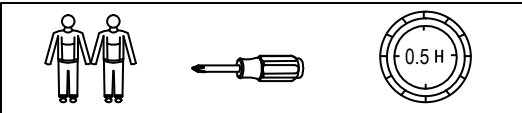
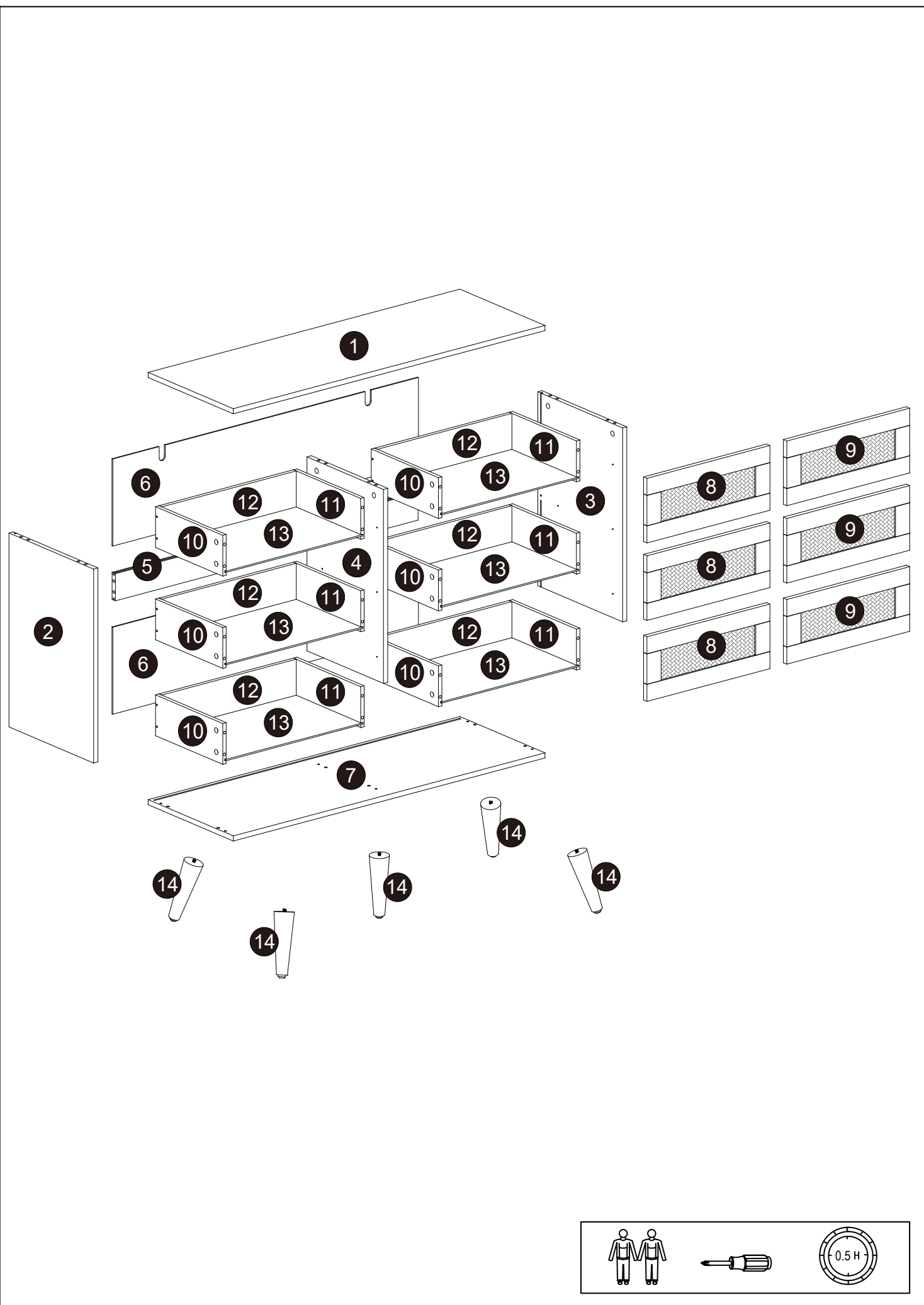

Assembly/Montage/Assemblage/Montaje:

1

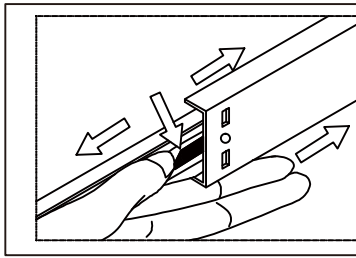

First, separate the guide rail M according to the diagram.

M

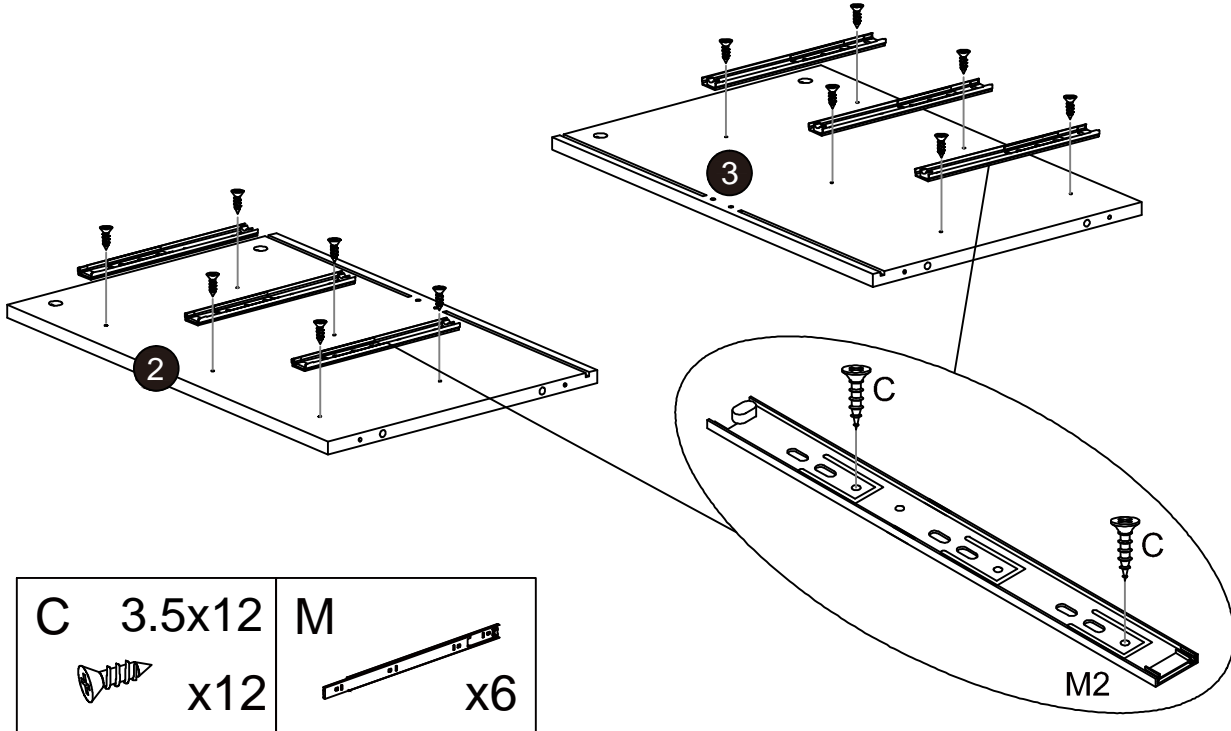
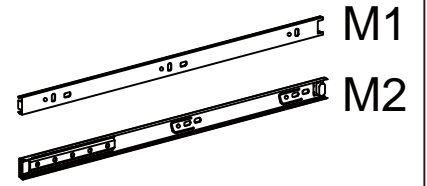

C 3.5x12
x12

M
x6

2

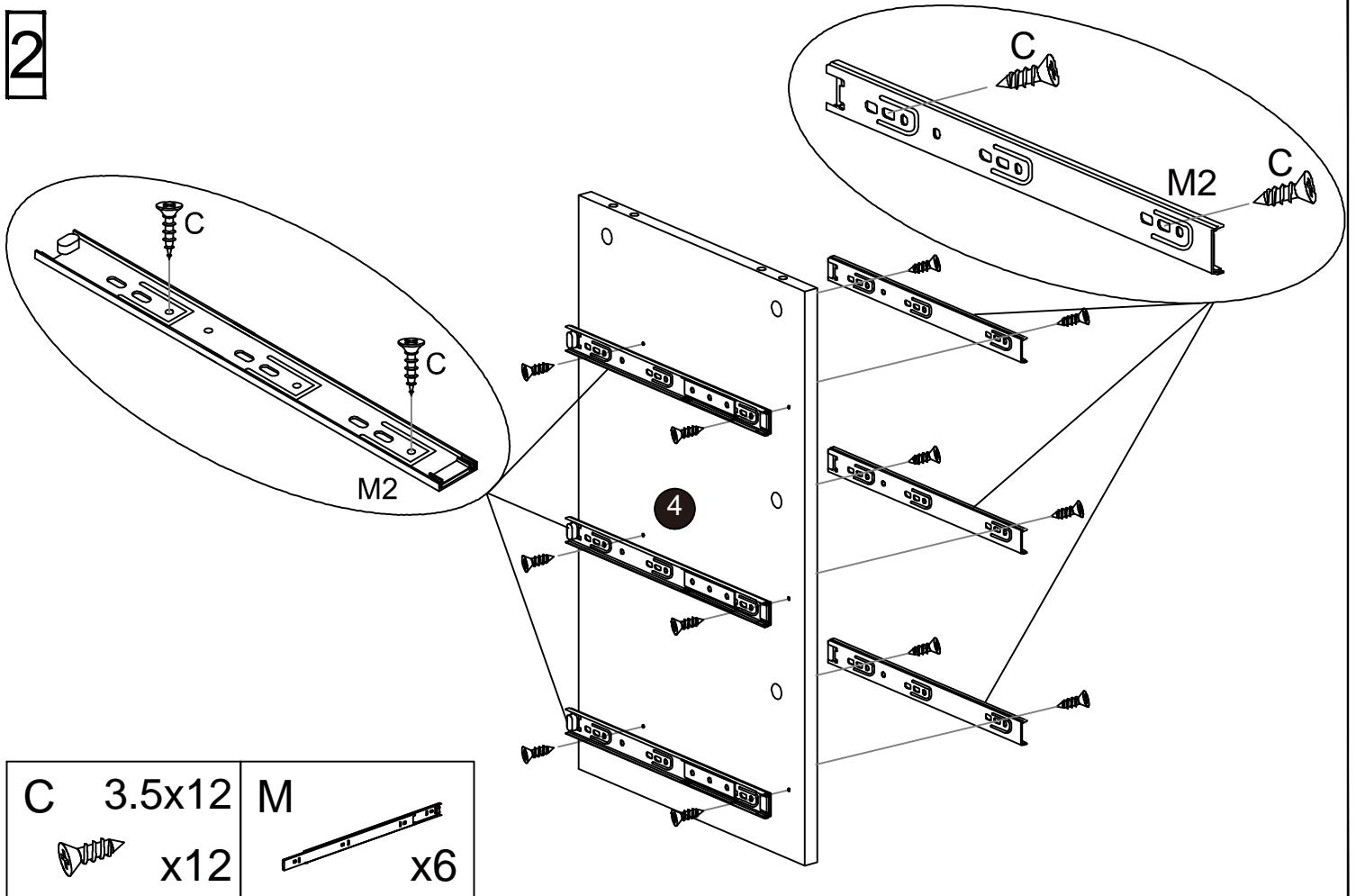



C 3.5x12
x12

M
x6

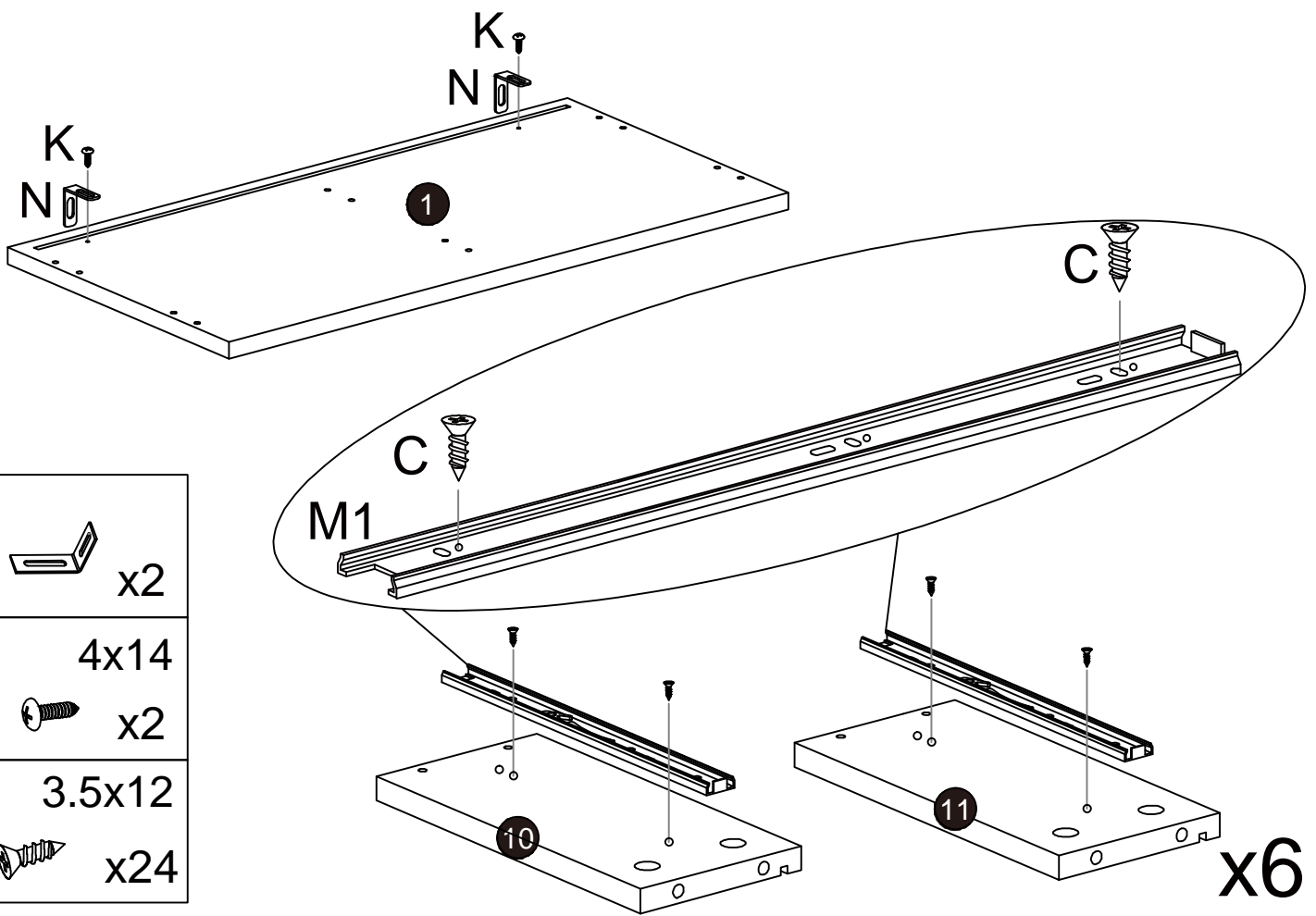

3

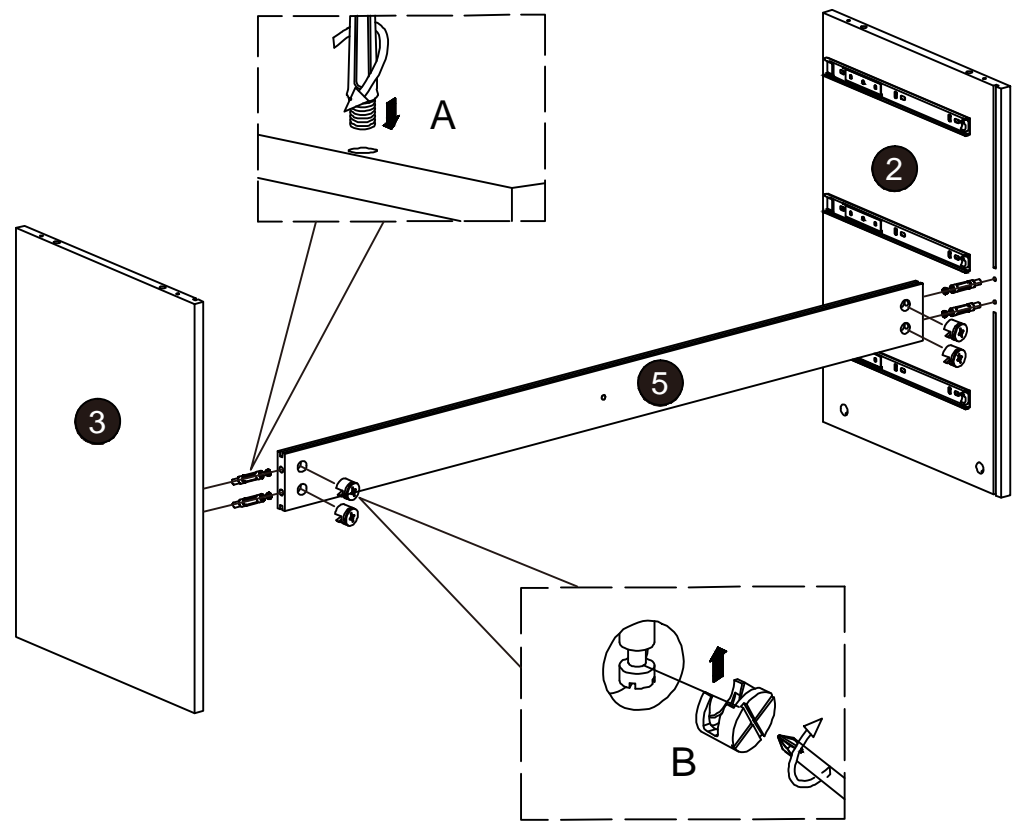

- | | | |
|---|---|---------------|
| N |  | x2 |
| K |  | 4x14
x2 |
| C |  | 3.5x12
x24 |

4



- | | | |
|---|---|----|
| A |  | x4 |
| B |  | x4 |

Assembly/Montage/Assemblage/Montaje:

5

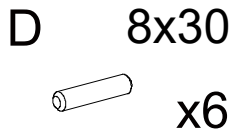
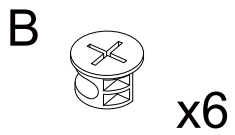
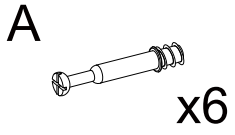
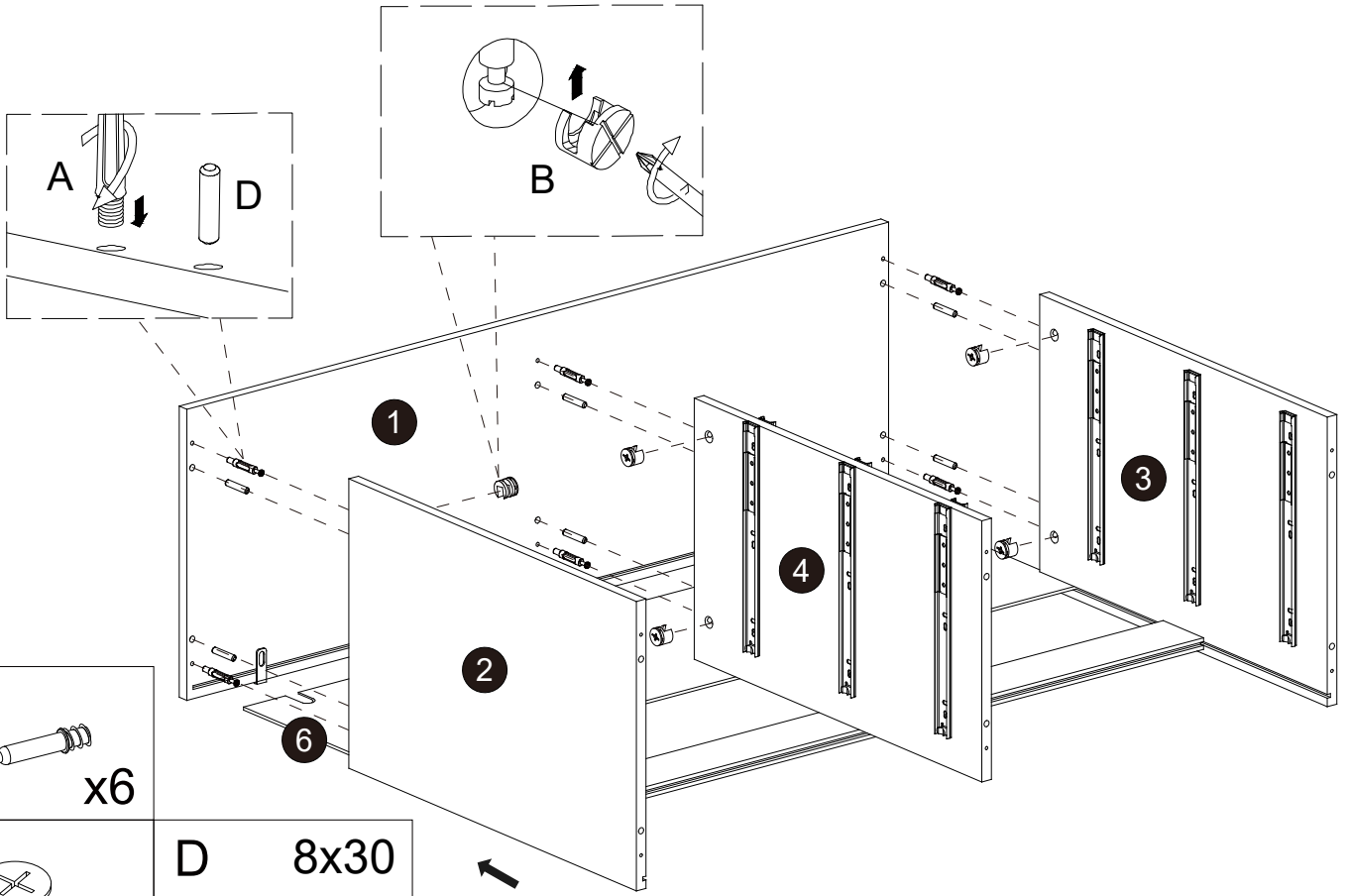

6

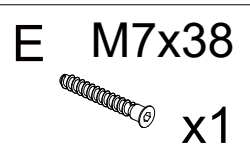
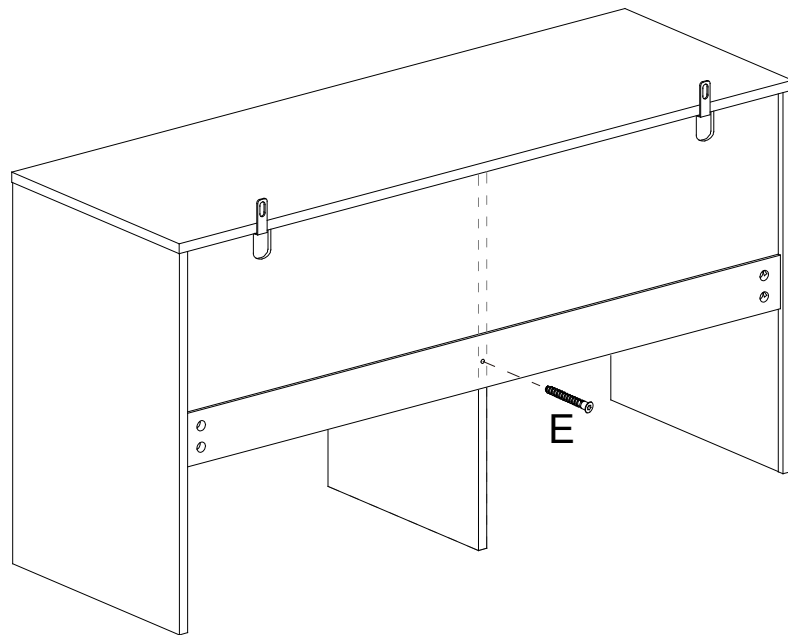

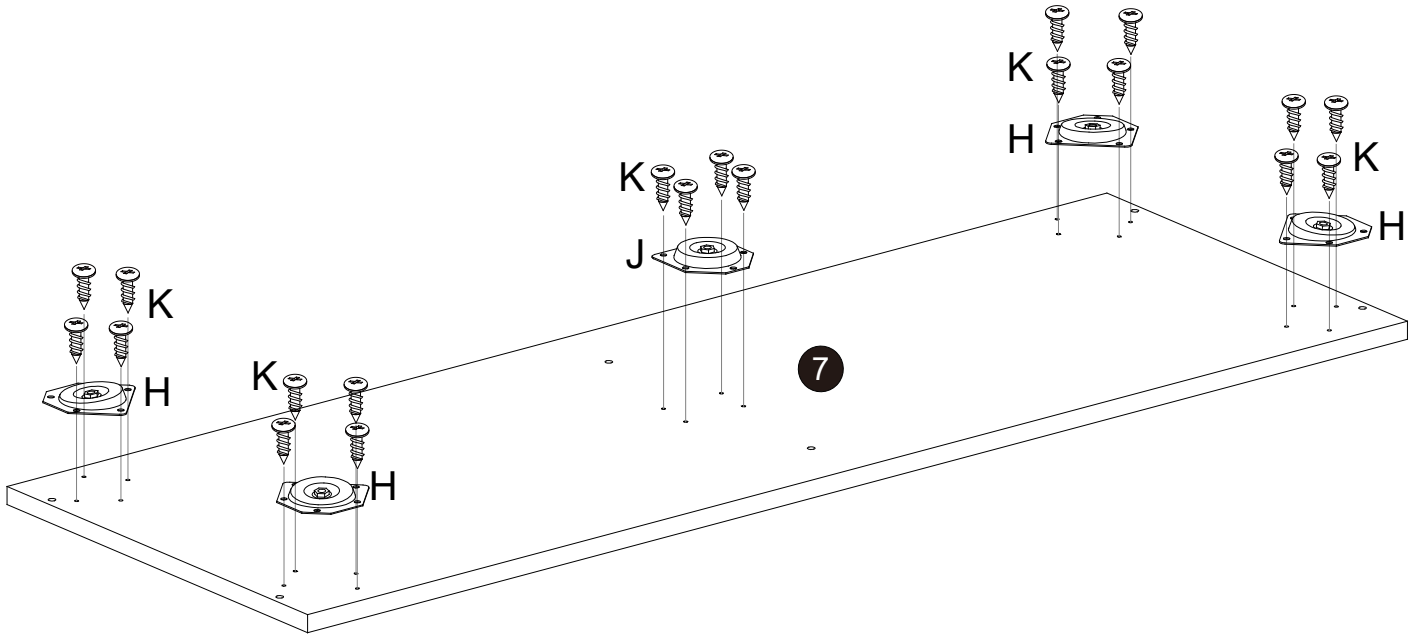

7



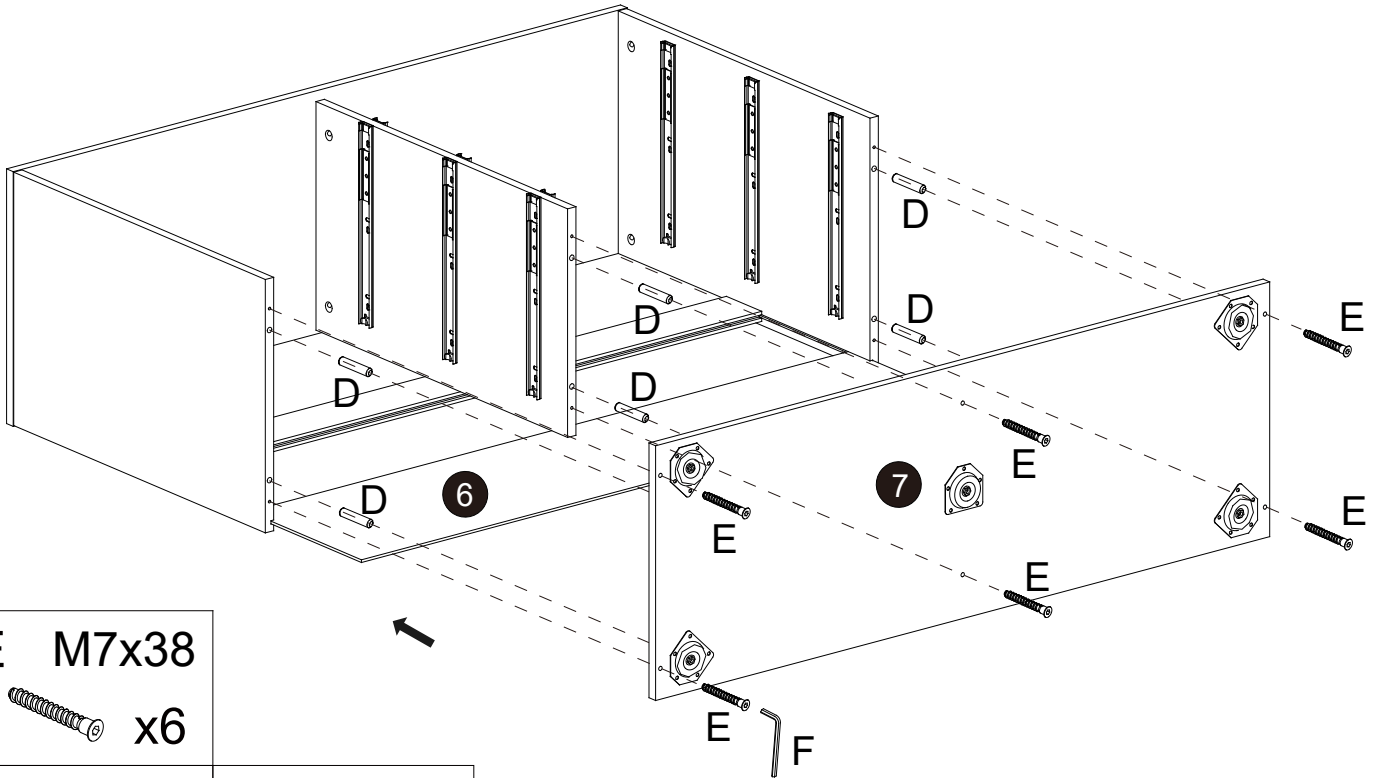

- | | |
|---|------|
| K | 4x14 |
|  | x20 |

8



- | | |
|---|-------|
| E | M7x38 |
|  | x6 |

- | | | | |
|---|----|---|------|
| F | M4 | D | 8x30 |
|  | x1 |  | x6 |

9

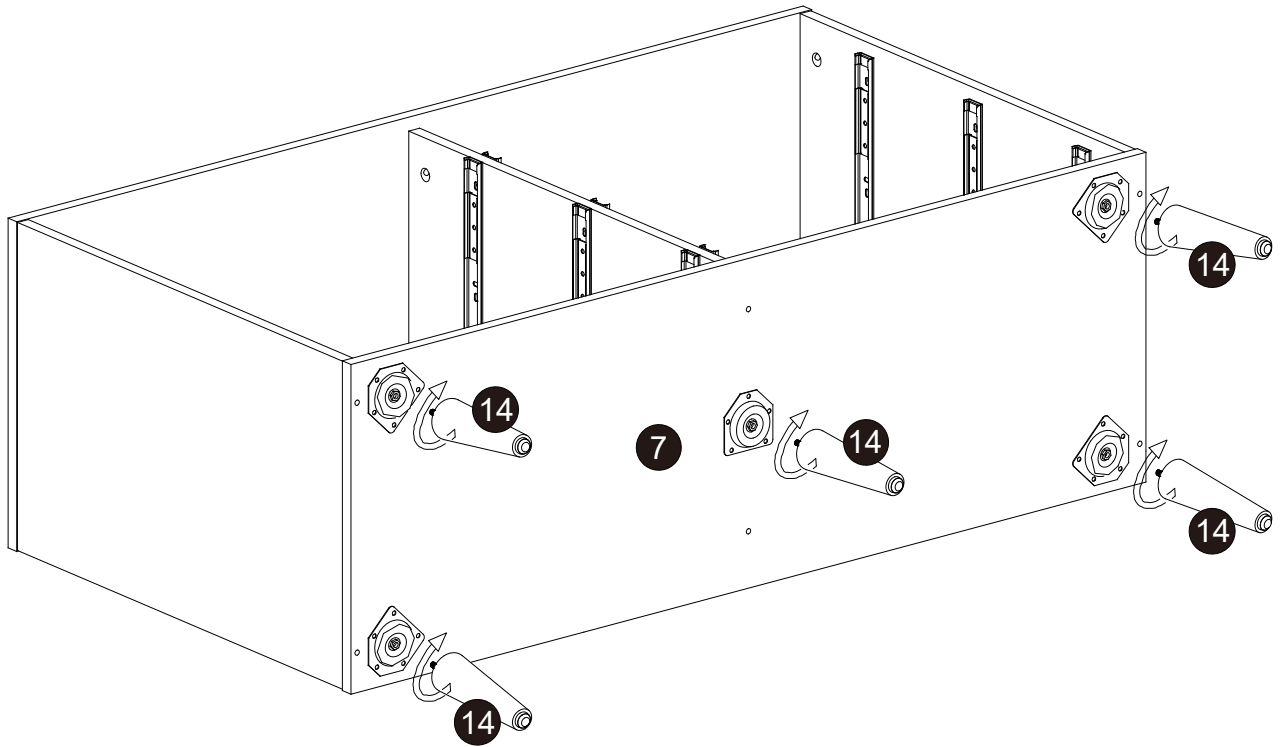

10

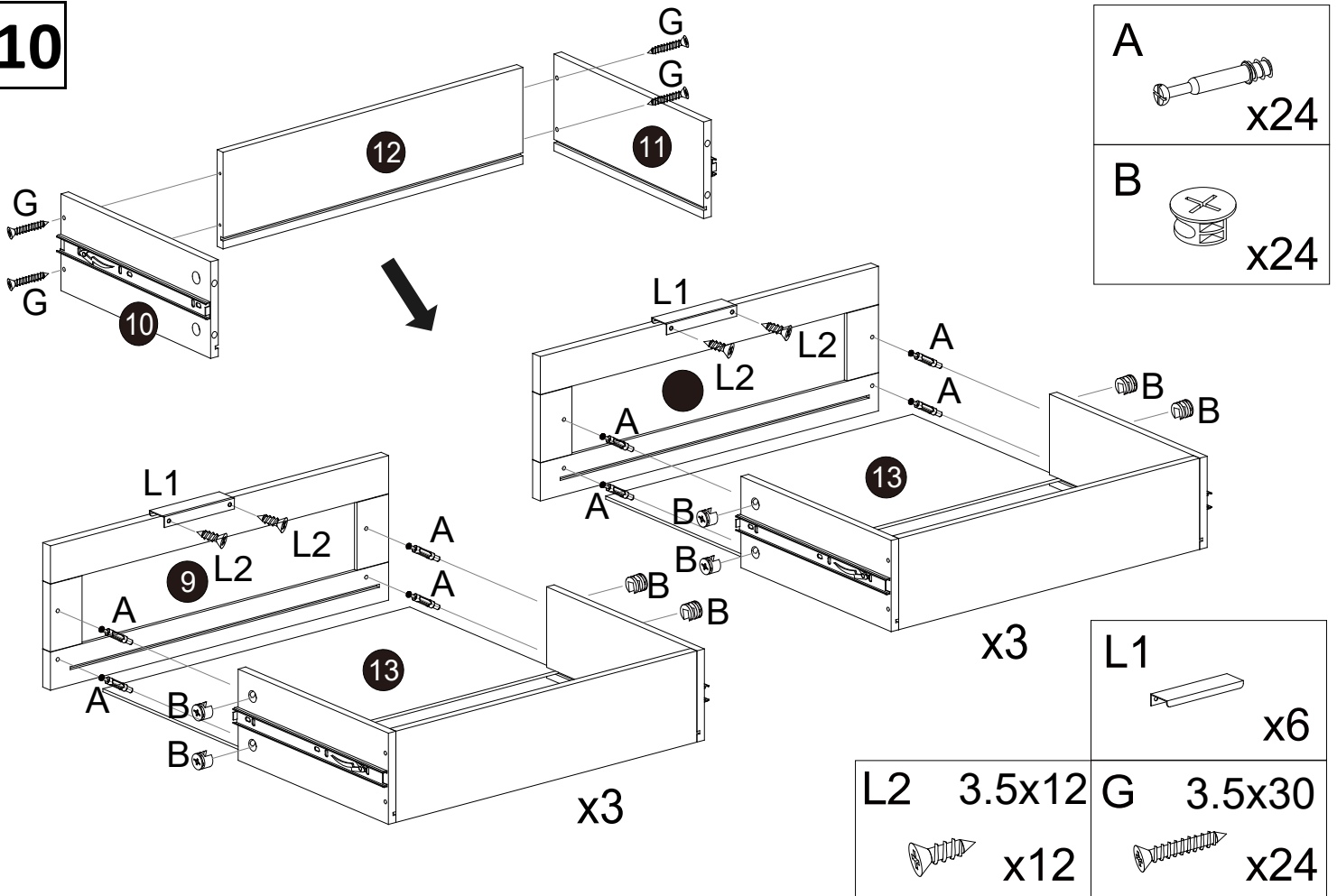

11

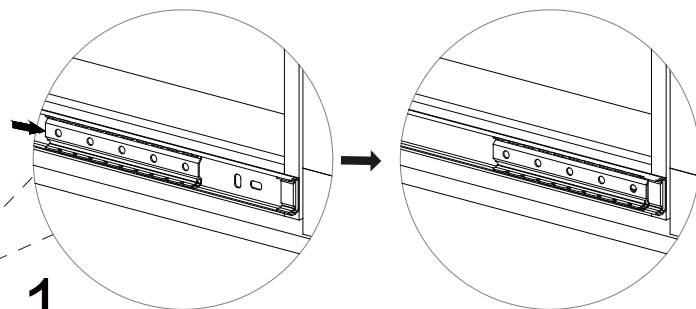
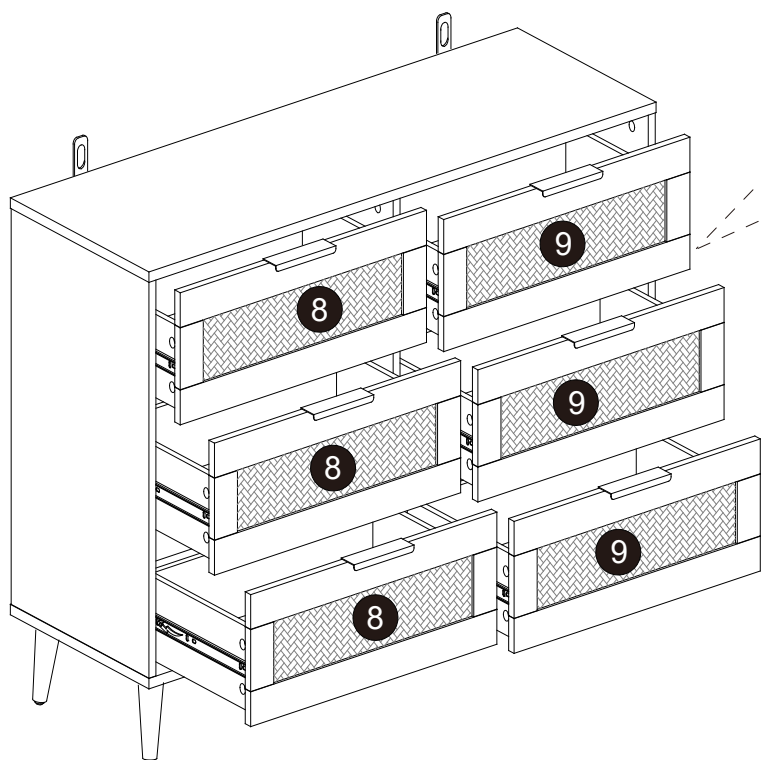

1 First, slide the iron plate on the guide rail to the far right.

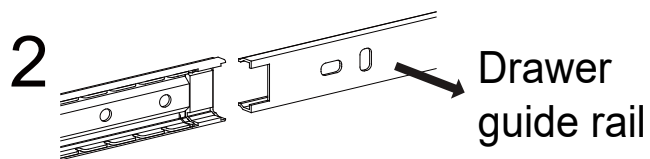

2 Pay attention to the direction of the guide rail.

12

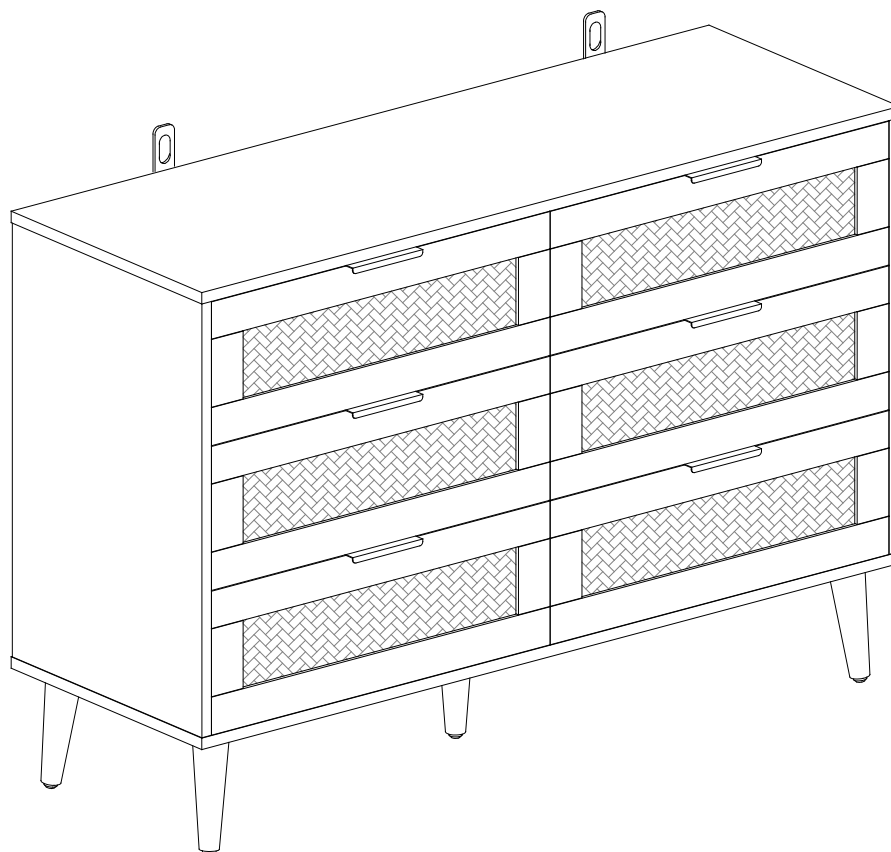

Tight all the screws to 60% first then tight to 100%.

Während der Montage alle Schrauben zuerst 60% anziehen, dann zu 100%.

Serrez toutes les vis à 60% d'abord puis serrez à 100%.

Primero apriete los tornillos al 60% y después al 100%.

CARE AND SAFETY GUIDELINES

For assistance with assembly, or to request replacement parts, log onto our website or call Customer Service.
DO NOT RETURN THE PRODUCT TO THE STORE.

Si vous avez besoin d'aide pour le montage, ou pour demander des pièces de rechange, connectez-vous sur notre site Web ou appelez le service à la clientèle. **NE RETOURNEZ PAS LE PRODUIT AU MAGASIN.**

Para obtener ayuda sobre el montaje o para solicitar piezas de repuesto, conéctese a nuestra página web o llame a Atención al cliente. **NO DEVUELVA EL PRODUCTO A LA TIENDA.**

Wenn Sie Hilfe beim Aufbau oder Ersatzteile benötigen, melden Sie sich auf unserer Webseite an oder rufen Sie unseren Kundenservice an. **GEBEN SIE DAS PRODUKT NICHT IM GESCHÄFT ZURÜCK.**

Als u hulp nodig heeft bij de montage of vervangende onderdelen wilt bestellen, kunt u inloggen op onze website of bellen met de klantenservice. **BRENG HET PRODUCT NIET TERUG NAAR DE WINKEL.**

Per assistenza al montaggio, o per richiedere pezzi di ricambio, accedi al nostro sito o chiama il servizio clienti. **NON RESTITUIRE IL PRODOTTO AL NEGOZIO.**

Para obter ajuda na montagem, ou para solicitar peças de substituição, inicie a sessão no nosso sítio da Internet ou ligue para o Serviço de Apoio ao Cliente. **NÃO DEVOLVA O PRODUTO À LOJA.**

UK

Email : help@arcaliving.com

CA

Email : help@arcaliving.com