

# METAL GARDEN SHED 4X7FT

## Instructions for Assembly

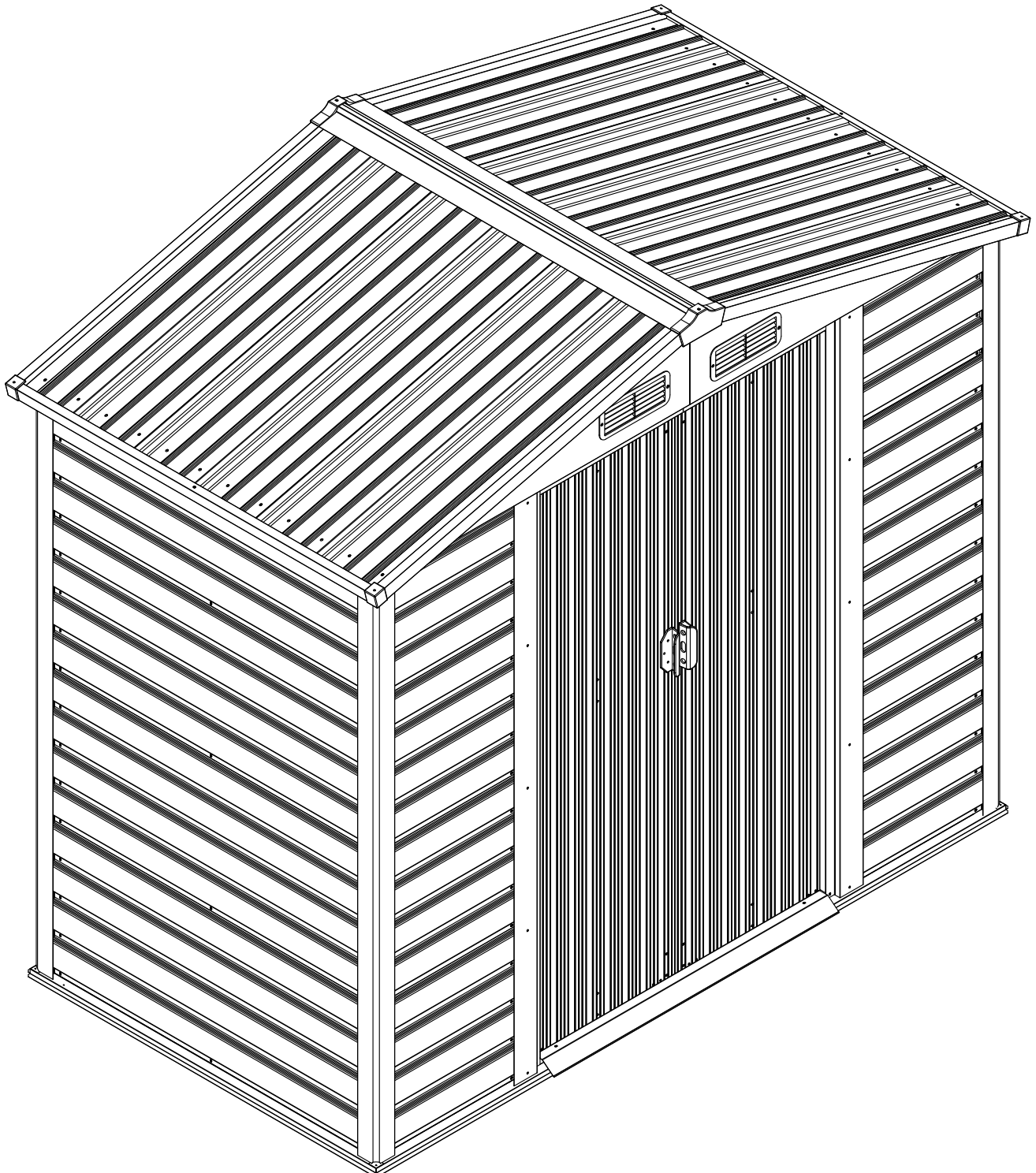





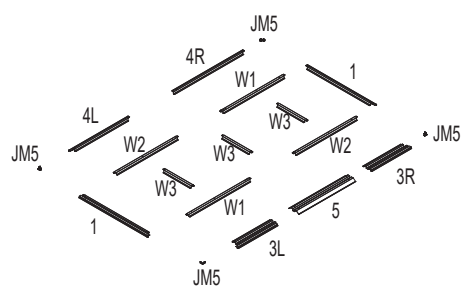
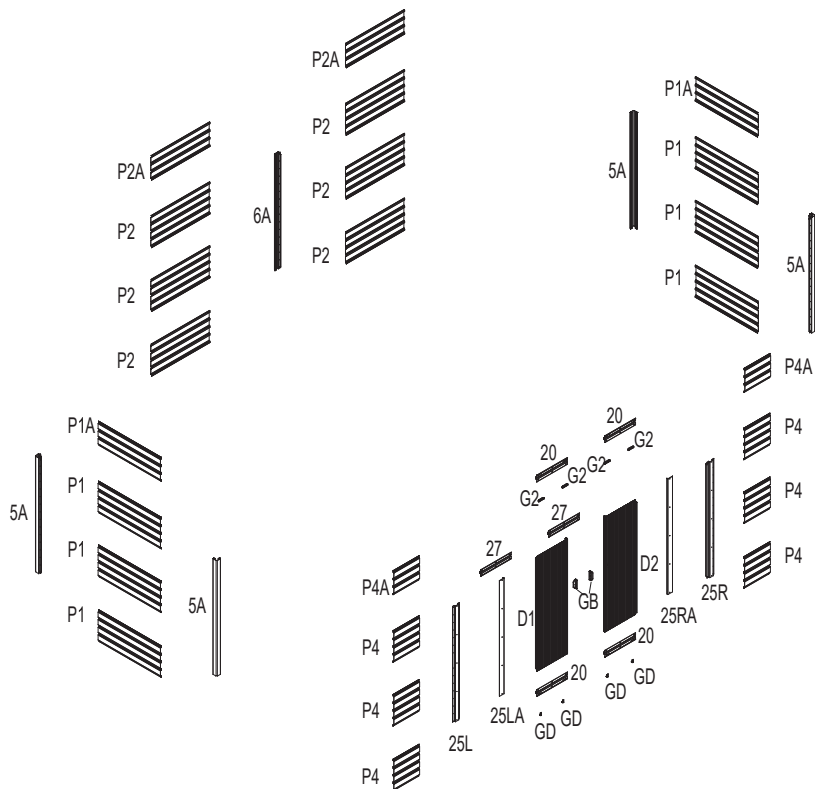
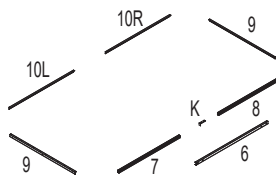
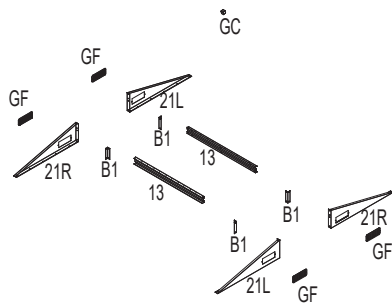
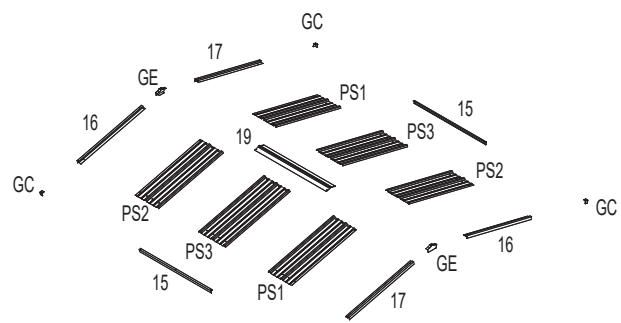

Requires two people and takes 2-3 hours for Installation.



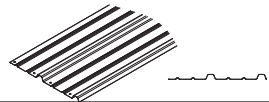
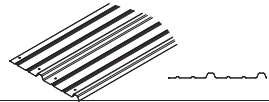
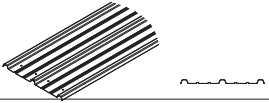

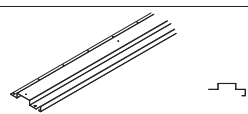
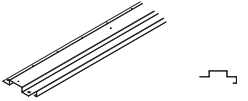
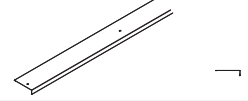
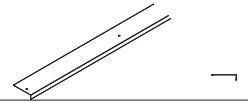

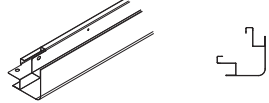

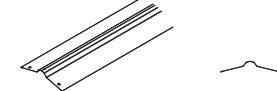
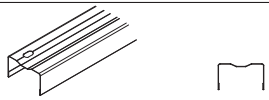

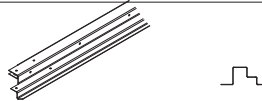
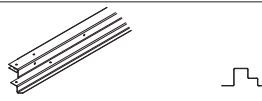
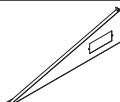
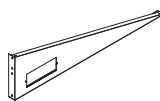
### **WARNING**

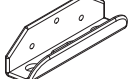
Please read the instruction manual carefully before assembly.  
Please assembly strictly in accordance with the instruction.  
Please double-check to ensure that all parts of the package contents intact.  
To avoid injury, work gloves are recommended during assembly.

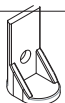

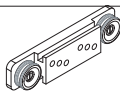

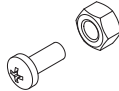

# PARTS LIST 1/2

NO.	PART	Qty.
PS1		2
PS2		2
PS3		2
7		1
8		1
25L		1
25R		1
25LA		1
25RA		1
D1		1
D2		1
5A		4
6A		1
19		1
6		1

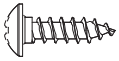
NO.	PART	Qty.
4L		1
4R		1
21L		2
21R		2
K		1
GF		4
GB		2
GC		4
GD		4
GE		2
JM5		4
G2		4
F1		343
F2		76
15		2







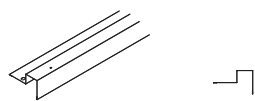
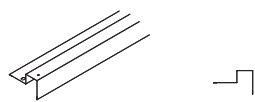
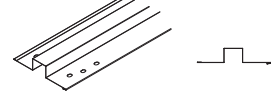
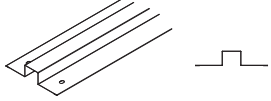
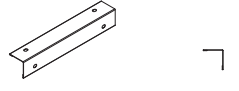
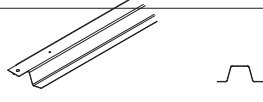
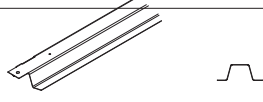
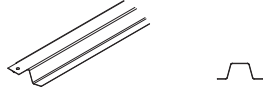

# PARTS LIST 1/2

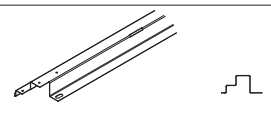
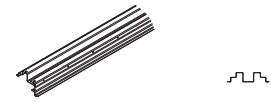
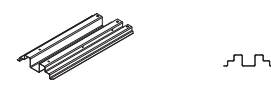

NO.	PART	Qty.
F3		8
S1		329
S2		306
F6		4

# PARTS LIST 2/2

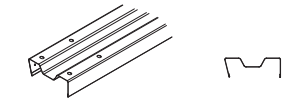
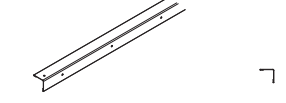
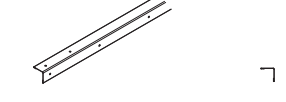
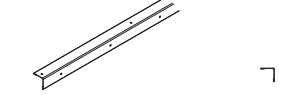

16		2
17		2
20		4
27		2
B1		4
W1		2
W2		2
W3		3

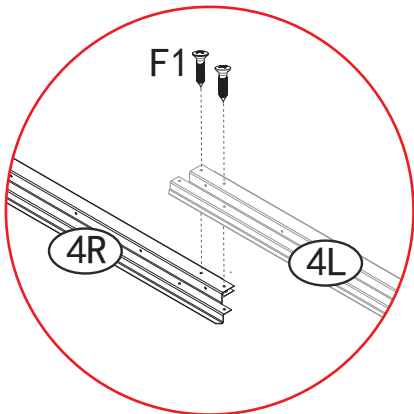
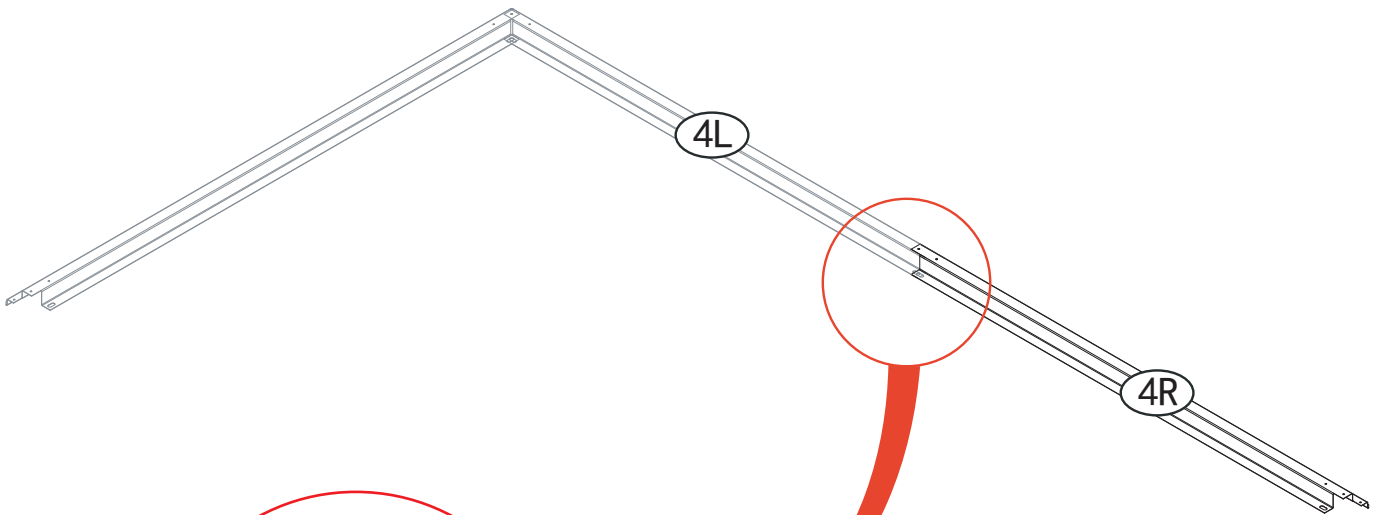
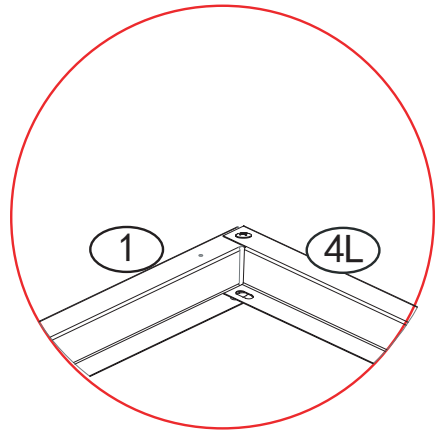
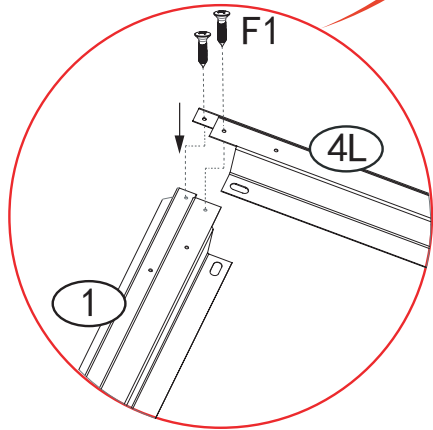
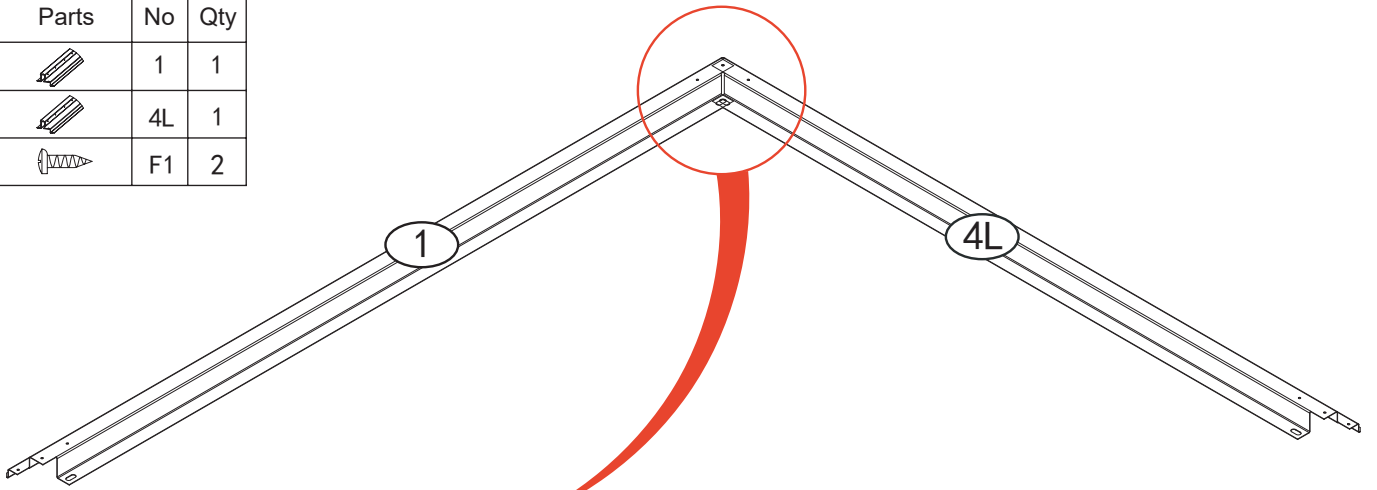

# PARTS LIST 2/2

NO.	PART	Qty.
1		2
3L		1
3R		1
5		1
P1		6
P1A		2
P2		6
P2A		2
P4		6
P4A		2
13		2
9		2
10L		1
10R		1



Parts	No	Qty
	1	1
	4L	1
	F1	2



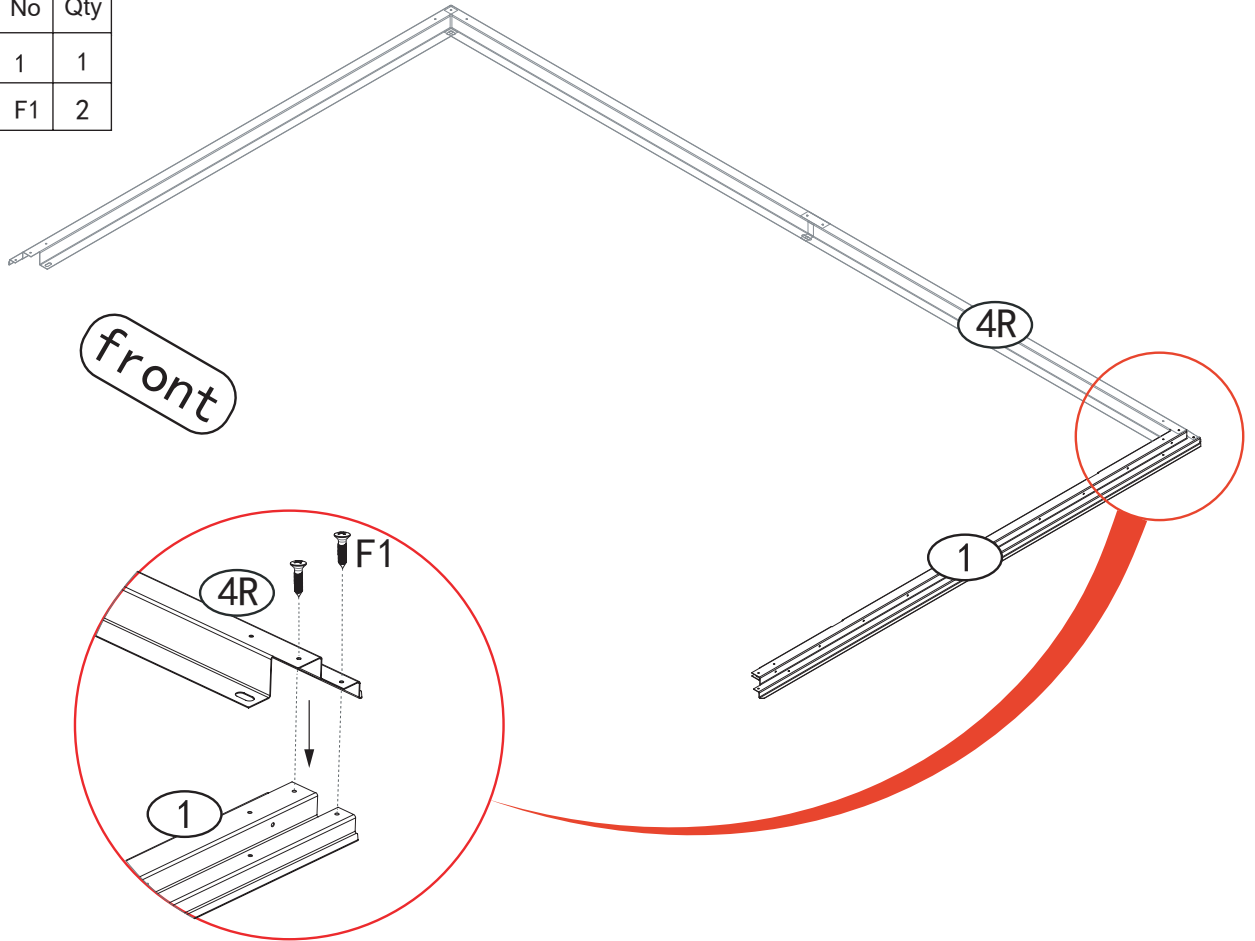

Parts	No	Qty
	4R	1
	F1	2

Parts	No	Qty
	1	1
	F1	2



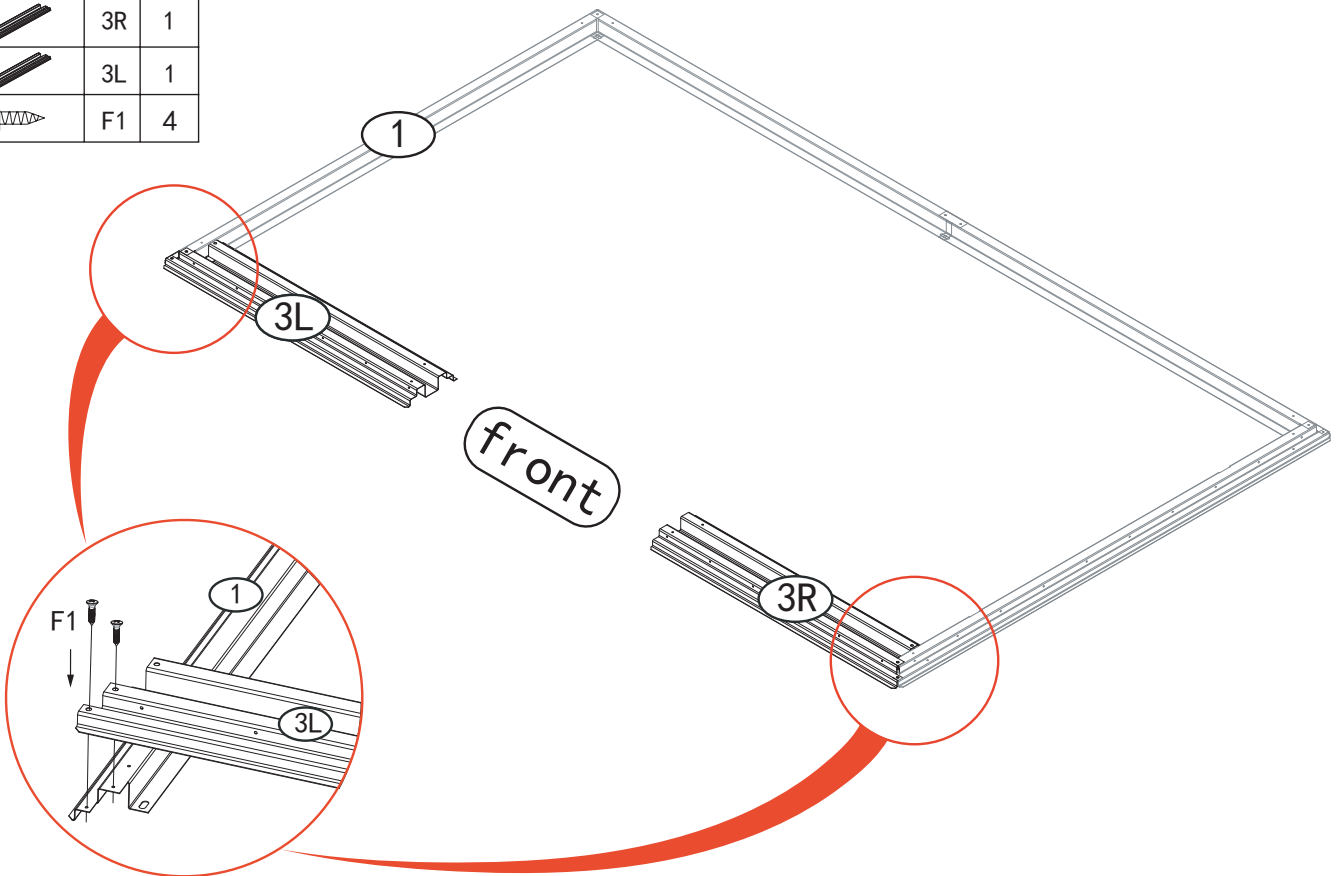





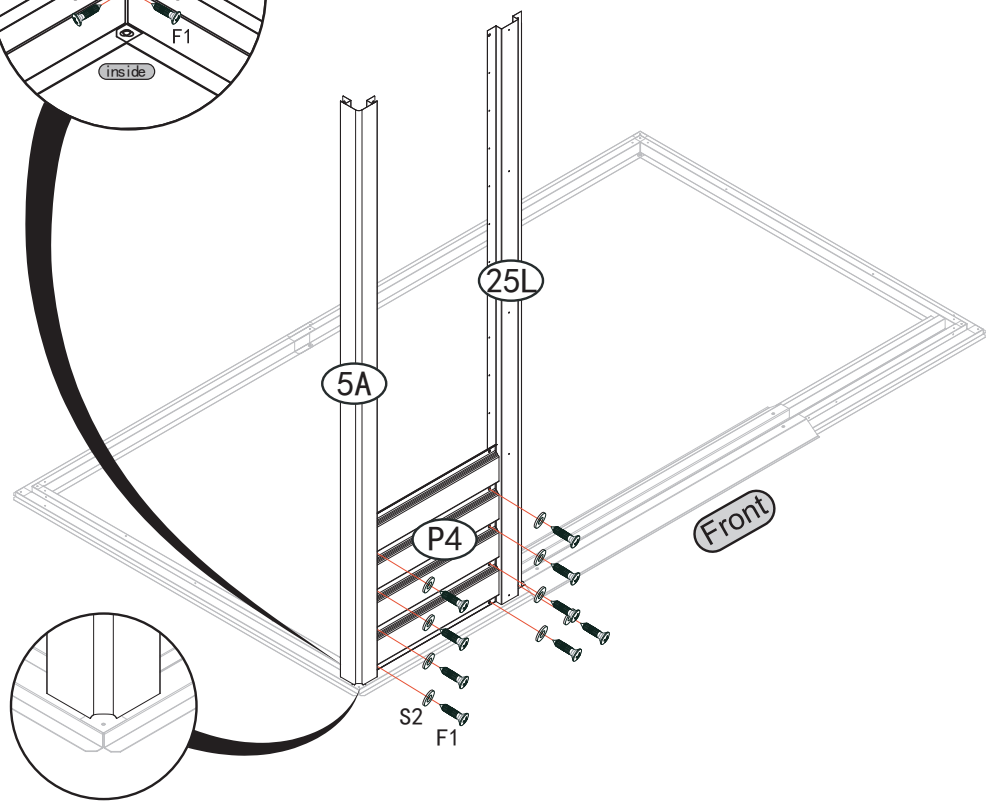
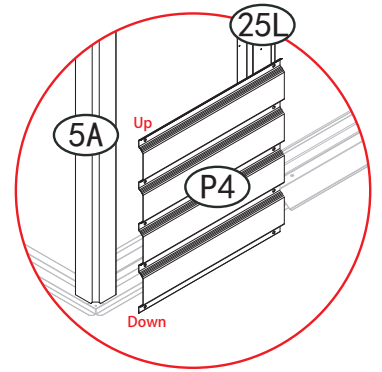
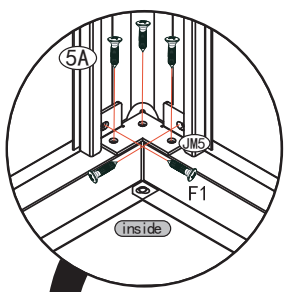
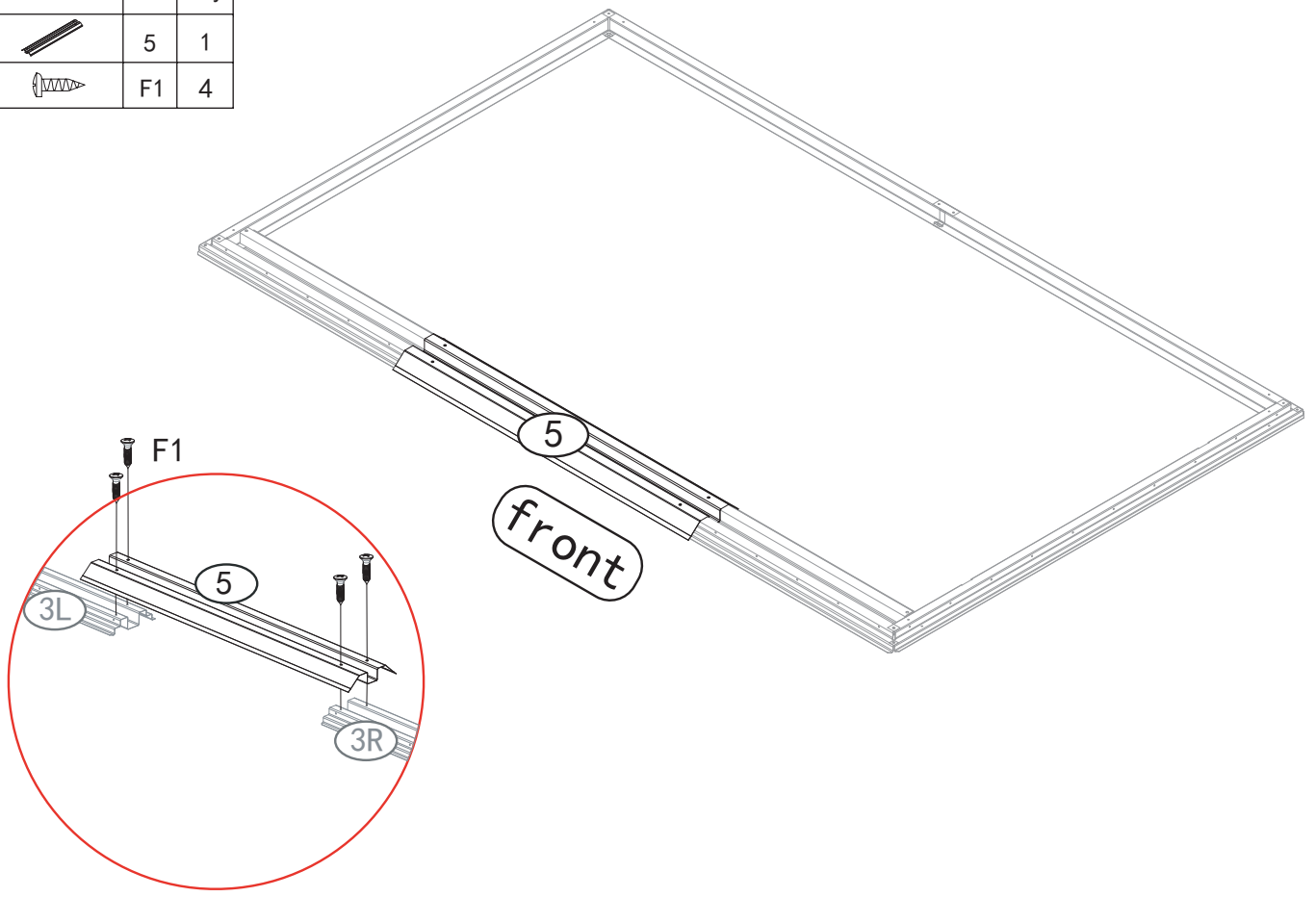



Parts	No	Qty
	3R	1
	3L	1
	F1	4







Parts	No	Qty
	5	1
	F1	4



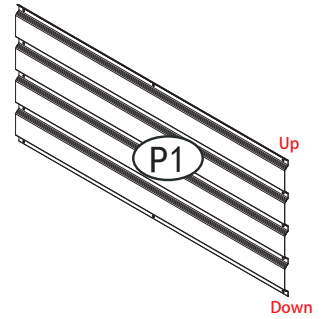
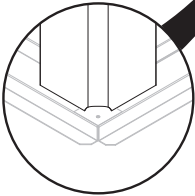
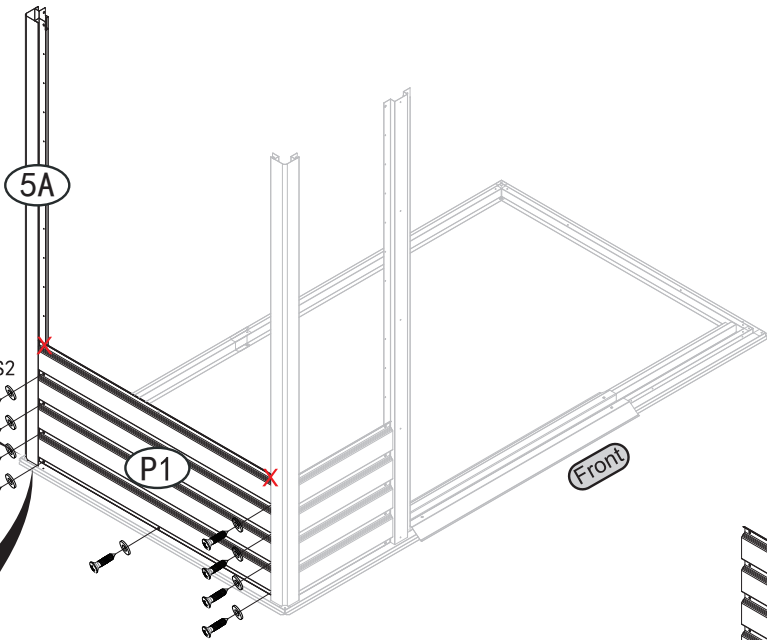
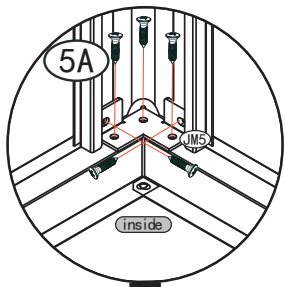



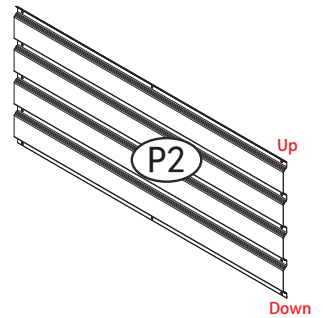
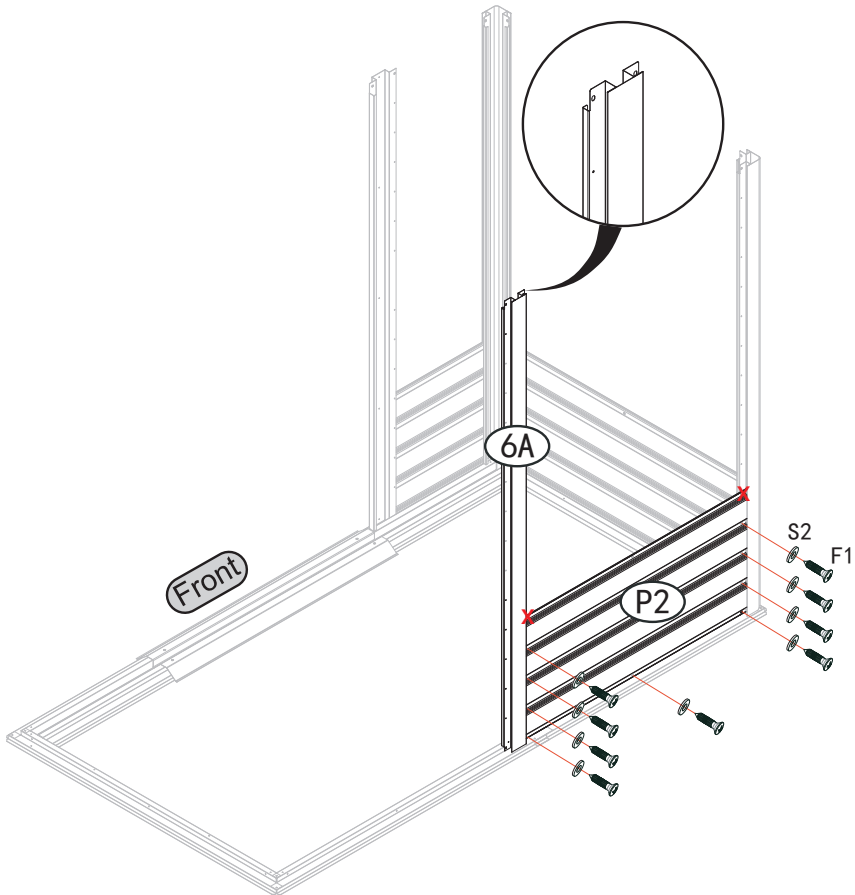
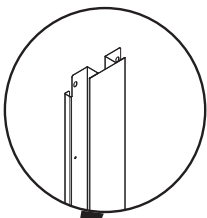

PART	NO.	Qty.
	5A	1
	P4	1
	JM5	1
	25L	1
	F1	14
	S2	9

PART	NO.	Qty.
	5A	1
	P1	1
	JM5	1
	F1	14
	S2	9







PART	NO.	Qty.
	6A	1
	P2	1
	F1	9
	S2	9

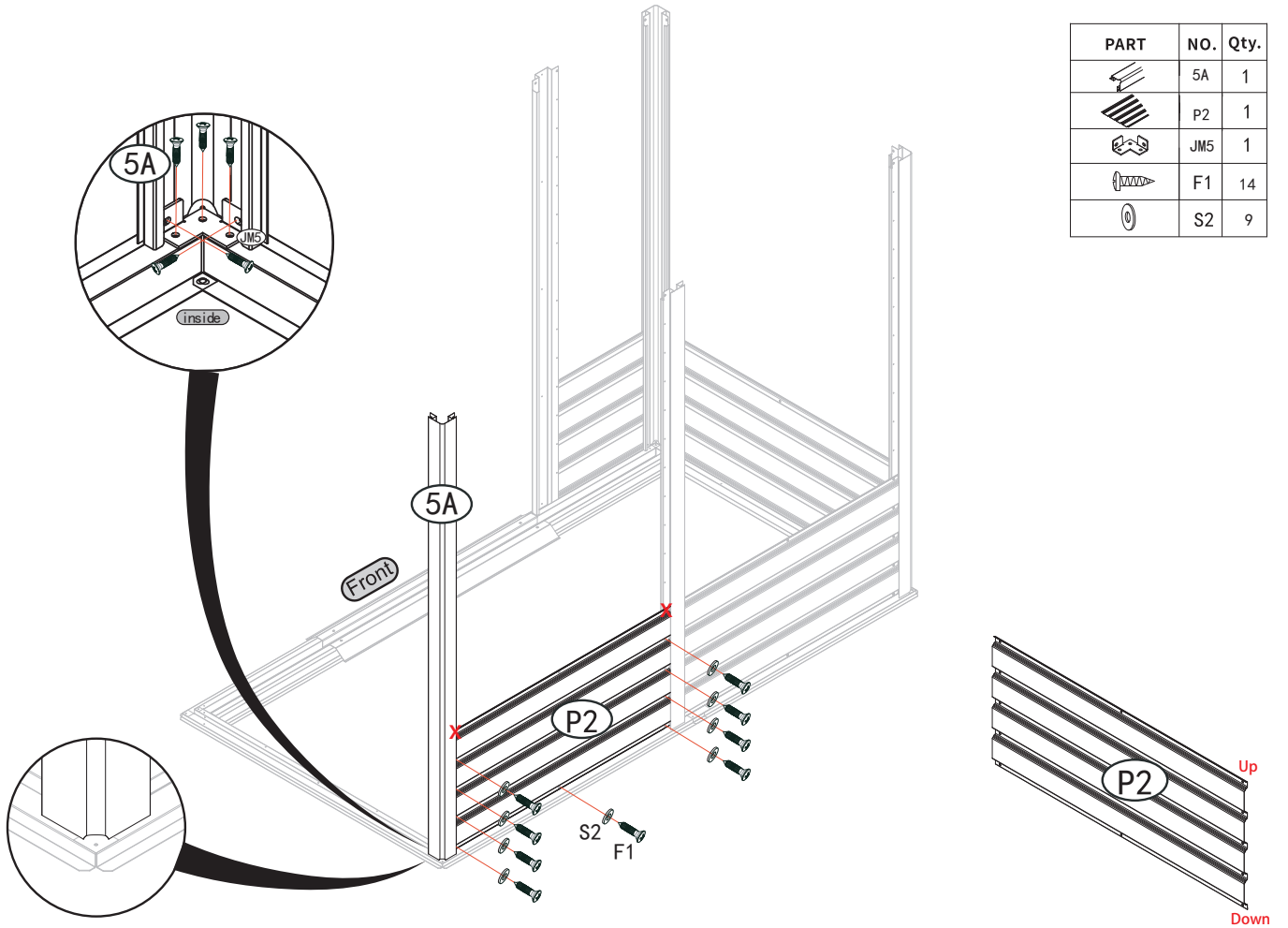

PART	NO.	Qty.
	5A	1
	P2	1
	JM5	1
	F1	14
	S2	9



PART	NO.	Qty.
	5A	1
	P1	1
	JM5	1
	F1	14
	S2	9

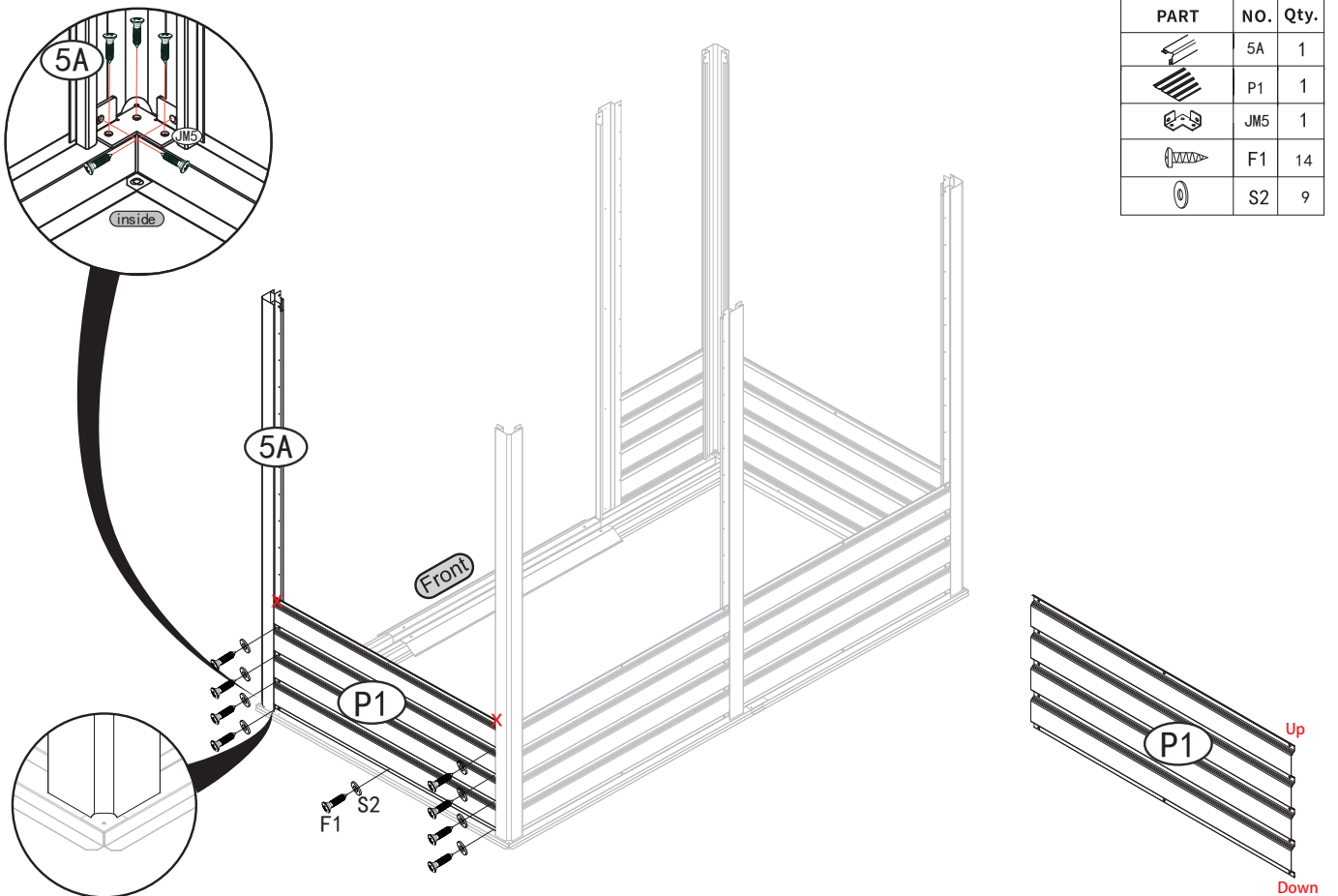

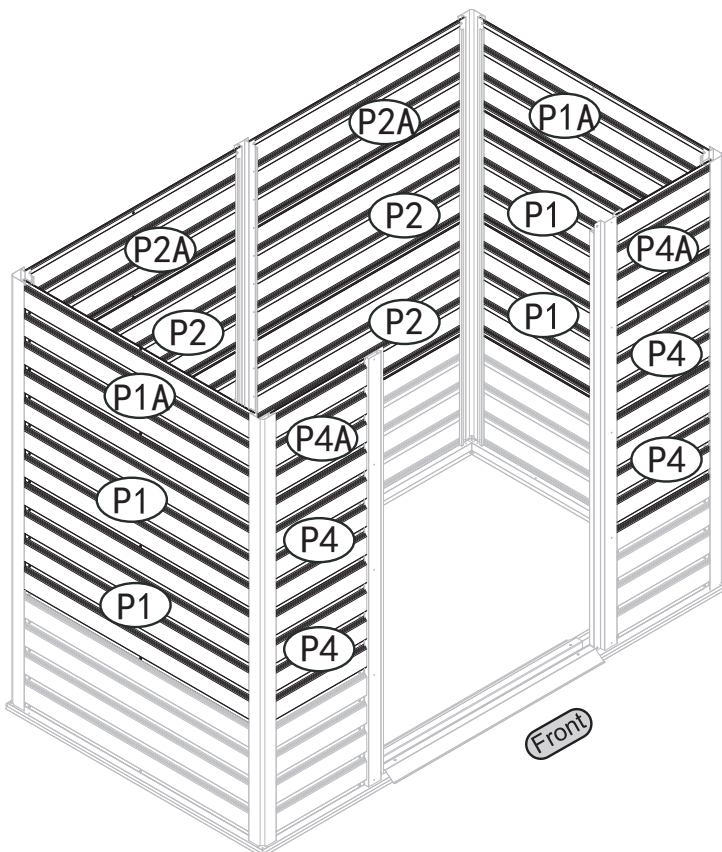
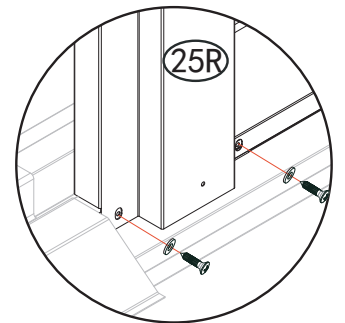
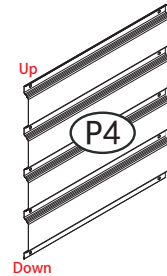
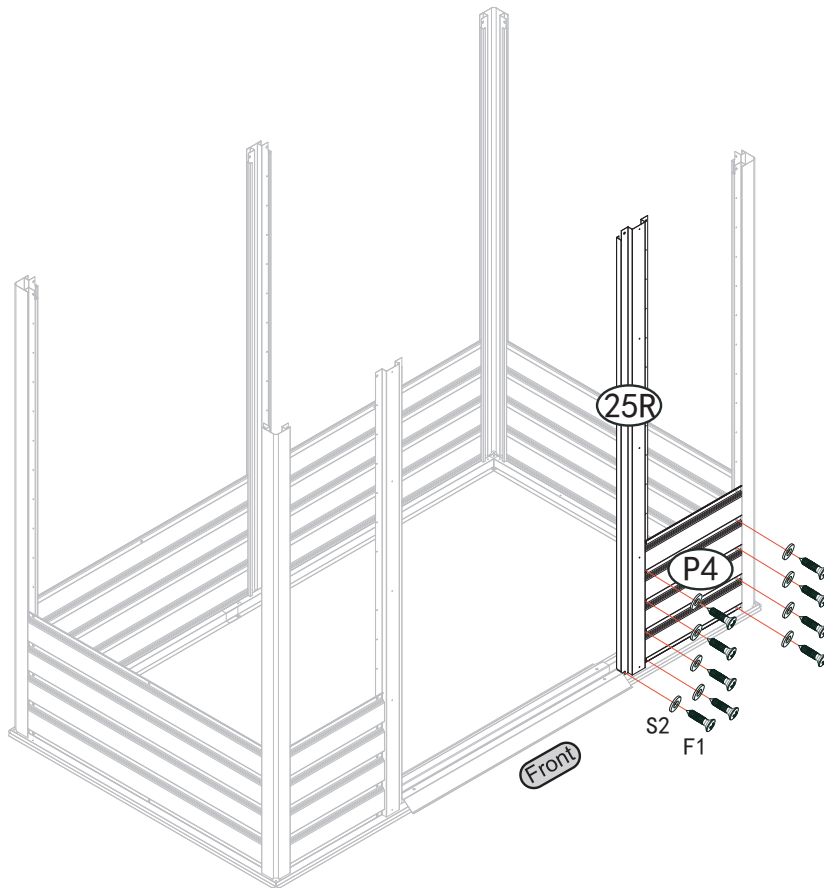

PART	NO.	Qty.
	5A	1
	P4	1
	JM5	1
	25L	1
	F1	14
	S2	9



PART	NO.	Qty.
	P1	4
	P2	4
	P4	4
	P1A	2
	P2A	2
	P4A	2



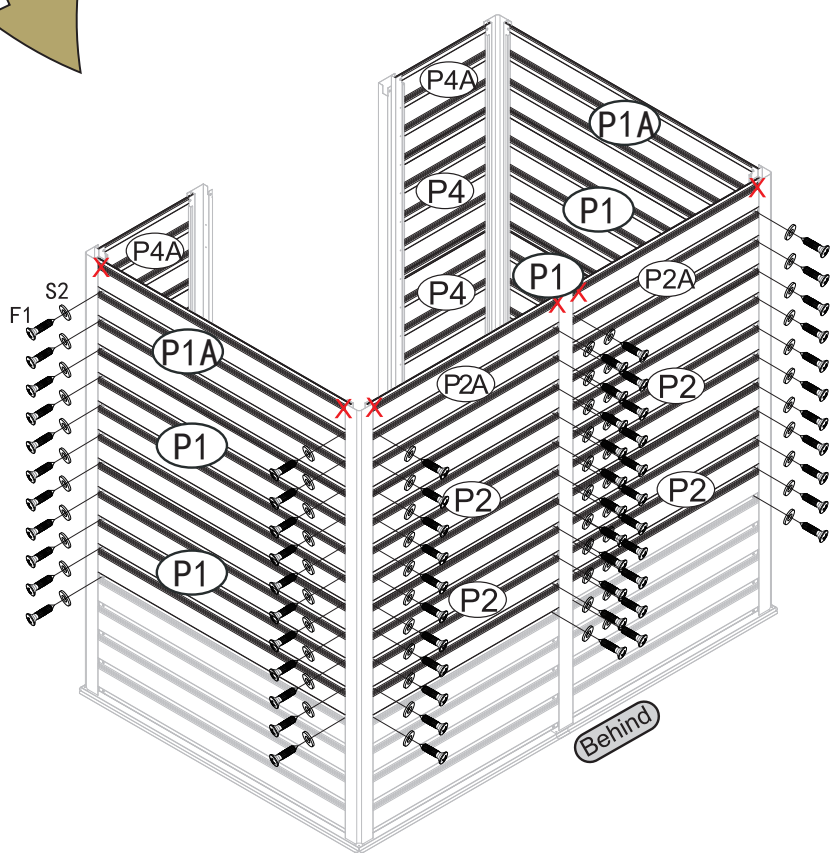
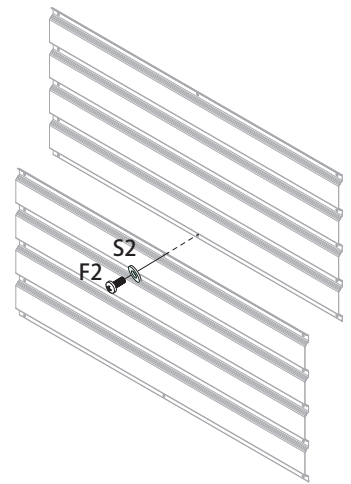
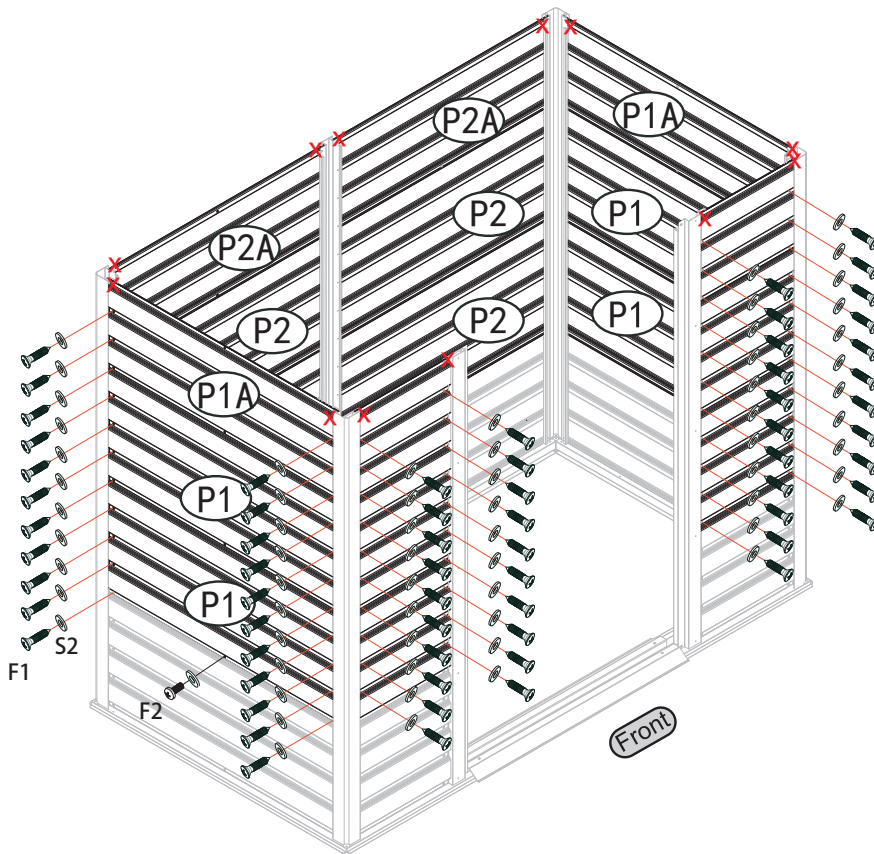

EN\_ Screw installation is shown on the next page  
FR\_ L'installation des vis est illustrée à la page suivante  
ES\_ La instalación de los tornillos se muestra en la página siguiente  
PT\_ A instalação dos parafusos é apresentada na página seguinte  
DE\_ Der Einbau der Schrauben wird auf der nächsten Seite gezeigt.  
IT\_ L'installazione delle viti è illustrata nella pagina successiva

Parts	No	Qty
	S2	150
	F1	132
	F2	18

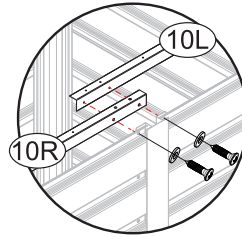
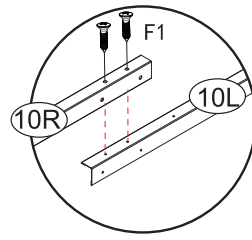
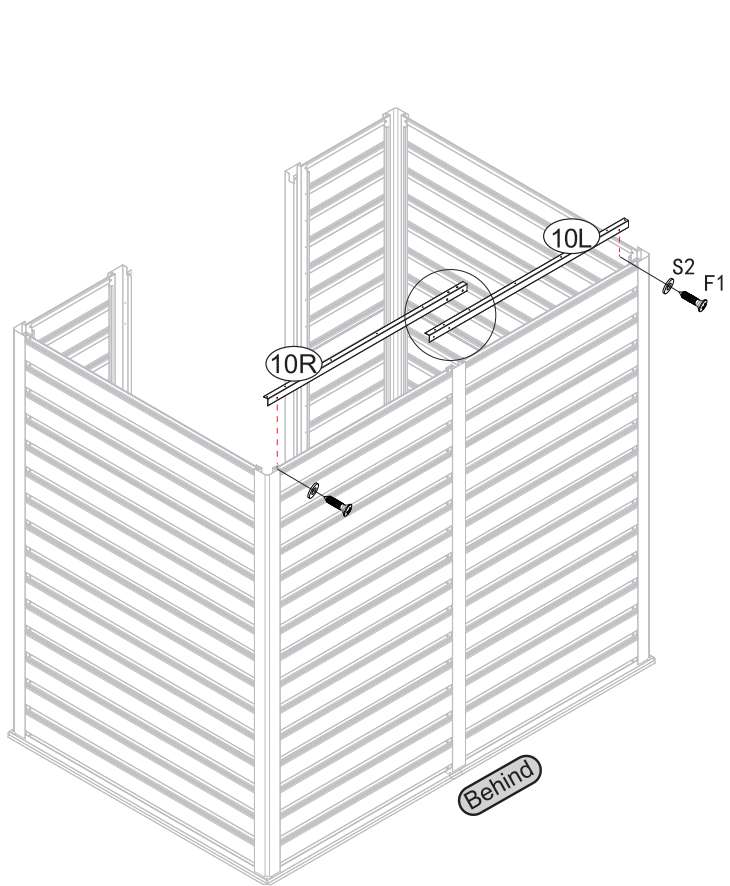



- EN\_ Add an F2 screw link between every two boards
- FR\_ Ajouter un lien à vis F2 entre deux planches
- ES\_ Añade un eslabón roscado F2 entre cada dos placas
- PT\_ Adicionar uma ligação roscada F2 entre cada duas placas
- DE\_ Hinzufügen einer F2-Schraubverbindung zwischen jeweils zwei Brettern
- IT\_ Aggiungere un collegamento a vite F2 tra ogni due schede



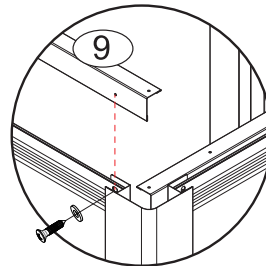
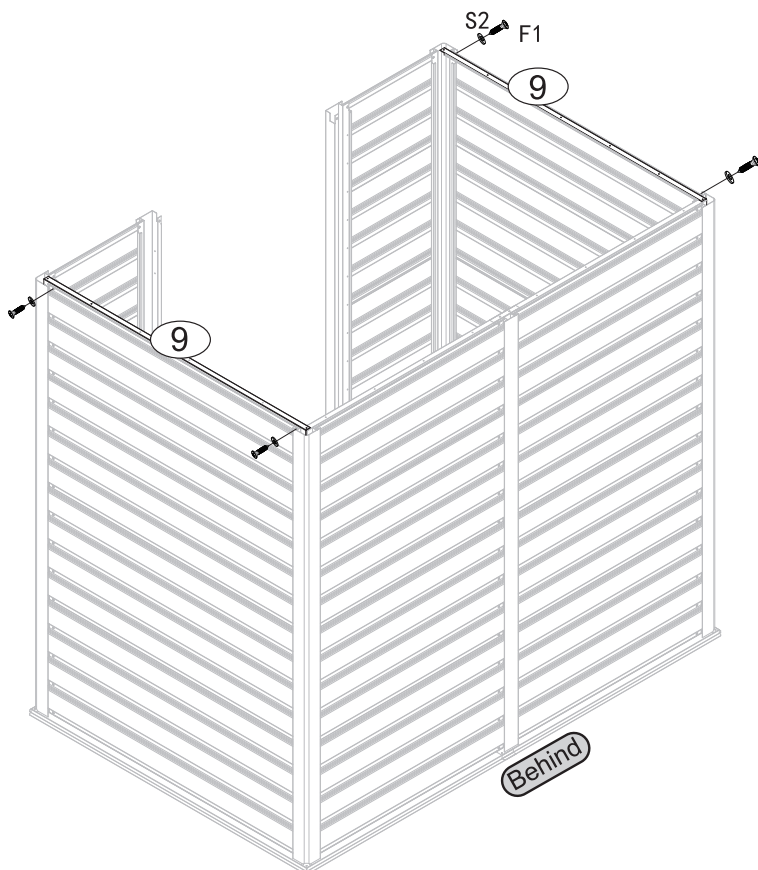



PART	NO.	Qty.
	10L	1
	10R	1
	F1	6
	S2	4

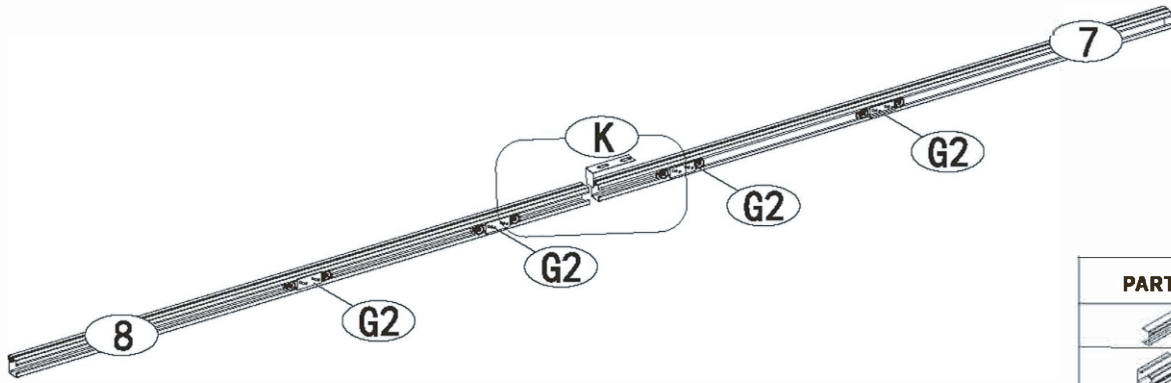
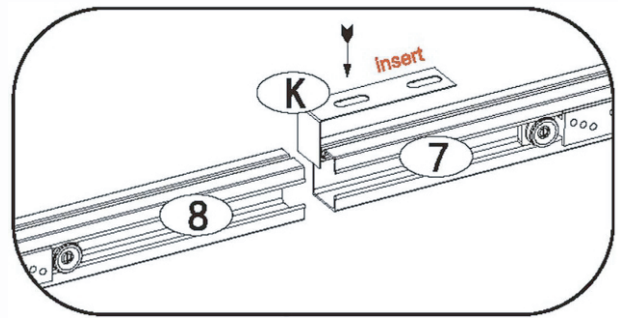
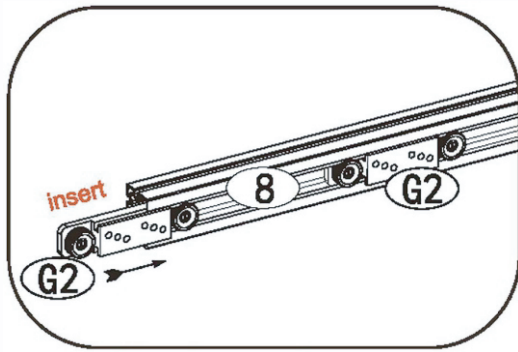



PART	NO.	Qty.
	9	2
	F1	4
	S2	4





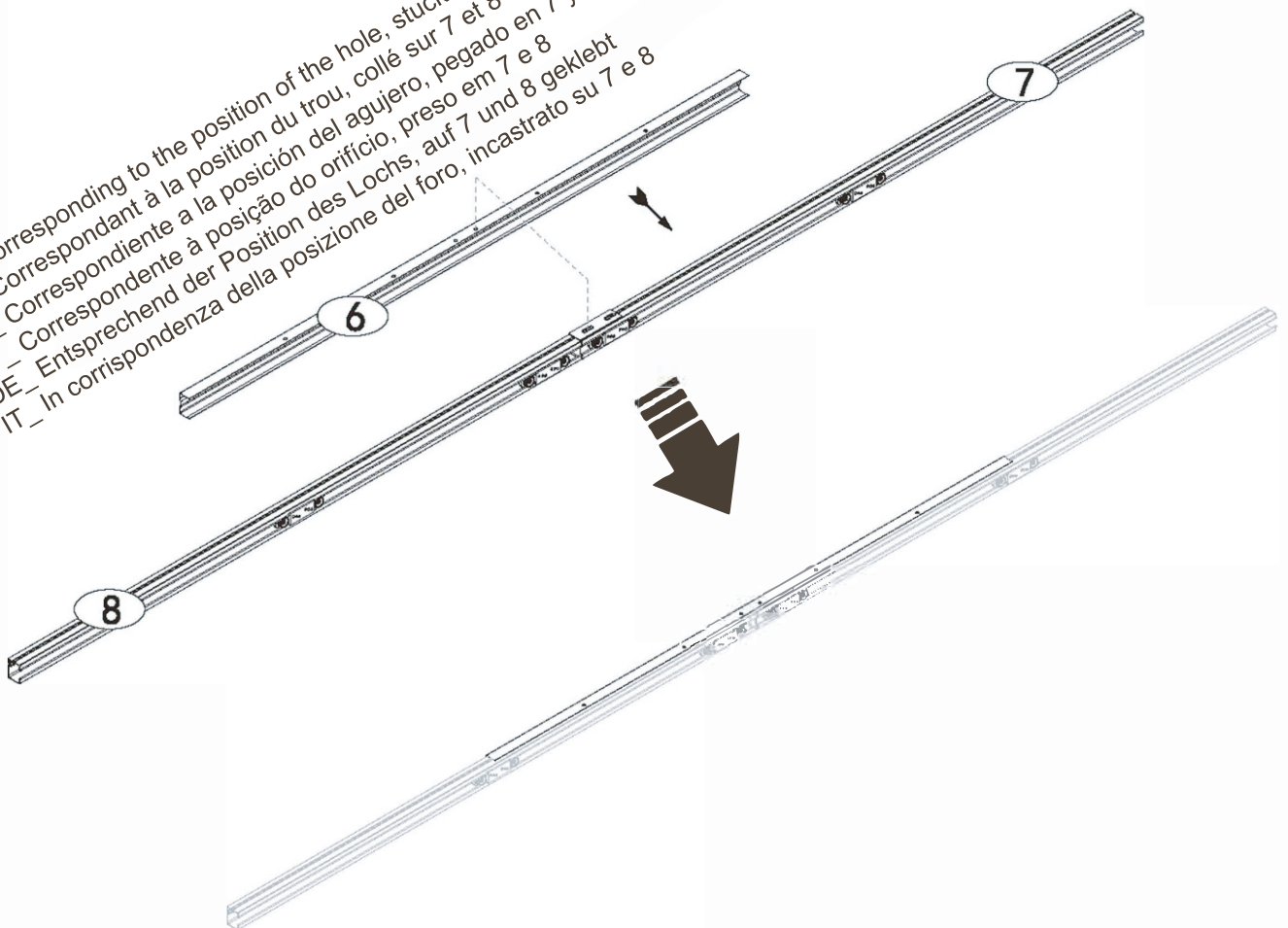

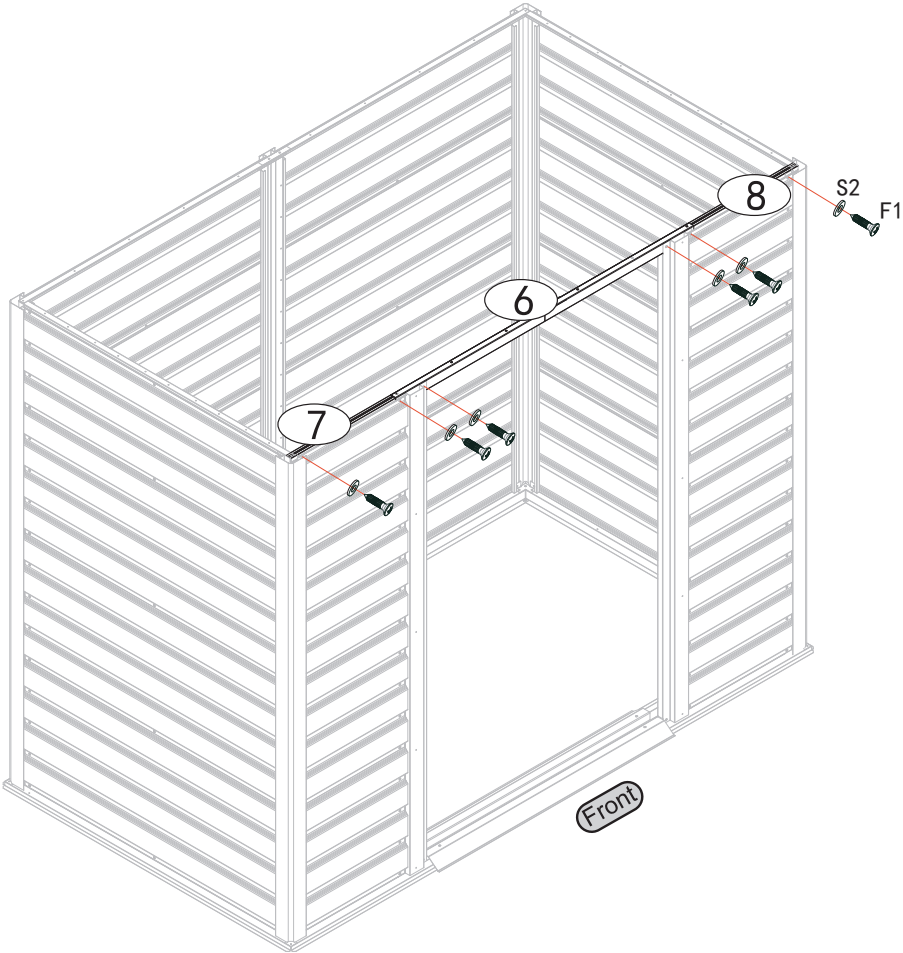
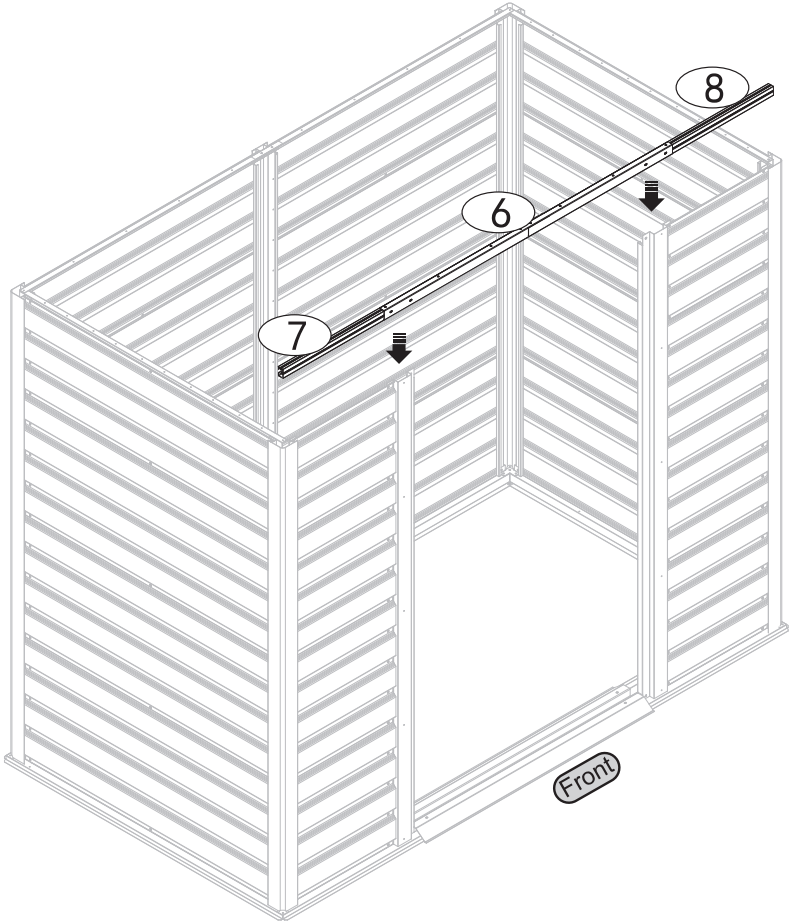

PART	NO.	Qty.
	6	1
	7	1
	8	1
	G2	4
	K	1

EN\_ Corresponding to the position of the hole, stuck on 7 and 8  
 FR\_ Correspondant à la position du trou, collé sur 7 et 8  
 ES\_ Correspondiente a la posición del agujero, pegado en 7 y 8  
 PT\_ Correspondente à posição do orifício, preso em 7 e 8  
 DE\_ Entsprechend der Position des Lochs, auf 7 und 8 geklebt  
 IT\_ In corrispondenza della posizione del foro, incastrato su 7 e 8



PART	NO.	Qty.
	F1	6
	S2	6



NO.	PART	Qty.
21L		2
21R		2
B1		2
GF		4
F2		12
S2		12

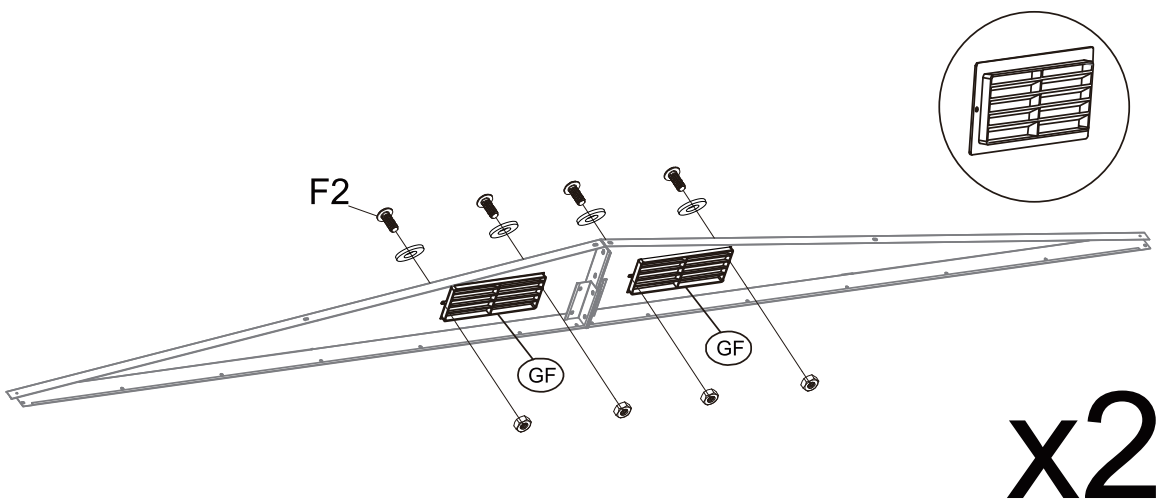
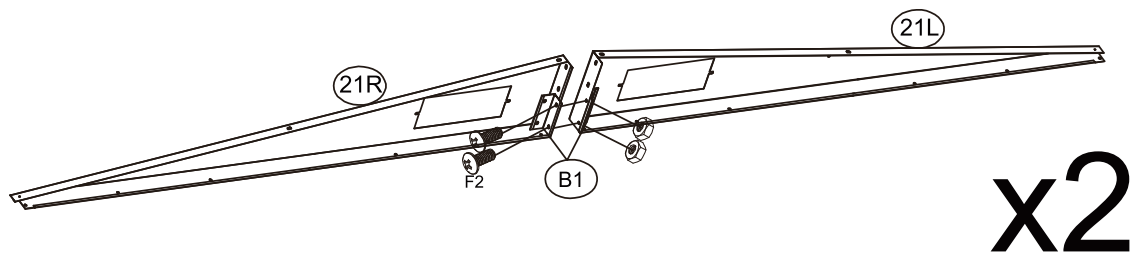

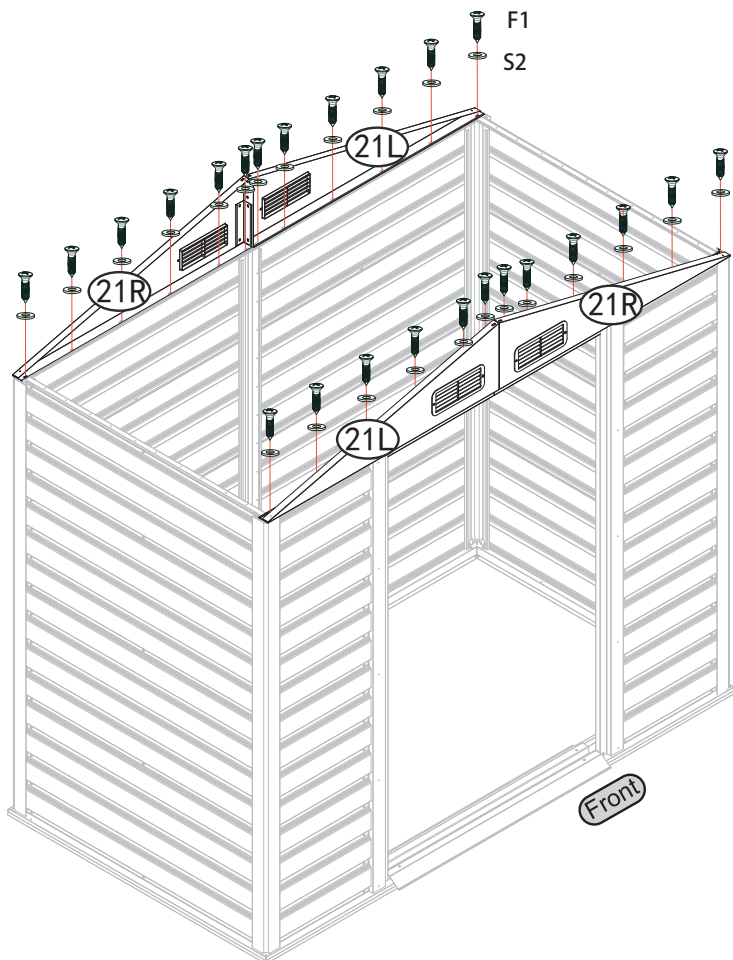

NO.	PART	Qty.
F1		24
S2		24

EN\_ Don't tighten these two screws too tightly  
 FR\_ Ne serrez pas ces deux vis trop fort  
 ES\_ No apriete demasiado estos dos tornillos  
 PT\_ Não apertar demasiado estes dois parafusos  
 DE\_ Ziehen Sie diese beiden Schrauben nicht zu fest an.  
 IT\_ Non stringere troppo le due viti

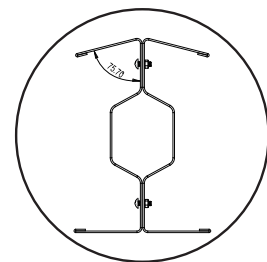
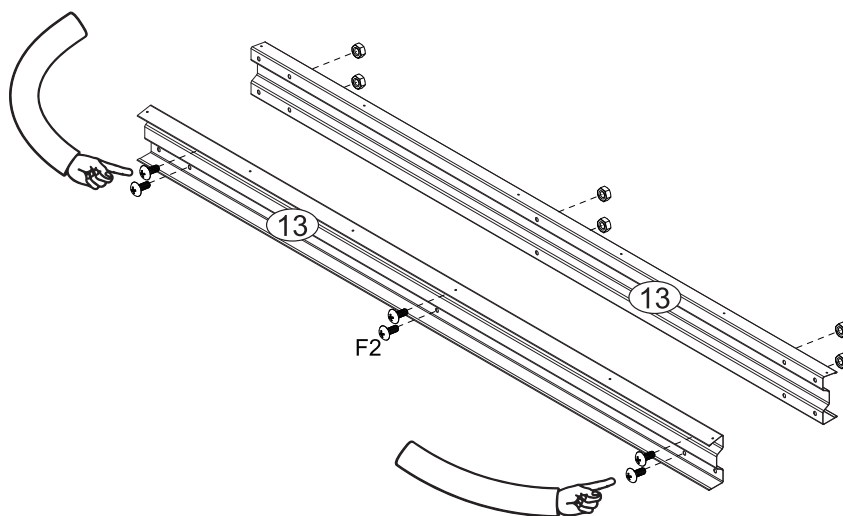

EN\_ Don't tighten these two screws too tightly  
 FR\_ Ne serrez pas ces deux vis trop fort  
 ES\_ No apriete demasiado estos dos tornillos  
 PT\_ Não apertar demasiado estes dois parafusos  
 DE\_ Ziehen Sie diese beiden Schrauben nicht zu fest an.  
 IT\_ Non stringere troppo le due viti

NO.	PART	Qty.
13		2
F2		6

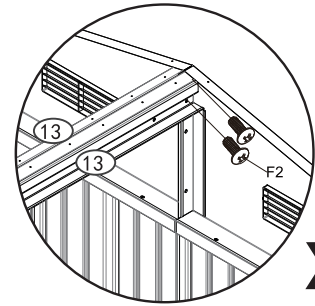
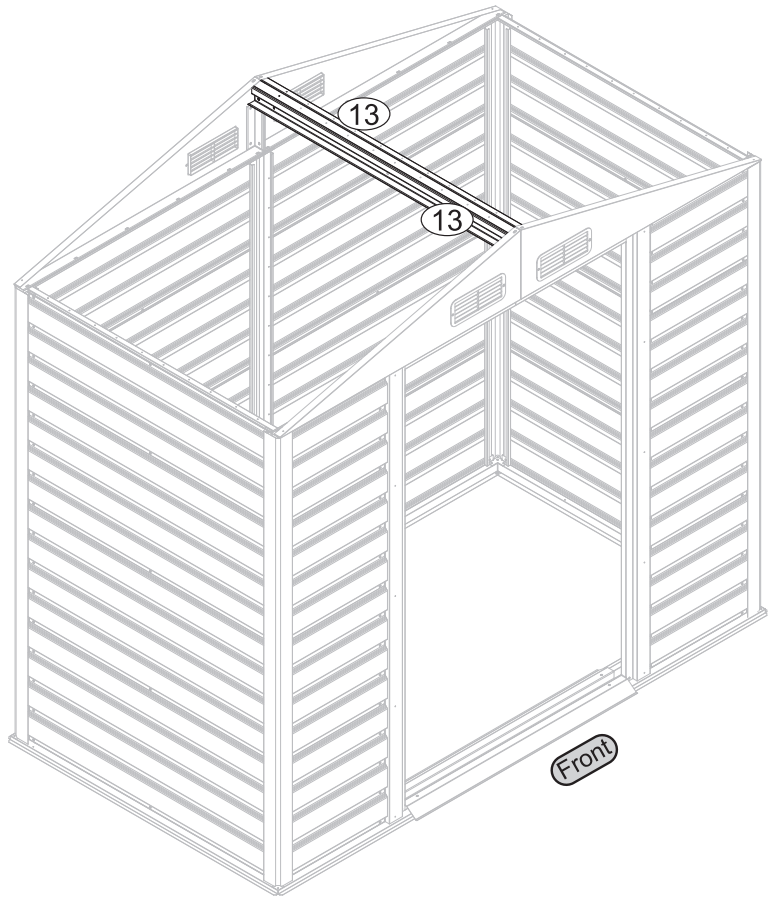

x2

NO.	PART	Qty.
13		2
F2		4

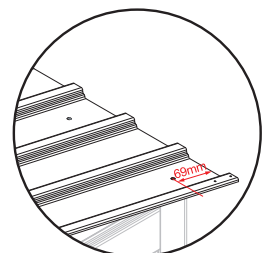
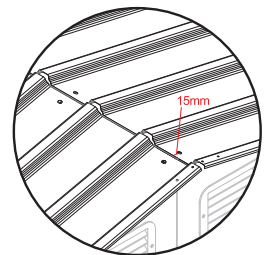
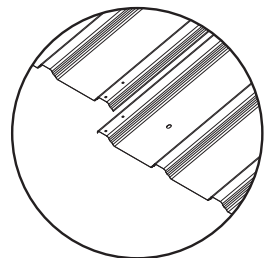
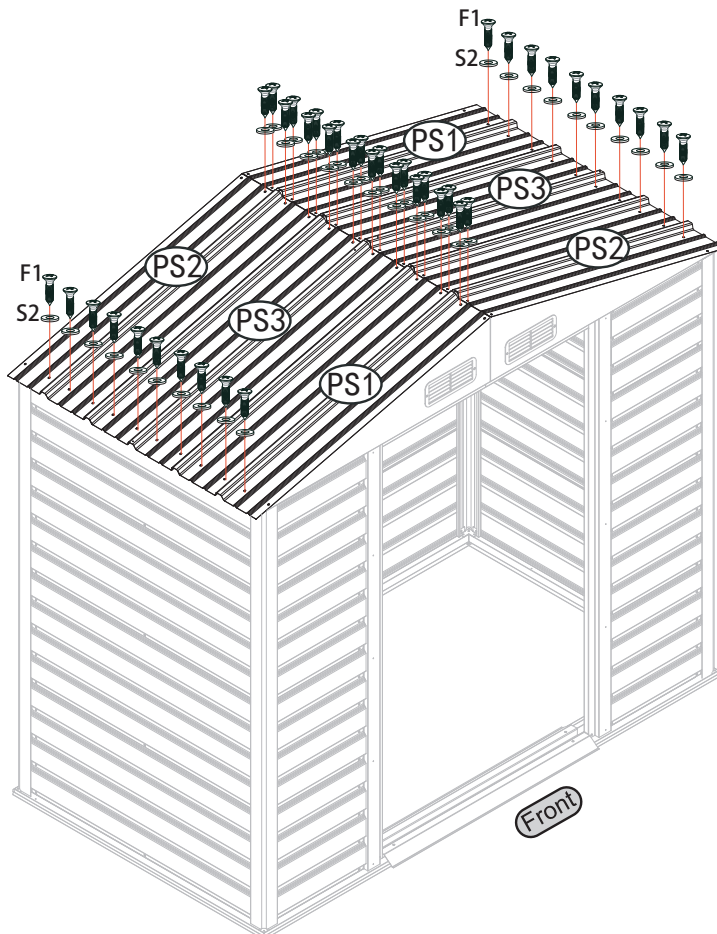

PART	NO.	Qty.
	PS1	2
	PS2	2
	PS3	2
	F1	40
	S2	40

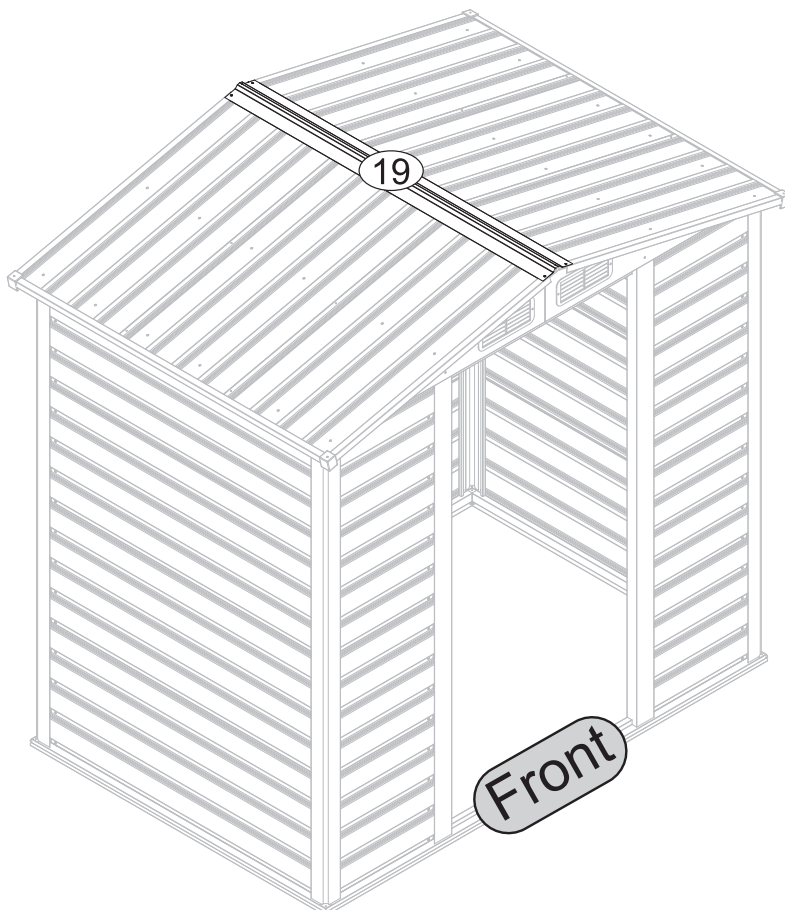
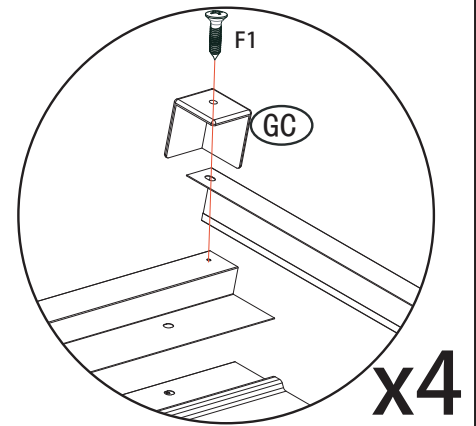
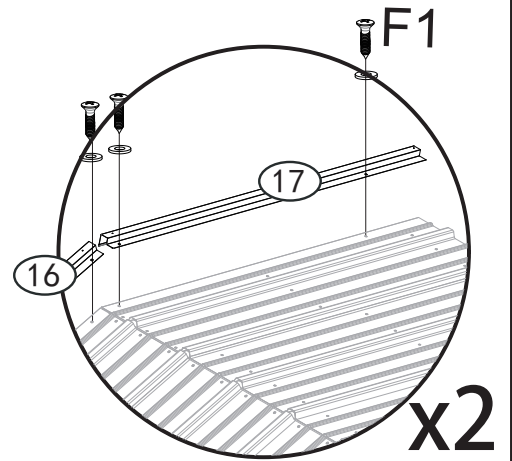
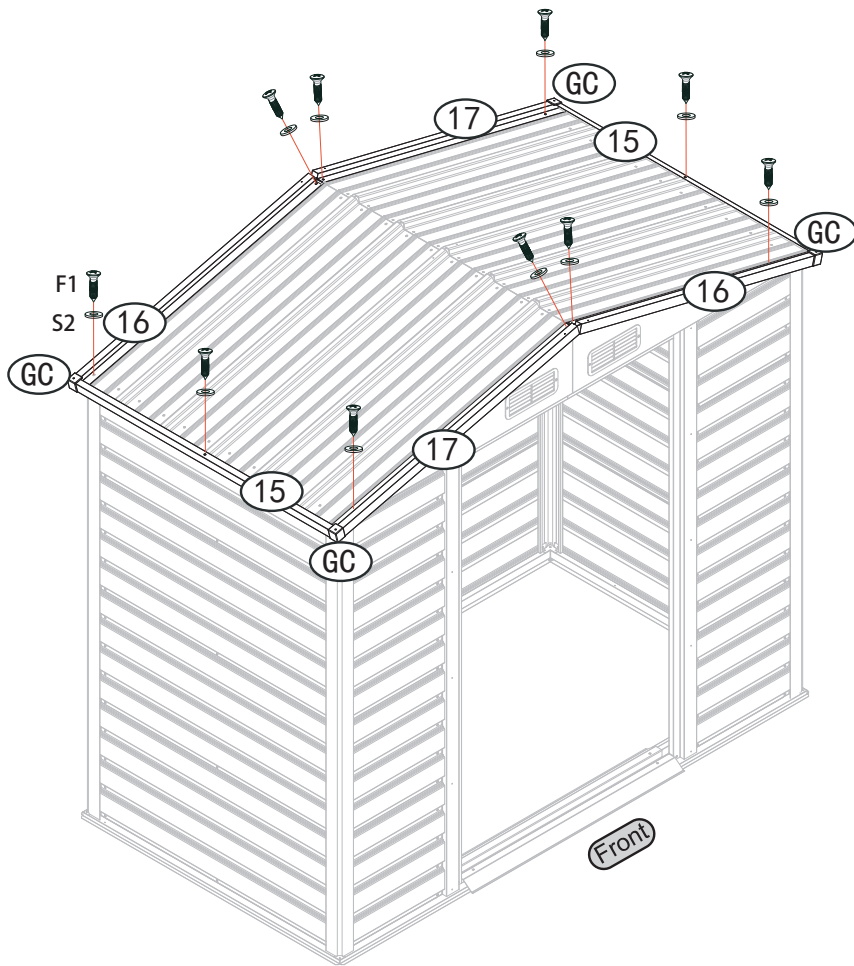

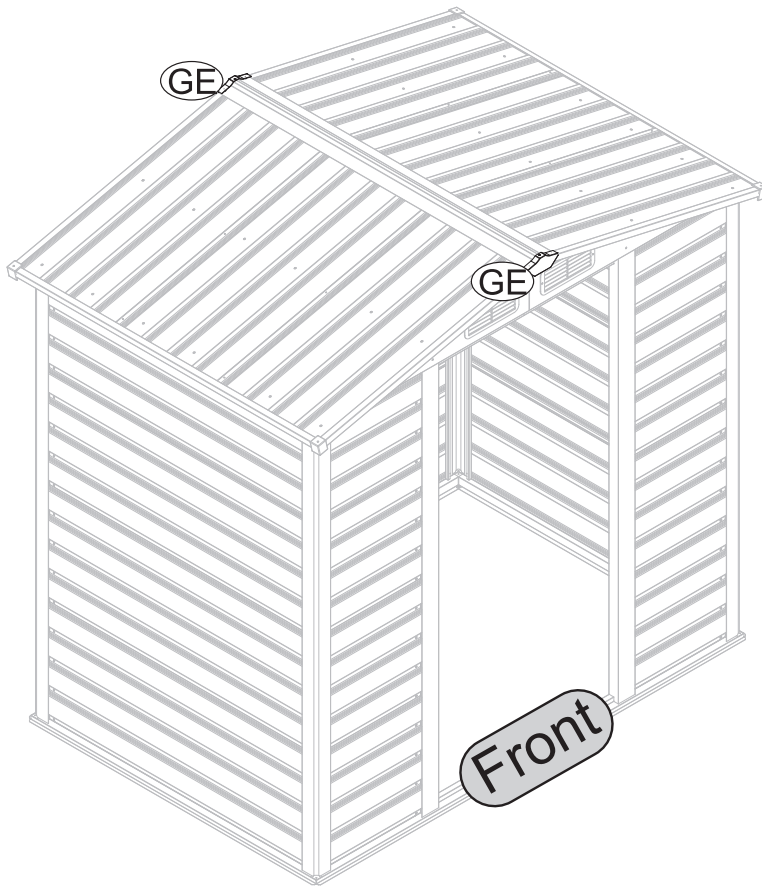

PART	NO.	Qty.
	15	2
	16	2
	17	2
	19	1
	GC	2
	F1	14
	S2	14





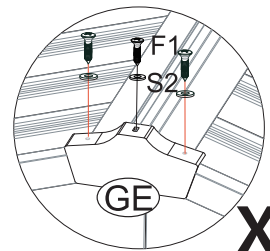
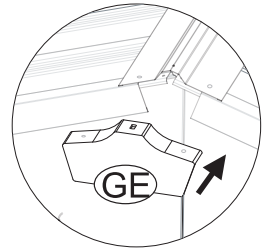

PART	NO.	Qty.
	GE	2
	F1	2
	S2	2

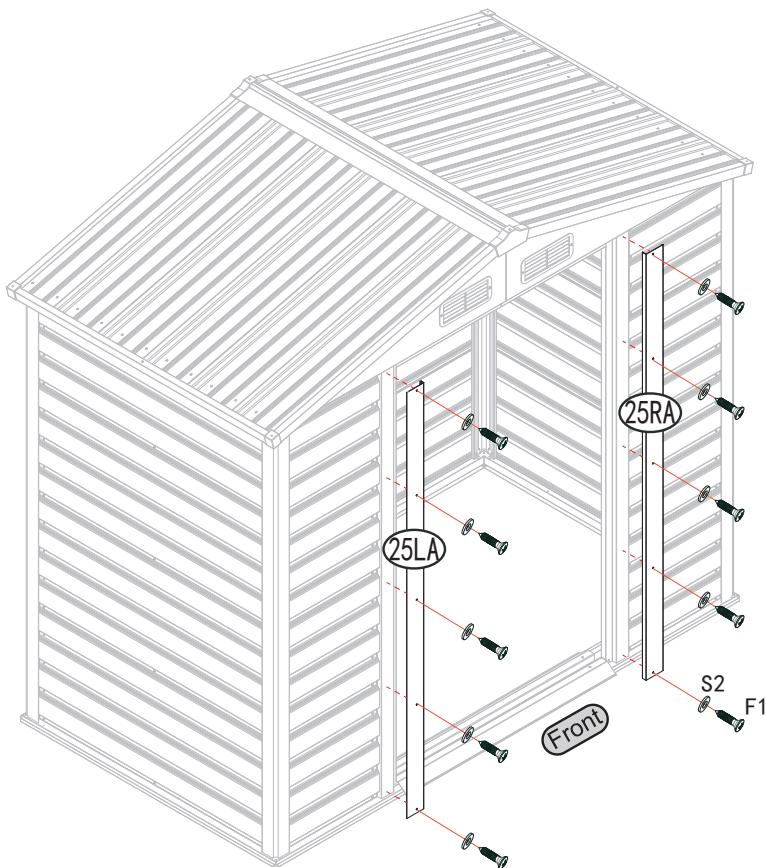

x2





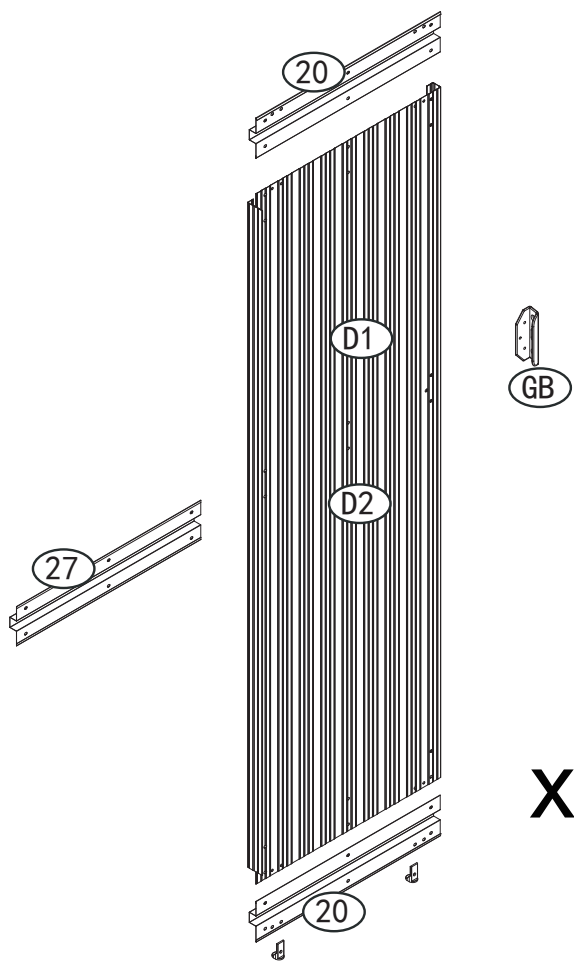



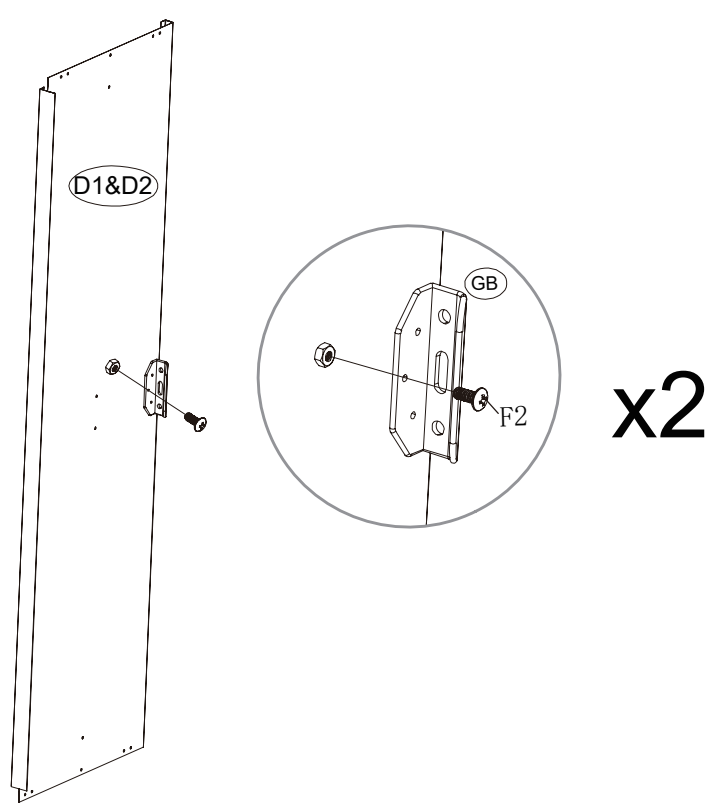



PART	NO.	Qty.
	25LA	1
	25RA	1
	F1	10
	S2	10





EN\_ D1 and D2 have the same installation steps  
 FR\_ D1 et D2 ont les mêmes étapes d'installation  
 ES\_ D1 y D2 tienen los mismos pasos de instalación  
 PT\_ D1 e D2 têm os mesmos passos de instalação  
 DE\_ D1 und D2 haben die gleichen Installationsschritte  
 IT\_ D1 e D2 hanno le stesse fasi di installazione



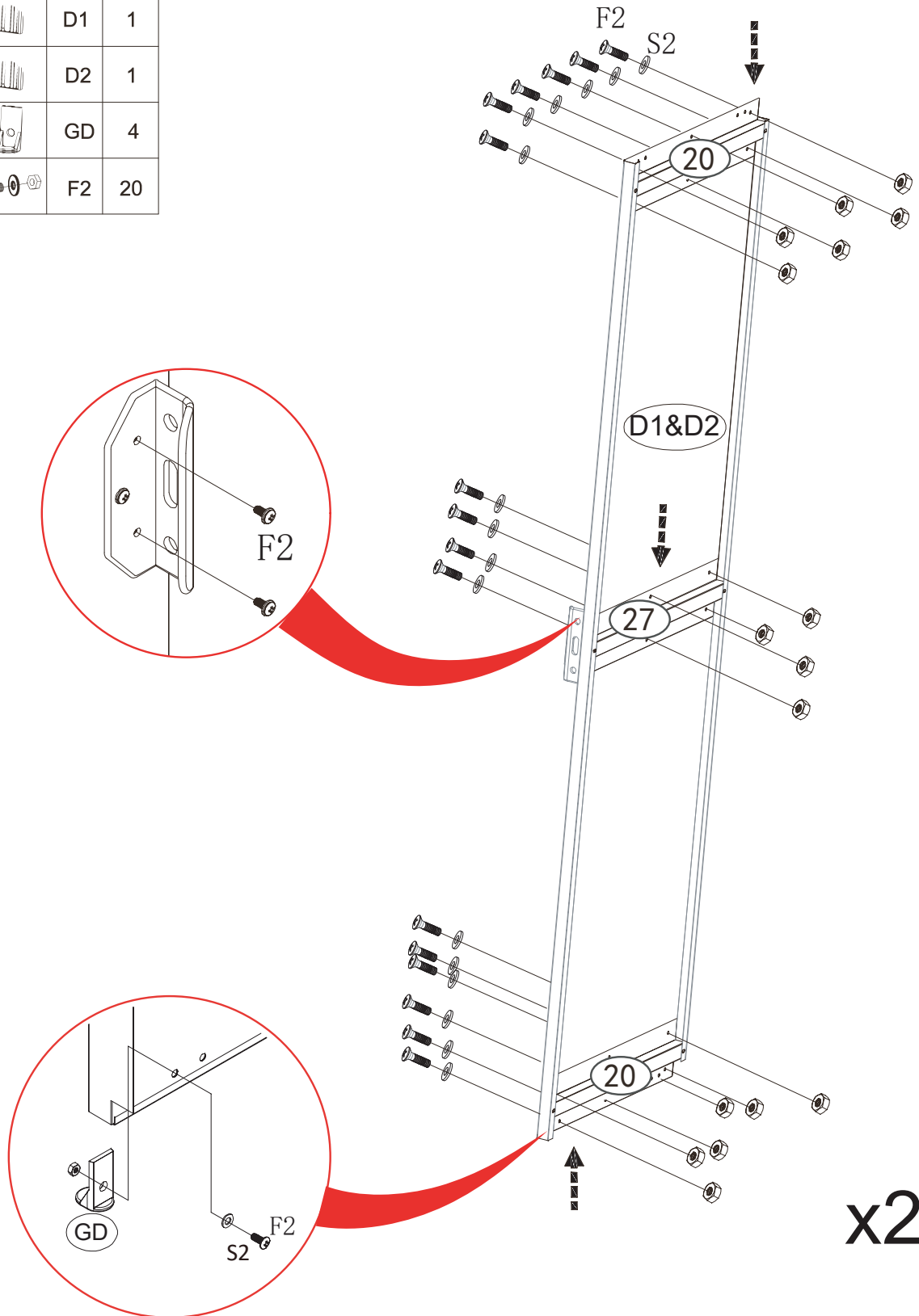

PART	NO.	Qty.
	D1	1
	D2	1
	GB	2
	F2	2

PART	NO.	Qty.
	27	2
	20	4
	GB	2
	D1	1
	D2	1
	GD	4
	F2	20

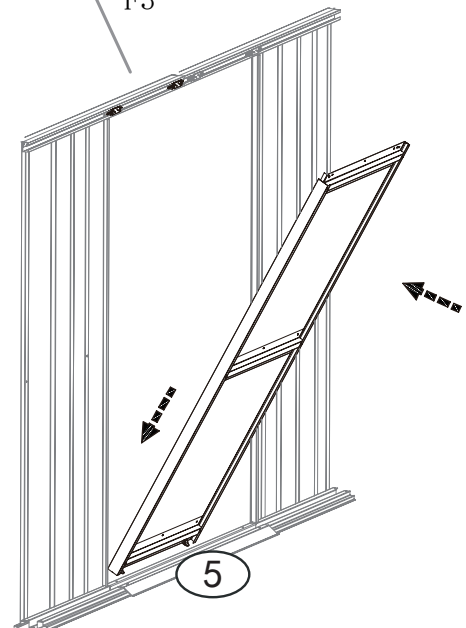
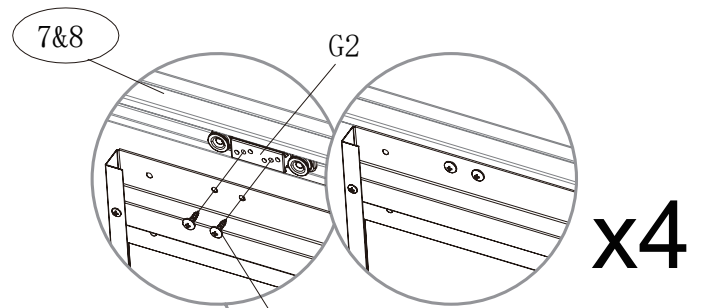
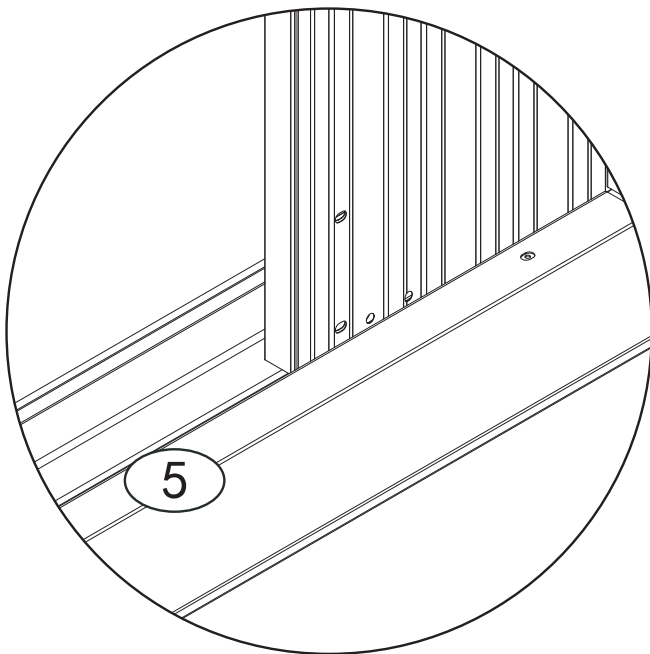
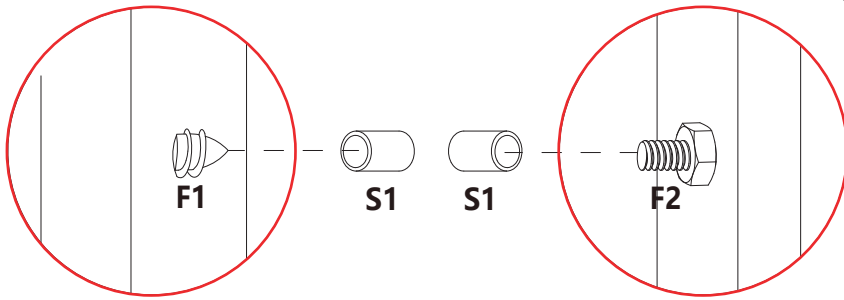
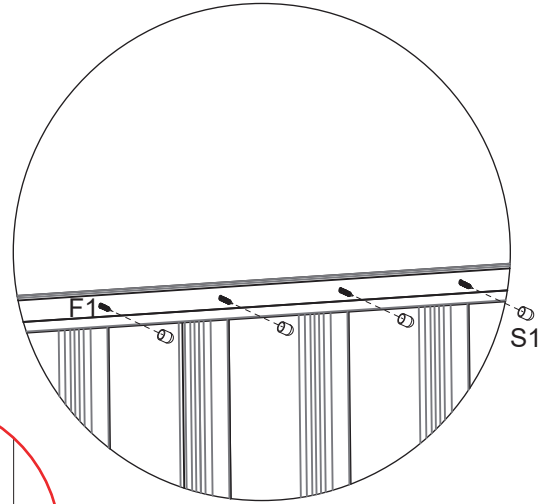

NO.	PART	Qty.
S1		329



PART	NO.	Qty.
	F3	8

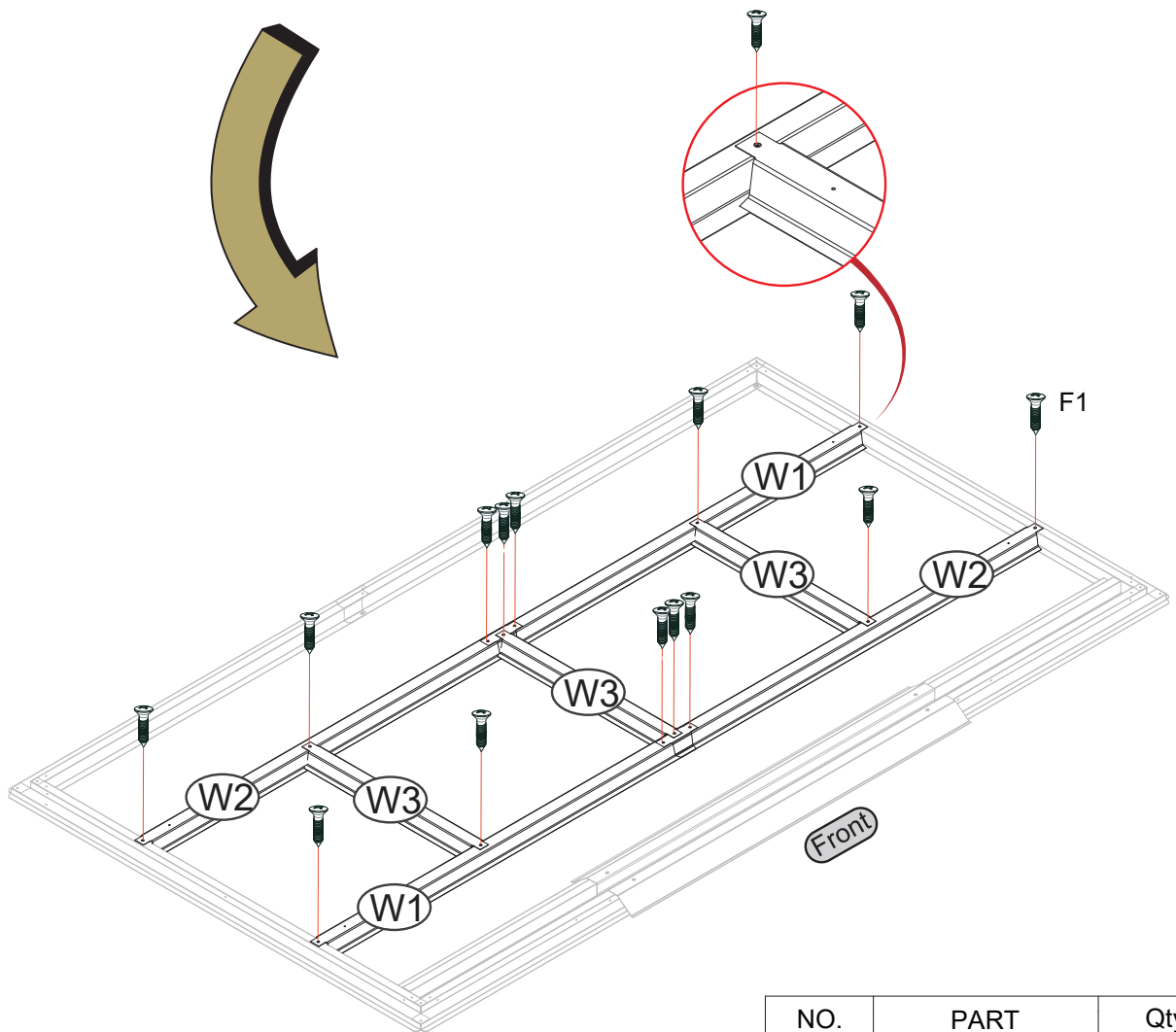
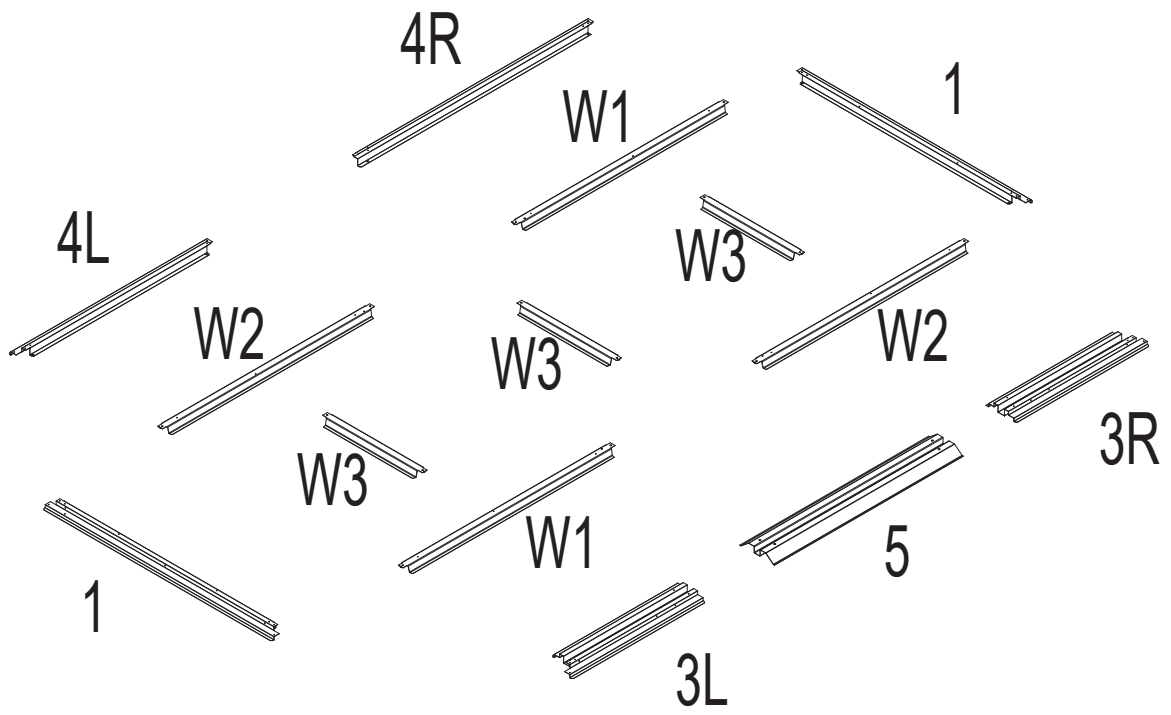

NO.	PART	Qty.
F1		12

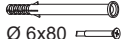
	No#:	Quantity
	F6	4

