

ASSEMBLY INSTRUCTIONS

MODEL : DINING CHAIR

IMPORTANT NOTE :

- * PLACE ALL WOODEN PARTS ON A CLEAN AND SMOOTH SURFACE SUCH AS A RUG OR CARPET TO AVOID THE PARTS FROM BEING SCRATCHED.
- * BEFORE YOU BEGIN, KINDLY FOLLOW THE ASSEMBLY INSTRUCTIONS STEP BY STEP.
- * DO NOT TIGHTEN ALL SCREWS UNTIL THE CHAIR IS FULLY SET-UP.

HARDWARE LIST		PART LIST	
A	JCBC M6 x 25mm + S/W M6 + F/W M6 x 13mm 4PCS	1	RIGHT SIDE FRAME 1PC
B	JCBC M6 x 45mm + S/W M6 + F/W M6 x 13mm 4PCS	2	LEFT SIDE FRAME 1PC
C	ALLEN KEY M4 1PC	3	FRONT STRETCHER 1PC
D	L BRACKET 4PCS	4	BACK STRETCHER 1PC
E	PH SCREW M4 x 12mm 8PCS	5	TOP REST 1PC
F	WOOD DOWEL M8 x 25mm 2PCS	6	CUSHION SEAT 1PC

CAUTIONS :

(1) DO NOT FULLY-TIGHTEN THE NUT OR NUT BOLTS INITIALLY UNTIL ALL NUTS OR BOLT IS READY ASSEMBLED.

(TO AVOID CAUSING DAMAGES TO THE THREAD, DO NOT OVER-TIGHTEN THE NUTS OR BOLTS.)

(2) KEEP ALL HARDWARE PART OUT OF REACH OF CHILDREN.

STEP 1

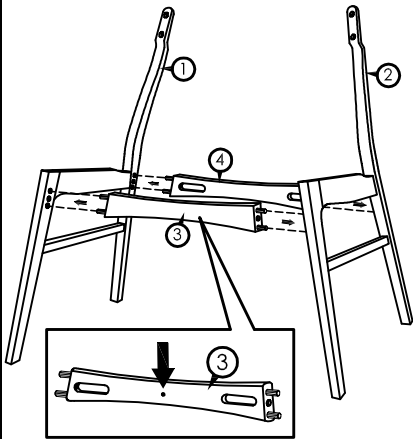

Front Stretcher has a small hole for identification.

STEP 2

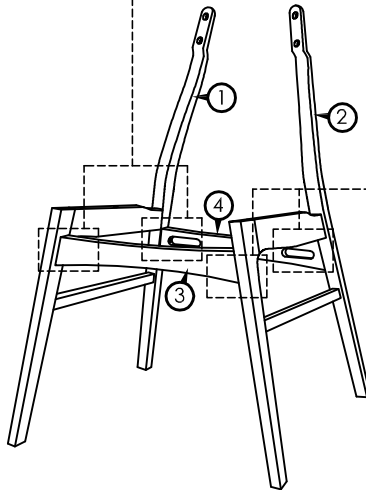
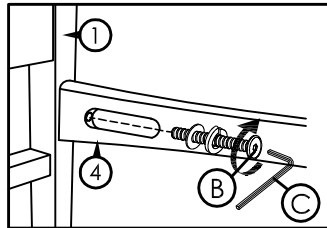

STEP 3

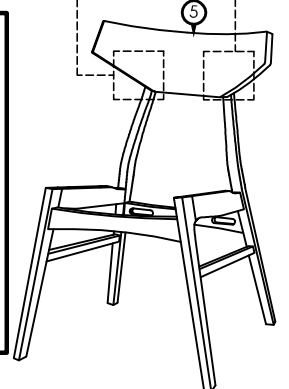
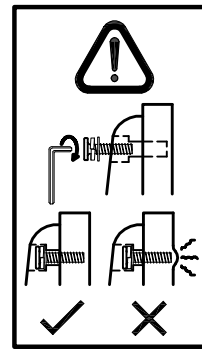
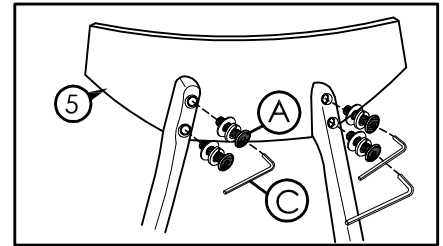

STEP 4

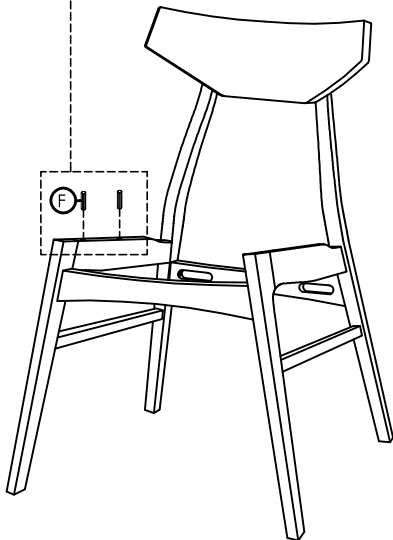
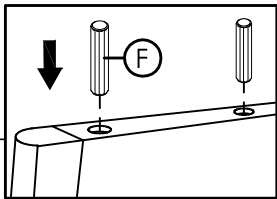

STEP 5

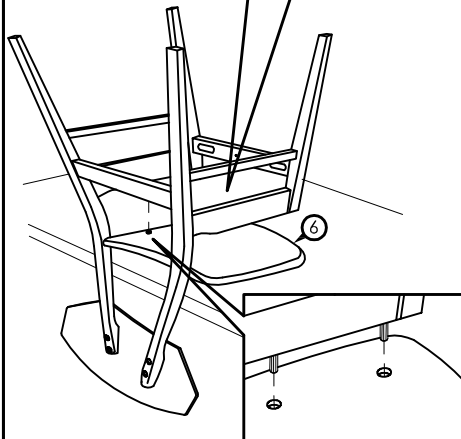
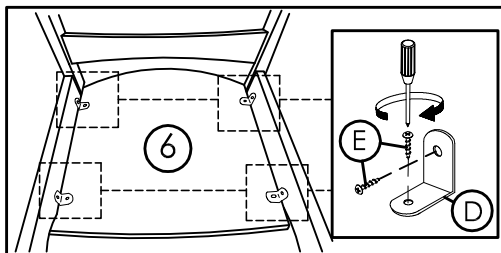

STEP 6

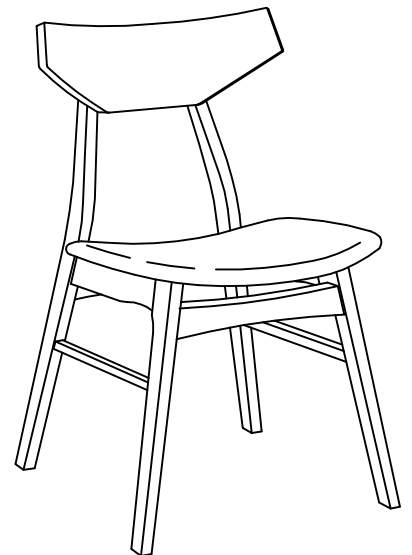



COMPLETED
CHAIR ASSEMBLY.

ASSEMBLY INSTRUCTIONS

MODEL : FIESTA RECTANGLE DINING TABLE

IMPORTANT NOTE :

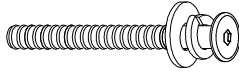
- * PLACE ALL WOODEN PARTS ON A CLEAN AND SMOOTH SURFACE SUCH AS A RUG OR CARPET TO AVOID THE PARTS FROM BEING SCRATCHED.
- * BEFORE YOU BEGIN, KINDLY FOLLOW THE ASSEMBLY INSTRUCTIONS STEP BY STEP.

HARDWARE LIST		
A	JCBB M8 x 80mm + S/W 5/16" + F/W 5/16" x 22mm 	8PCS
B	ALLEN KEY M5 	1PC

PART LIST		
1	TABLE TOP	1PC
2	TABLE LEG	4PCS

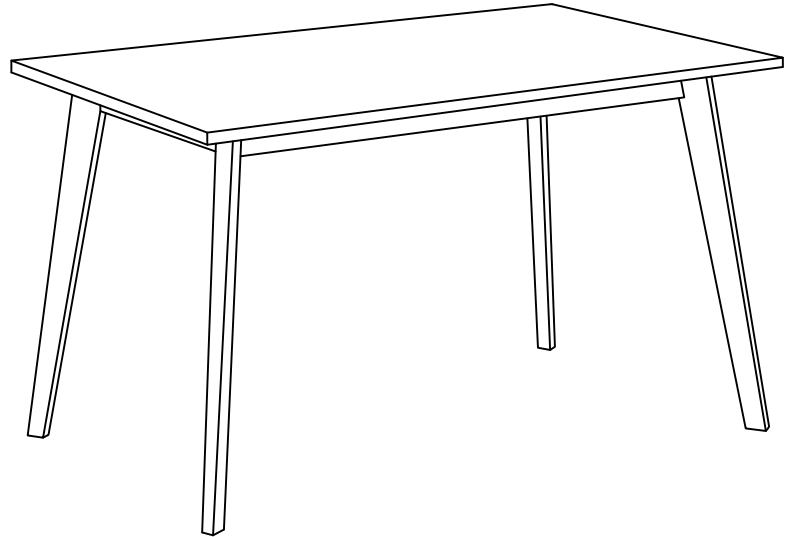

COMPLETED TABLE ASSEMBLY.

