

Assembly Instructions

⚠ Before you throw the carton, please ensure that you have all the parts needed for the assembly.

⚠ **Hardware Note:**
1. For each step please don't fully tighten all the screws at first, when they all align with the holes you can fully tighten them.
2. All the bolts should be assembled **vertically** to the holes.

⚠ **Spare parts can be found in the hardware box** if you do not have enough bolts for assembly.

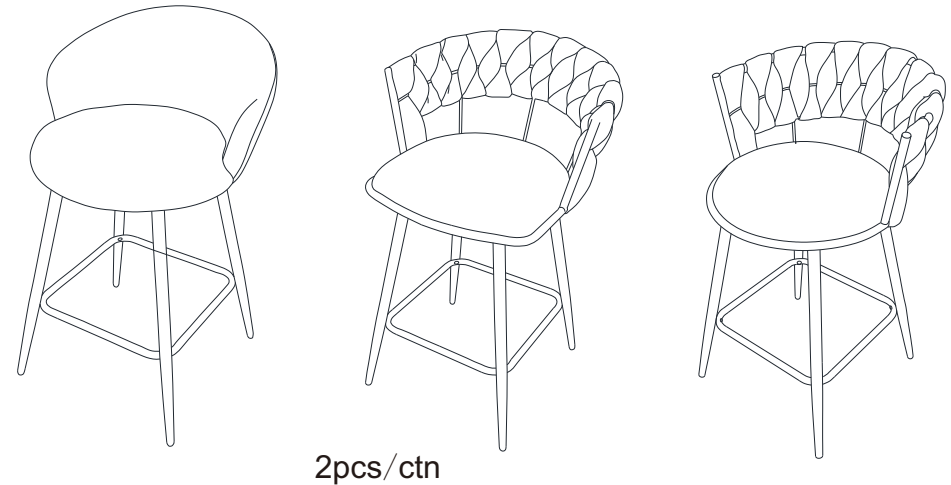





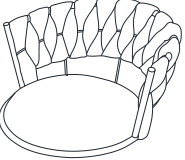

⚠ THIS INSTRUCTION BOOKLET CONTAINS IMPORTANT SAFETY INFORMATION. PLEASE READ AND KEEP FOR FUTURE REFERENCE.

Assembly Instructions

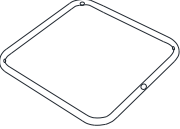
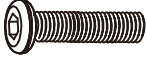
Parts and Hardware

Please check to make sure you have all parts and hardware before starting assembly process

A  x2	B  x8	C  x2	1  x8	2  assembled on part A x24	3  x1	4  x24	5  x24
---	---	---	--	---	---	--	--

Assembly Instructions

Do not tighten any single bolt until all bolts are assembled.

Remove 24 bolts from the bottom of part A

